

METAL EARTH™

3D LASER CUT MODELS

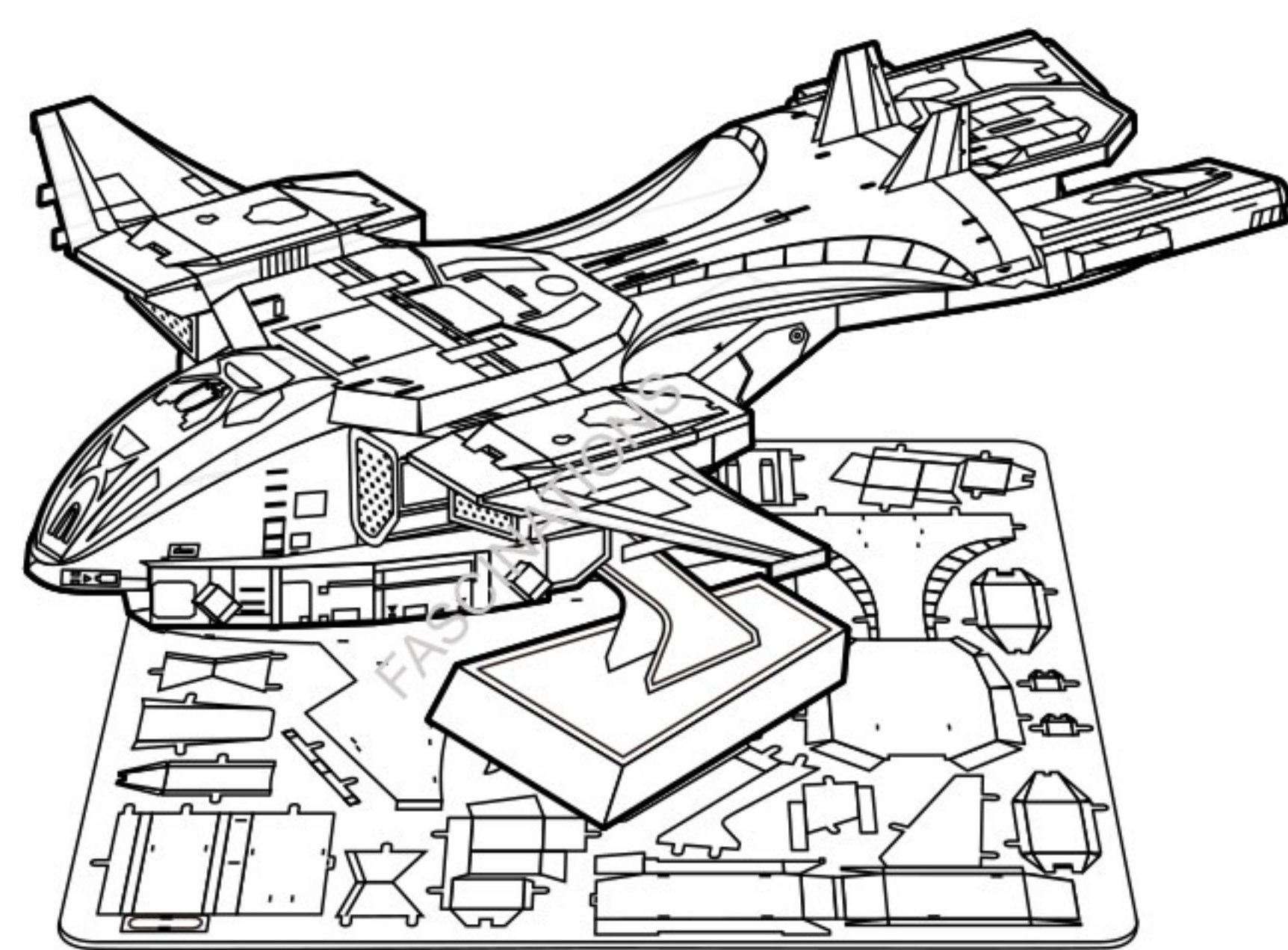

It is highly recommended that you visit www.fascinations.com/metalearth360/mms292 to see the completed model before assembling your own



mms292

To create the best connections

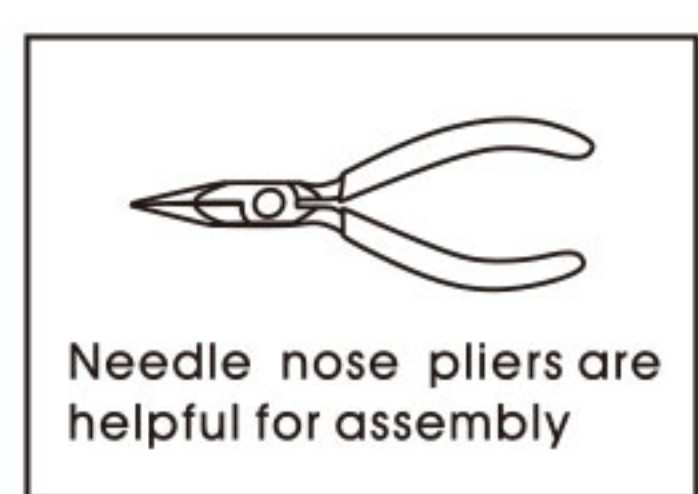
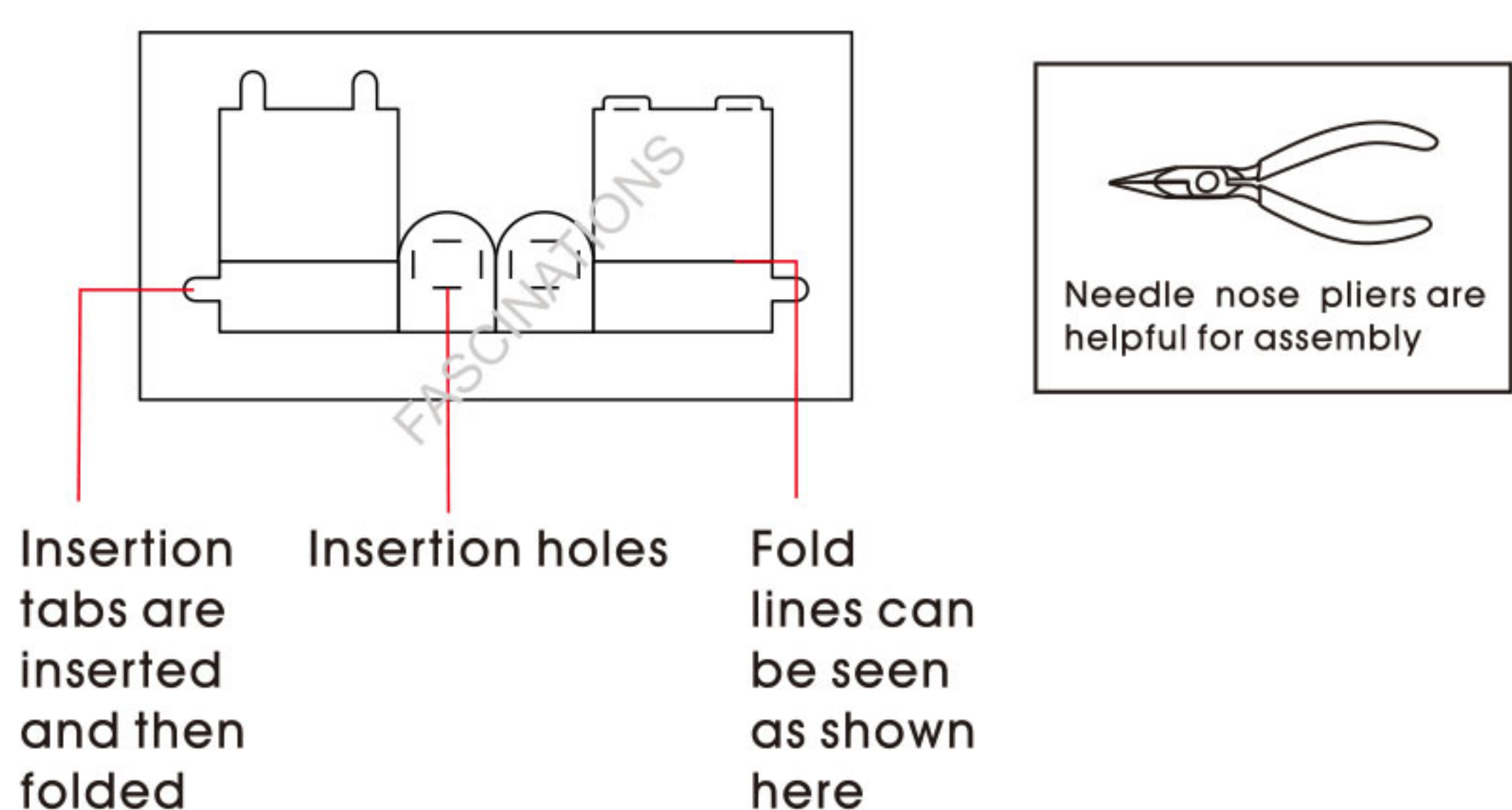

- Insert tab and bend 90 for most visible areas
- ▲ Insert tab and twist 90 degrees is best in some areas to ensure a tight connection

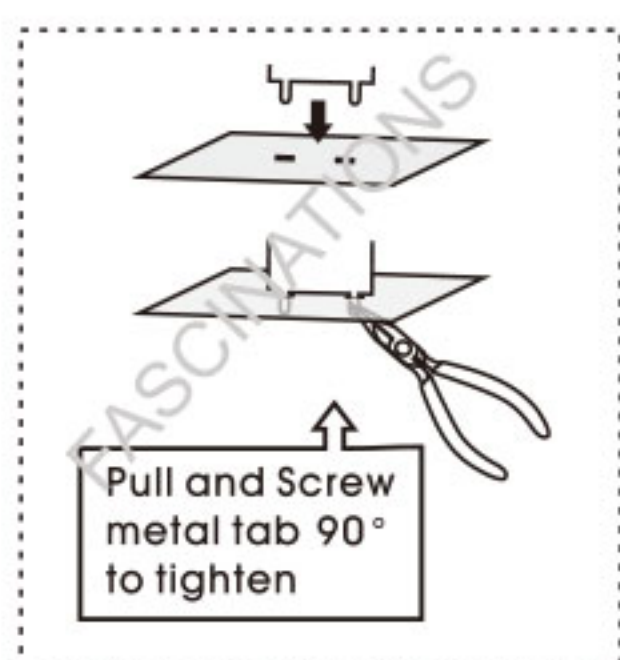

Metal sheets

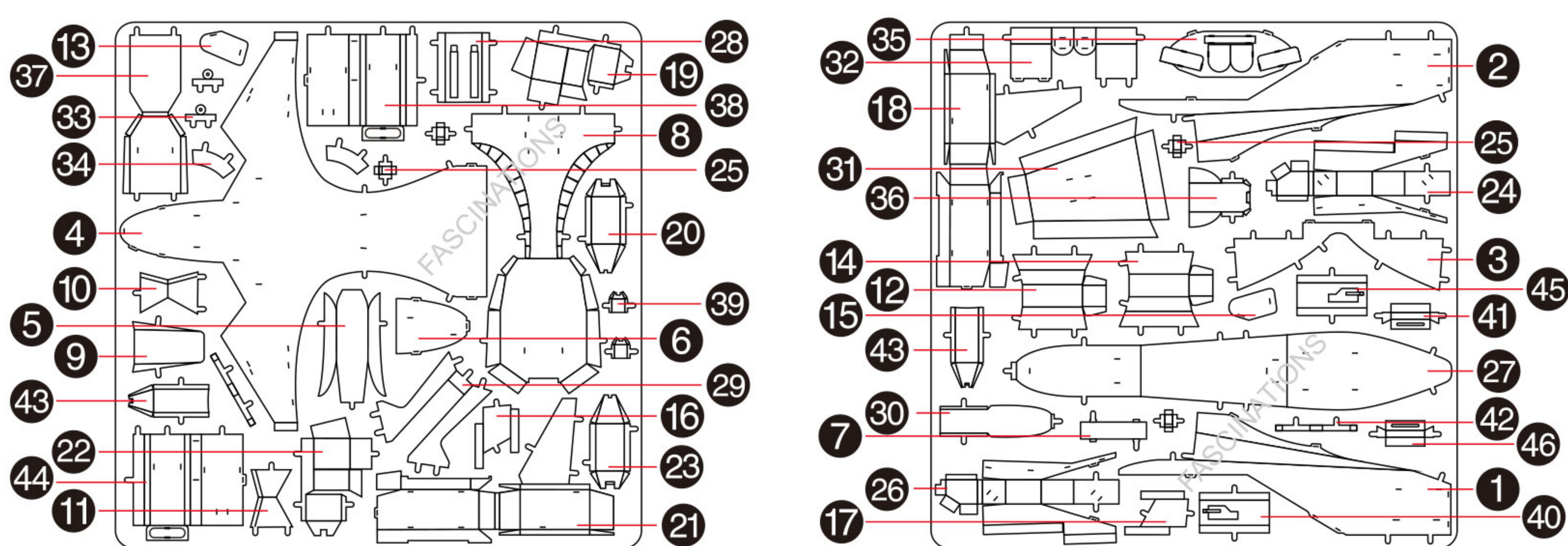

⚠ In order to avoid possible injury from sharp edges, please carefully discard the metal sheet after parts have been removed

Assembly Flow Chart

