

METAL EARTH™

3D LASER CUT MODELS

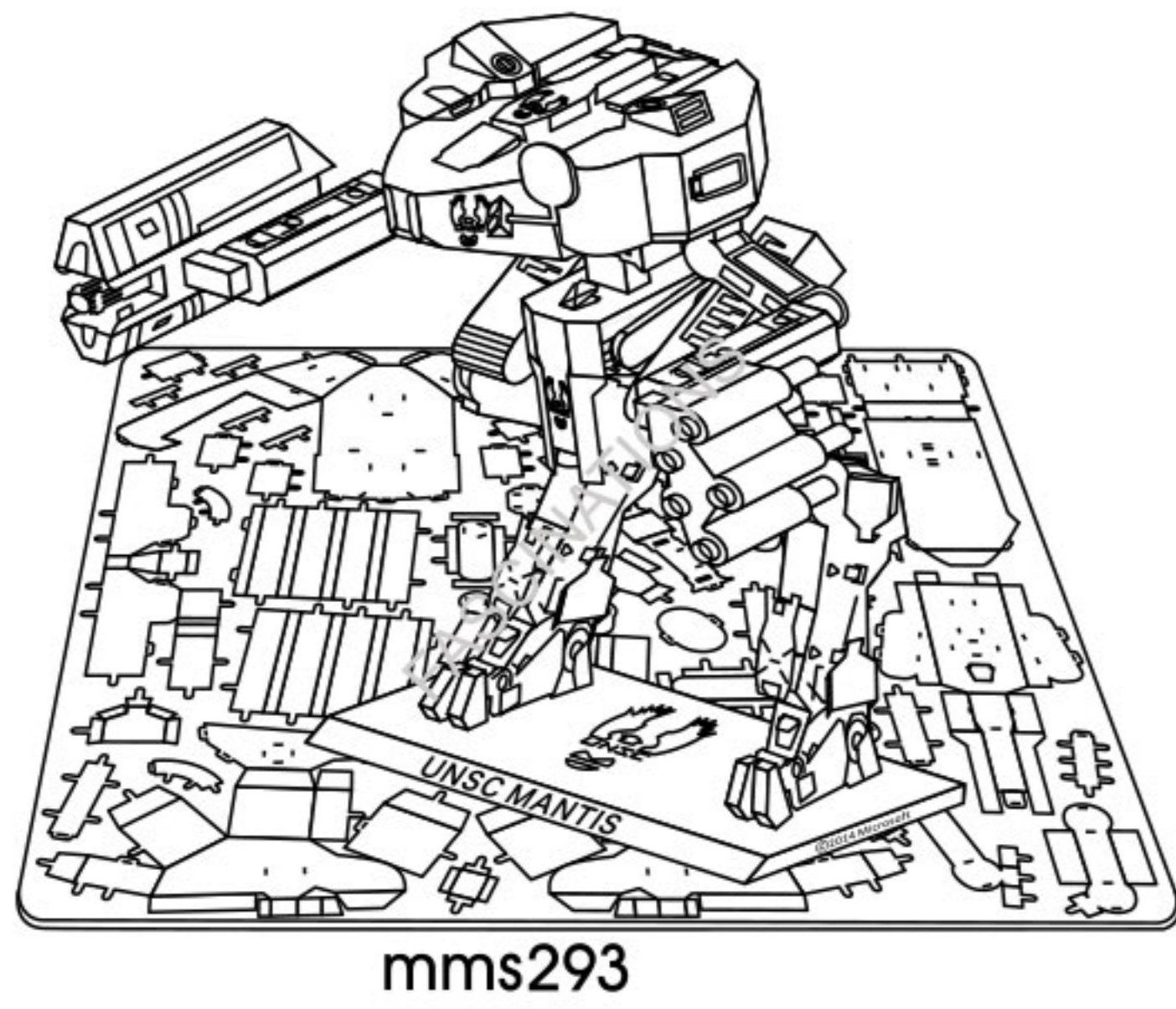

It is highly recommended that you visit www.fascinations.com/metalearth360/mms293 to see the completed model before assembling your own



To create the best connections

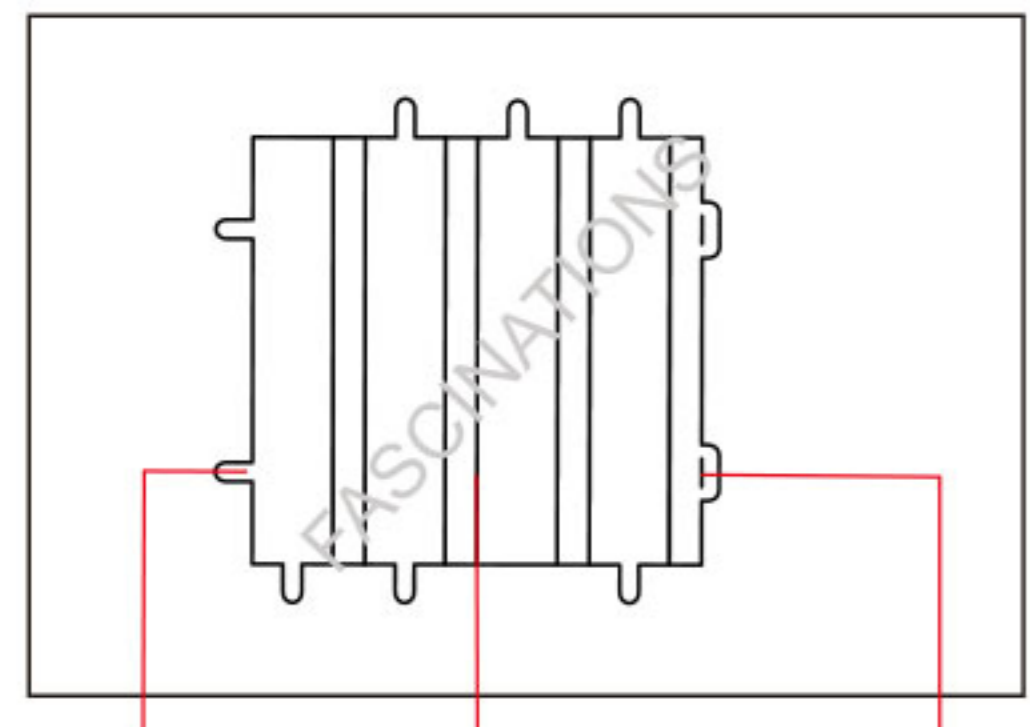

Insertion tabs are inserted and then folded
Fold lines can be seen as shown here

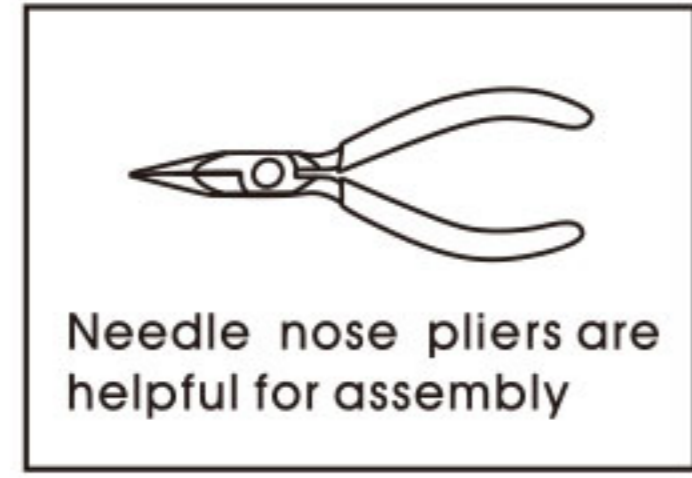

● Insert tab and bend 90 degrees for most visible areas

▲ Insert tab and twist 90 degrees is best in some areas to ensure a tight connection

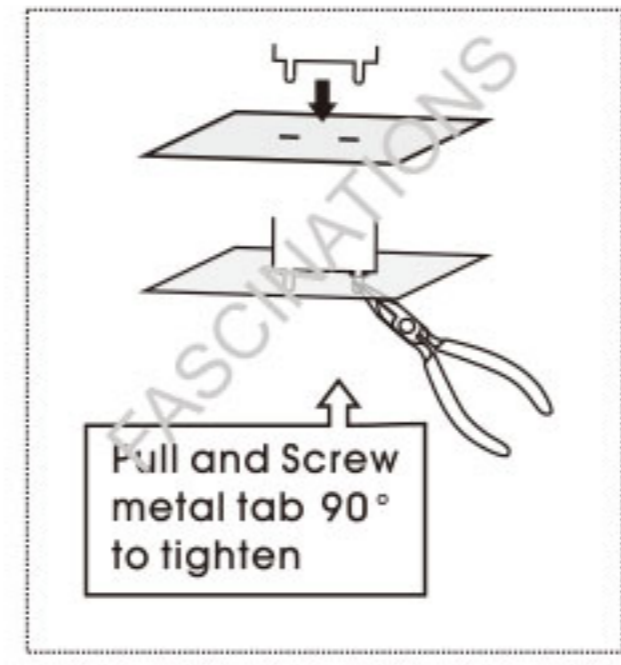

Assembly Flow Chart

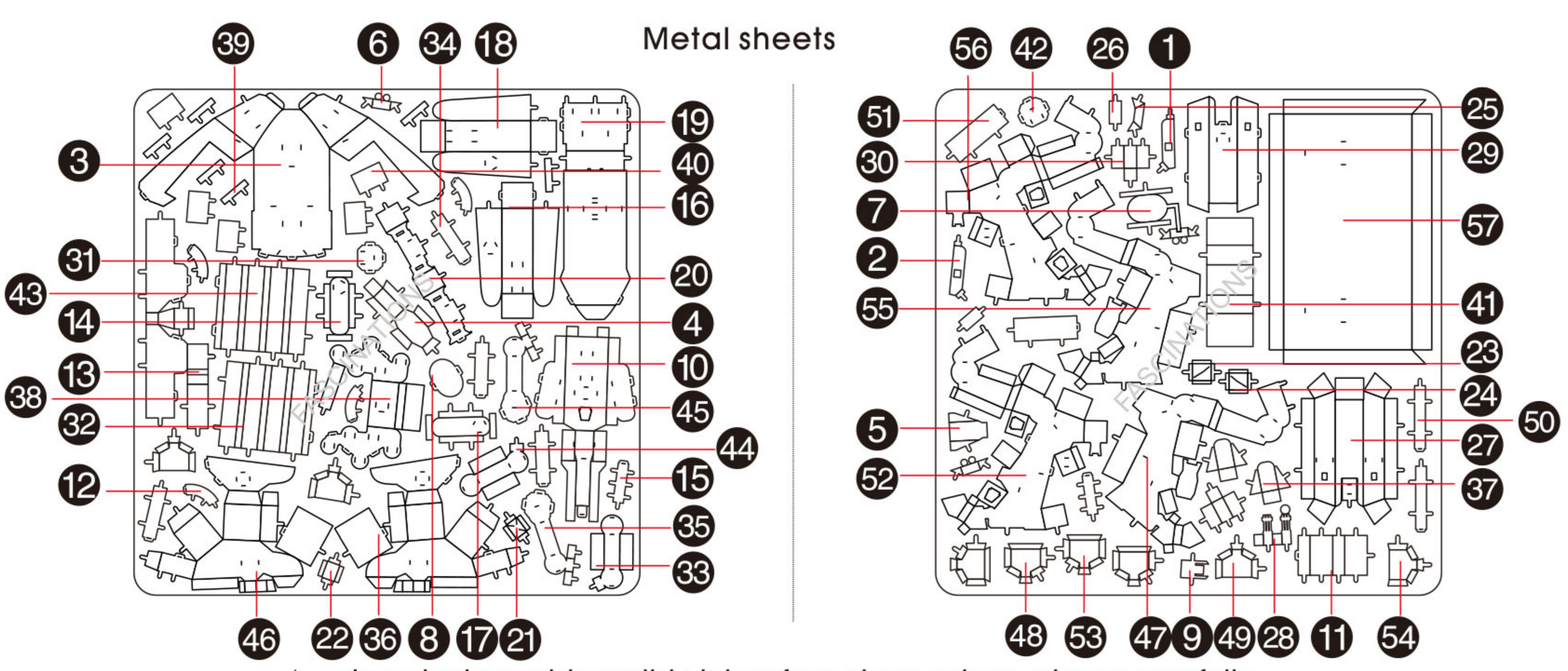
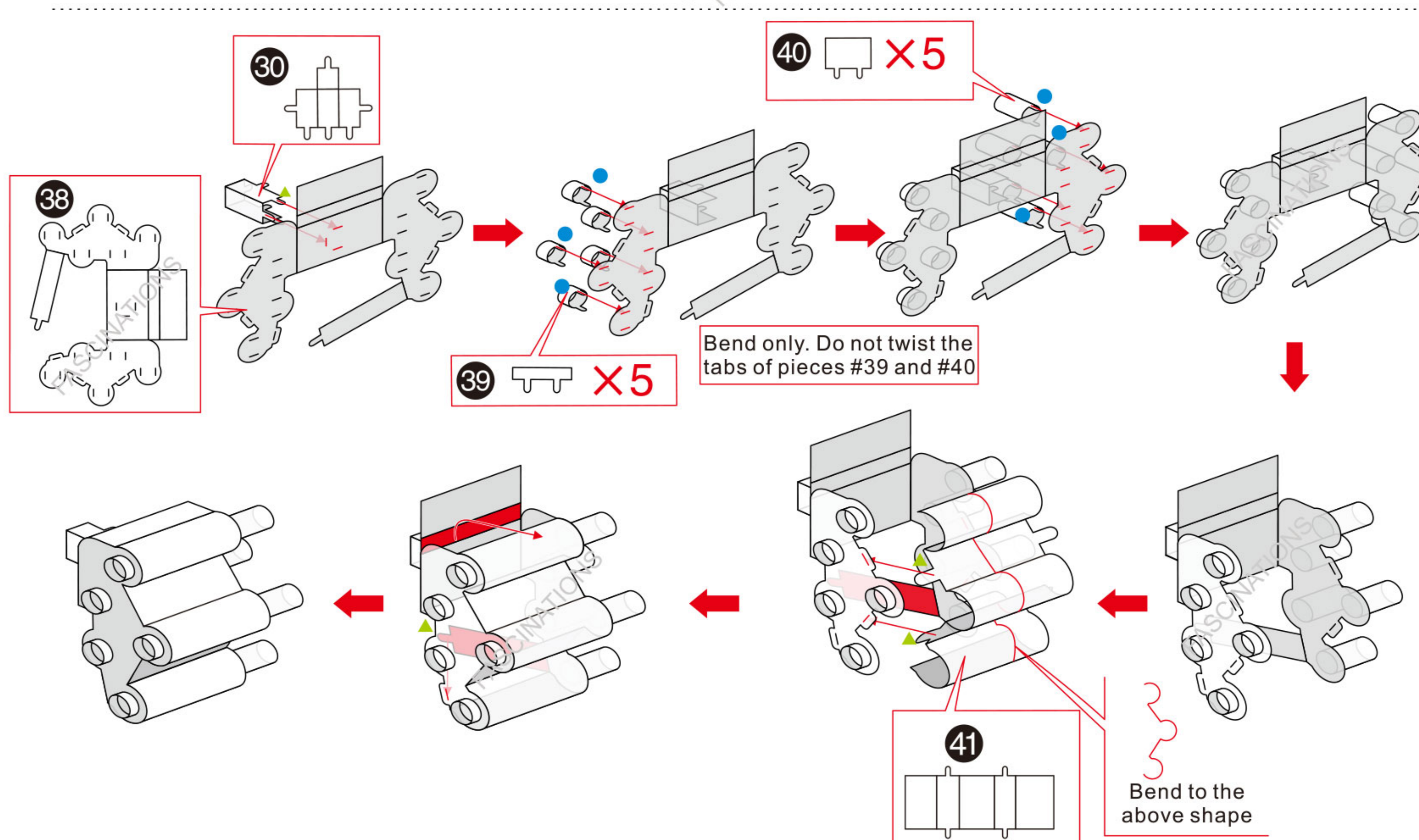
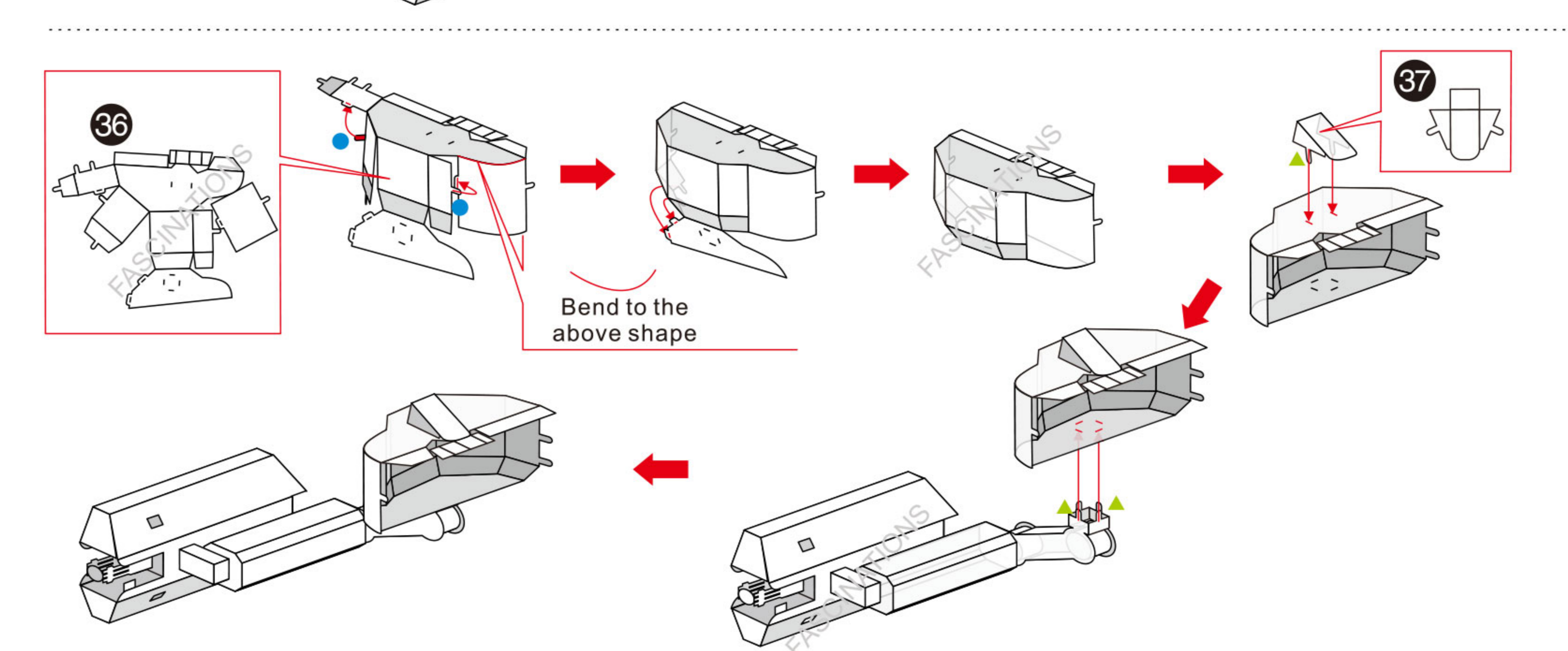
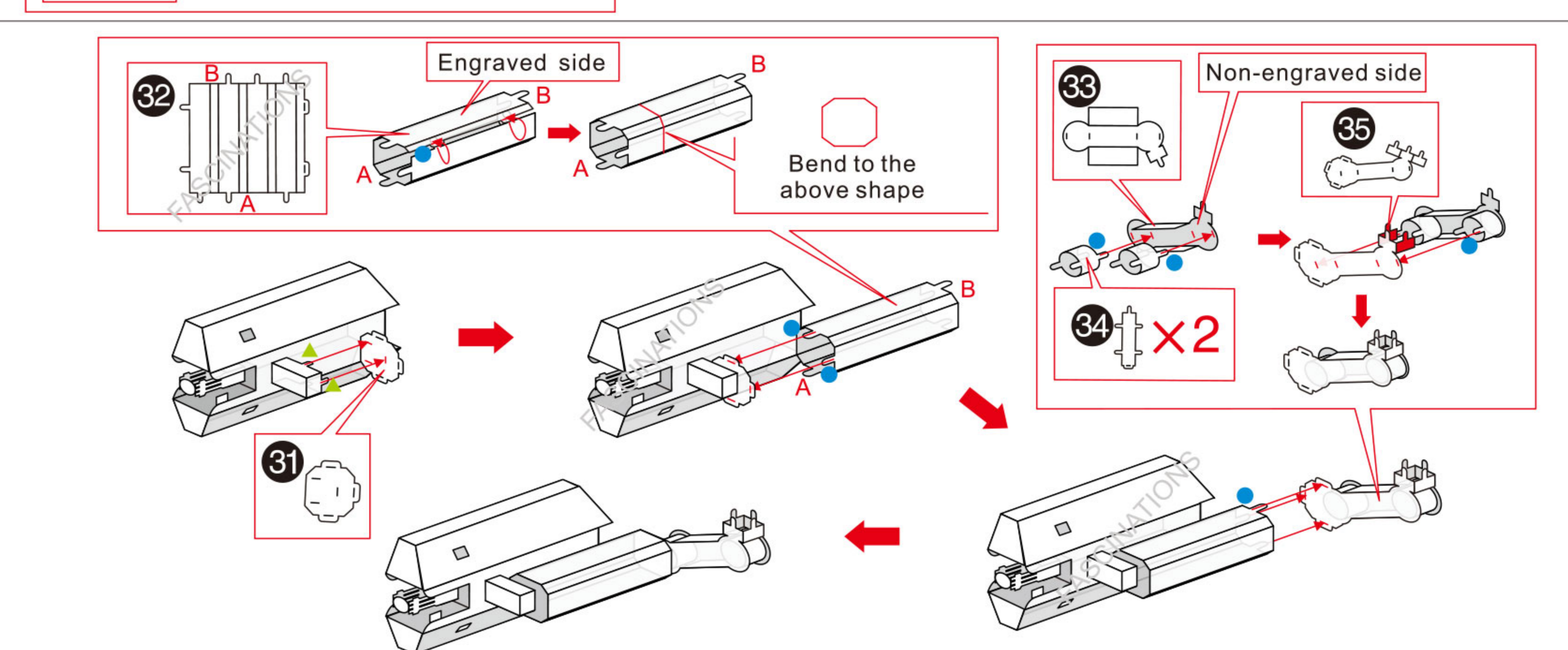
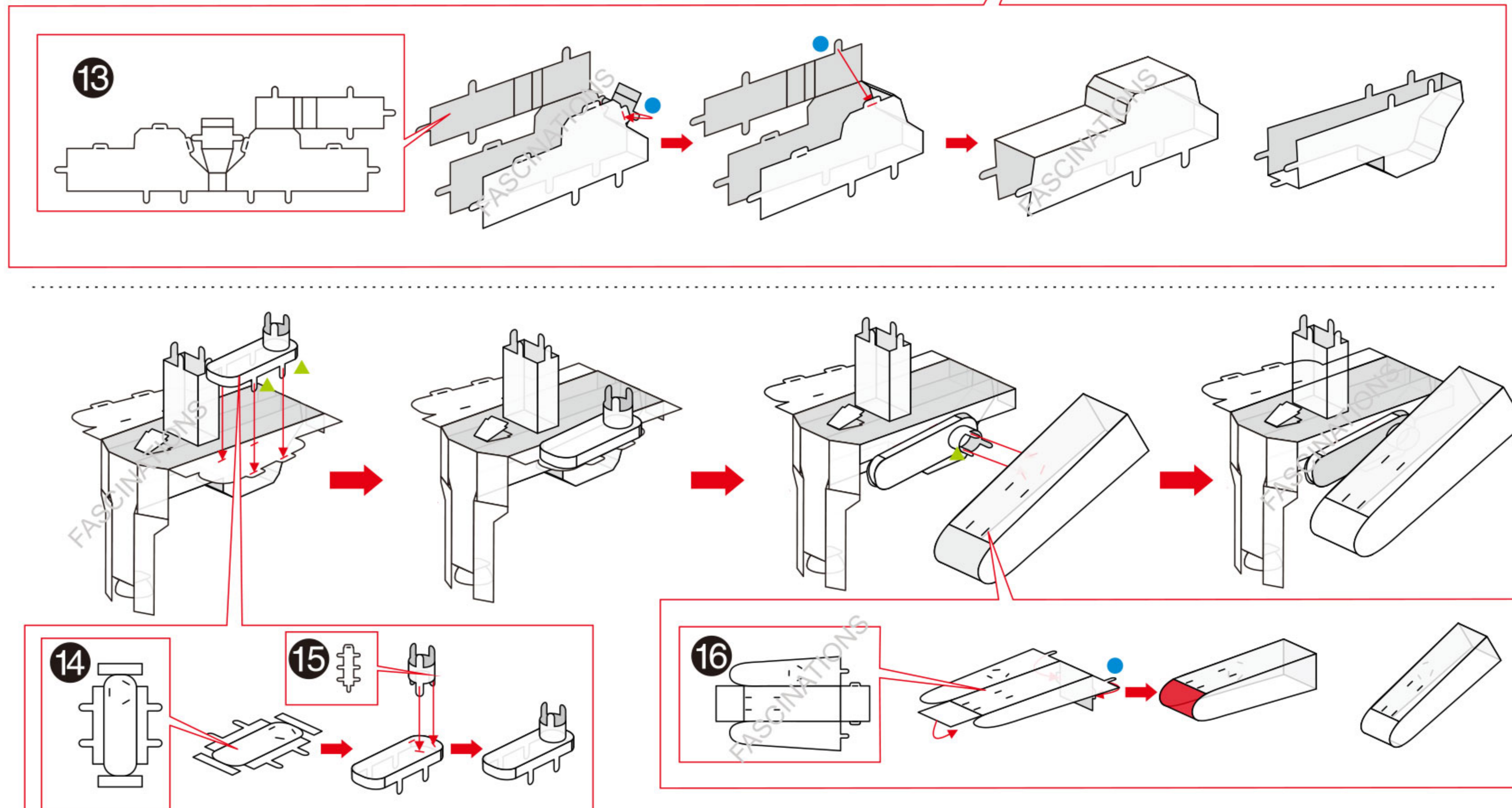
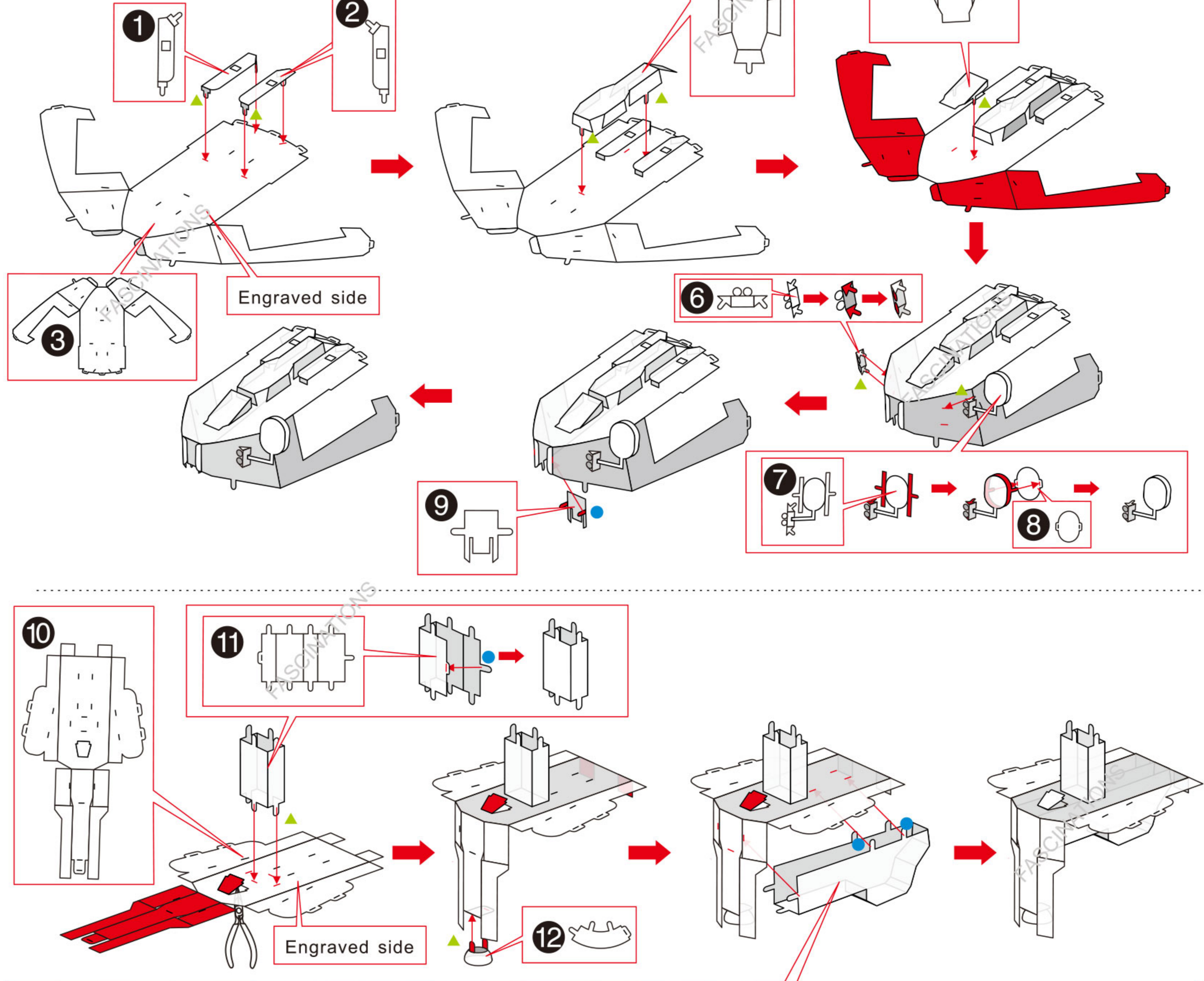

⚠ In order to avoid possible injury from sharp edges, please carefully discard the metal sheet after parts have been removed

