

# Metal Earth

3D METAL MODEL KITS

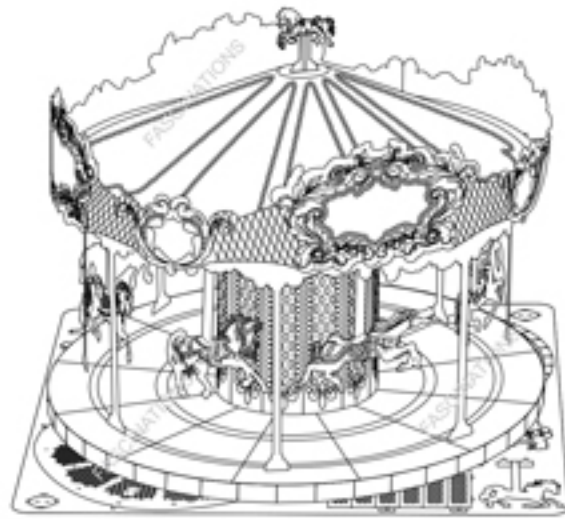

Merry Go Round  
Item No. MMS089



It is highly recommended that you visit [www.metalearth.com/360/mms089](http://www.metalearth.com/360/mms089) to see the completed model before assembling your own

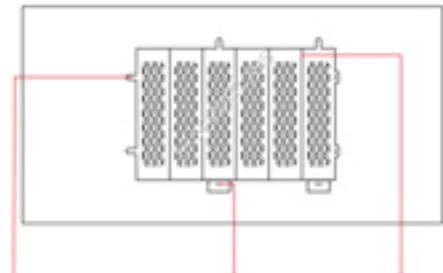

Insertion tabs are inserted and then folded

Insertion holes

Fold lines can be seen as shown here

**Legends:**

**E** Engraved side

**NE** Non-engraved side

Attention point

Insert tab and bend 90 degrees

Insert tab and twist 90 degrees

**Assembly tip:**

If needed, slightly twist tabs to hold parts together then untwist and bend them down for a nice finish

**Recommended tools:**

-Wire cutters: helpful for taking parts from the metal sheets.



-Tweezers or needle nose pliers: helpful for folding parts, bending and twisting tabs.



**Metal sheets**

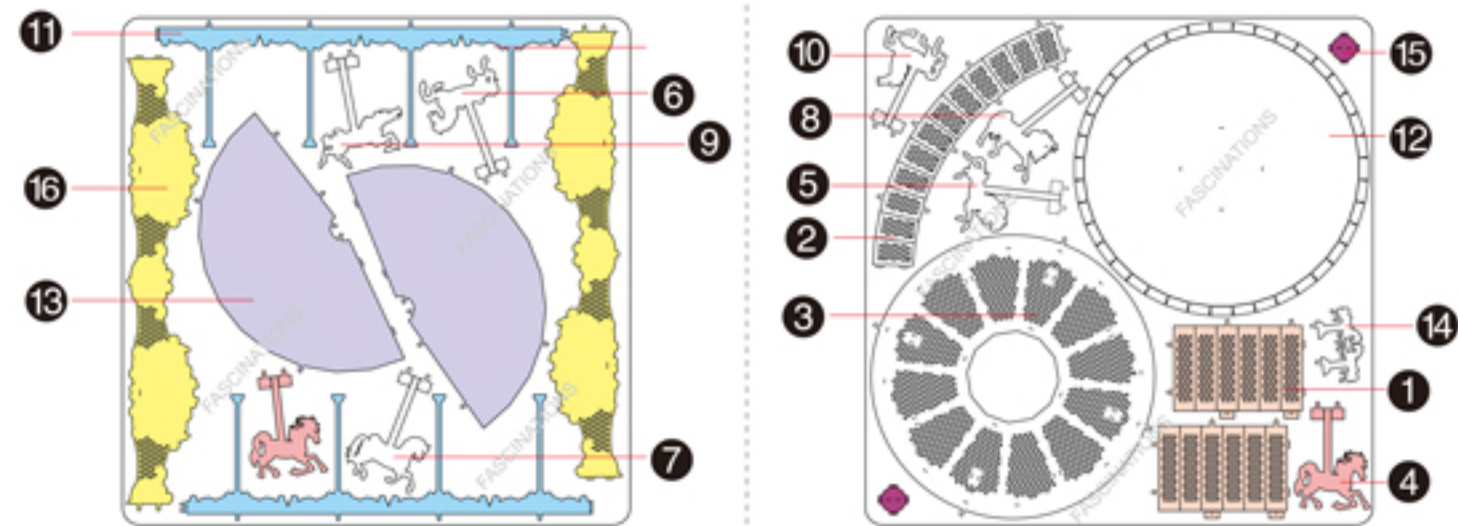

In order to avoid possible injury from sharp edges, please carefully discard the metal sheets after parts have been removed

## Assembly Flow Chart

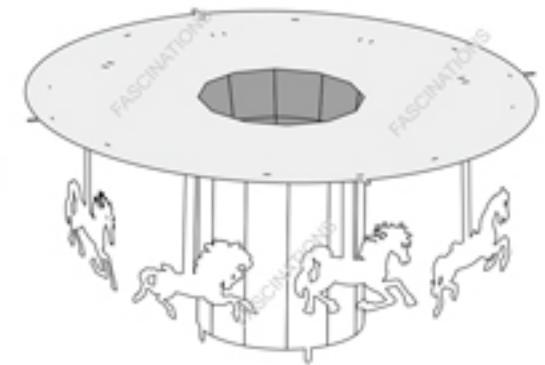
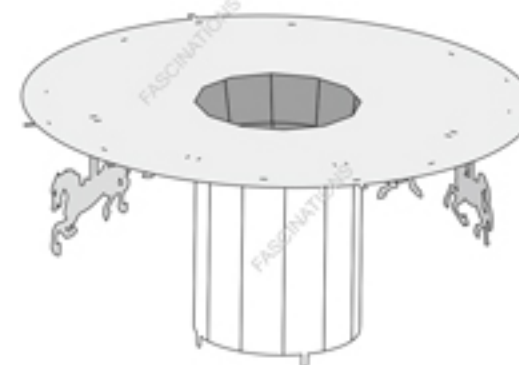
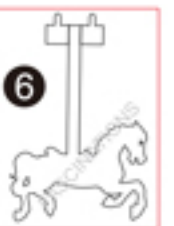
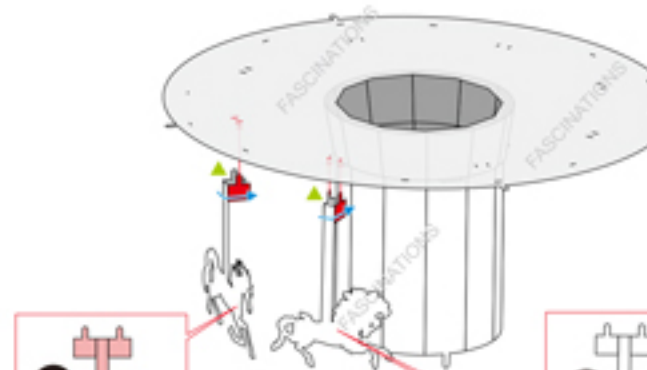
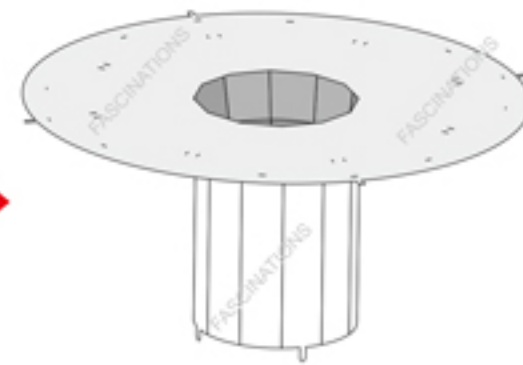
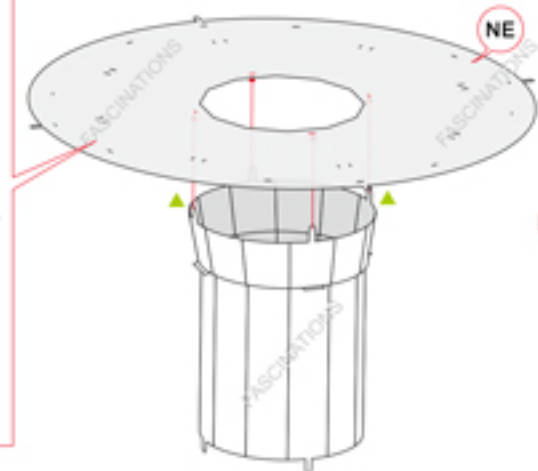
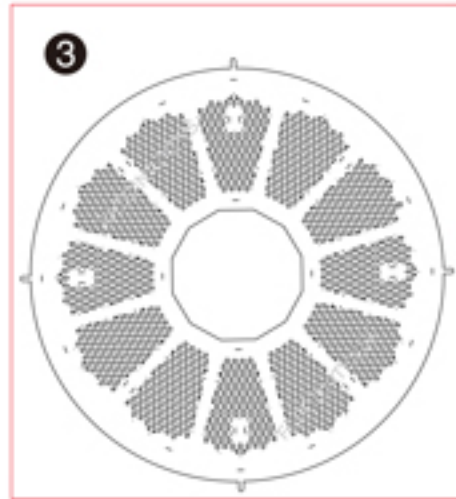
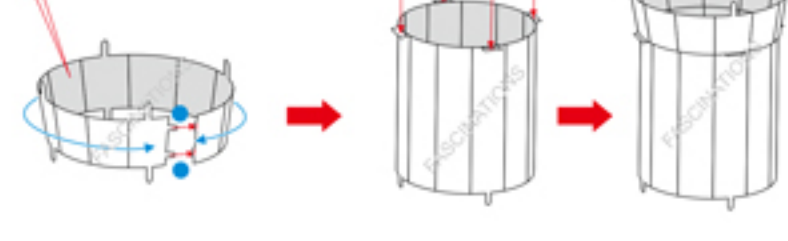
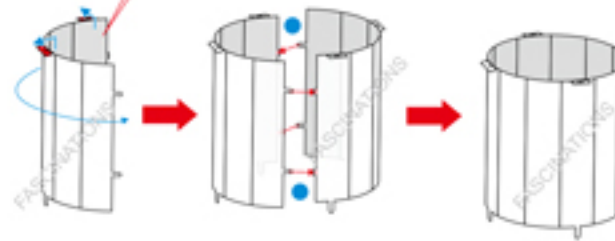
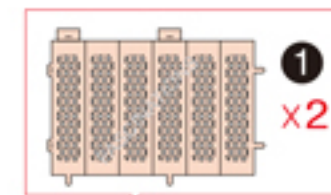

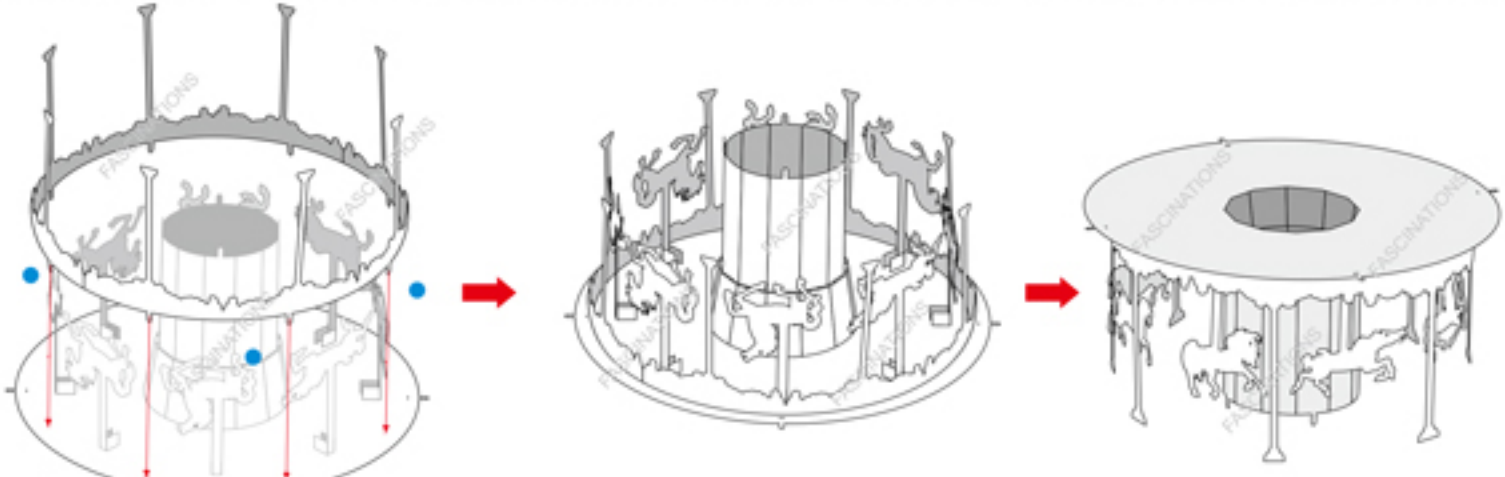
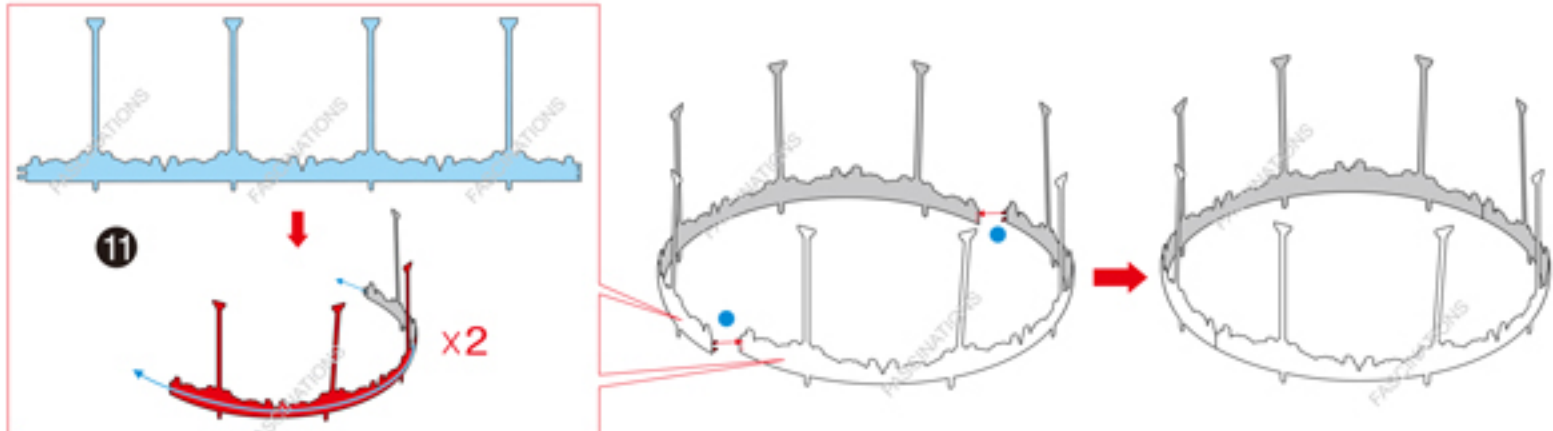
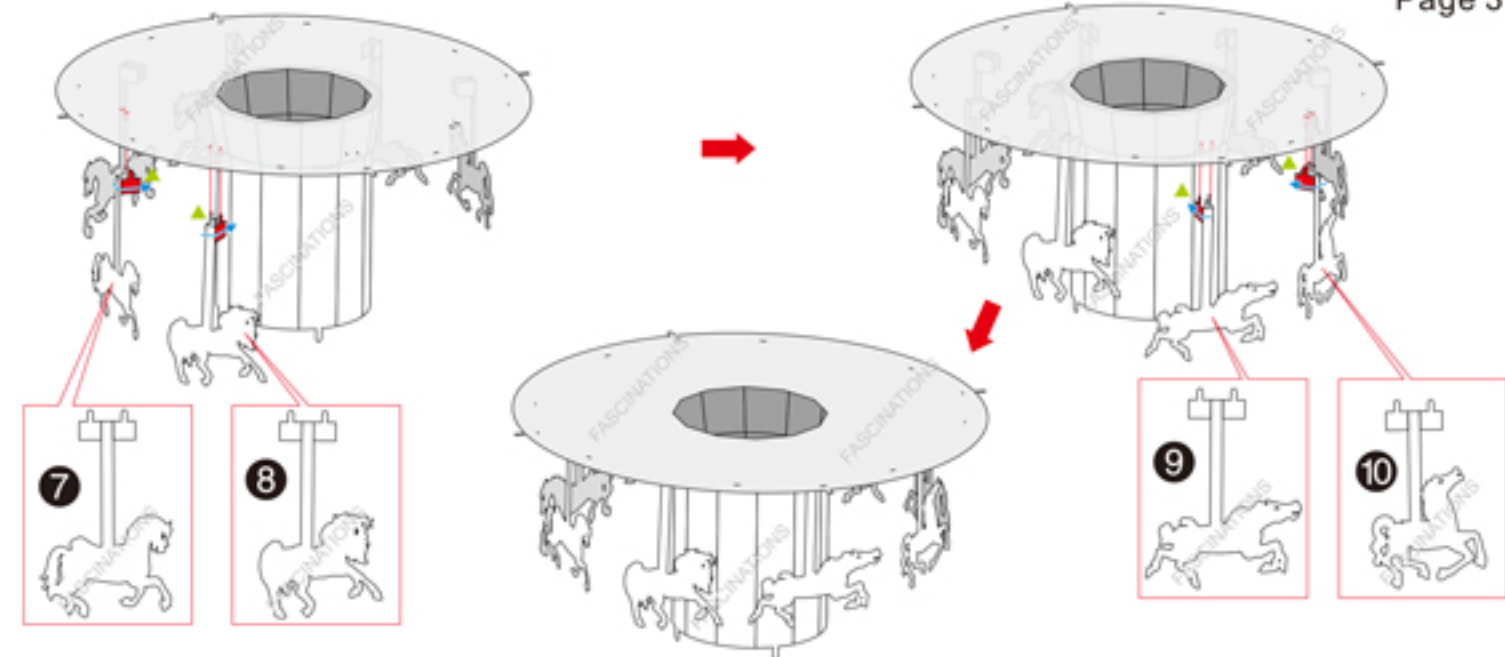

These tabs must be bent down. Do not twist them.

