

ASSEMBLY INSTRUCTIONS

REMOVE PARTS FROM PLASTIC WRAP

CHECK ALL OF THE FOLLOWING PARTS ARE INCLUDED:

- 1 x Metal Base
- 1 x Center Pole
- 1 x Square Display Tray
- 6 x Support Rod
- 1 x Plastic Washer
- 7 x Pole Extender
- 7 x Short Screw
- 7 x Long Screw
- 2 x Hook Plate
- 1 x Hex Key

You can view the assembly video at:
www.fascinations.com/wire2tier

ASSEMBLY STEPS

1 Screw the center pole onto the metal base as shown. Then slide the plastic washer over the top of the pole.

2 Slide one of the hook plates down the center pole with the hooks pointed up.

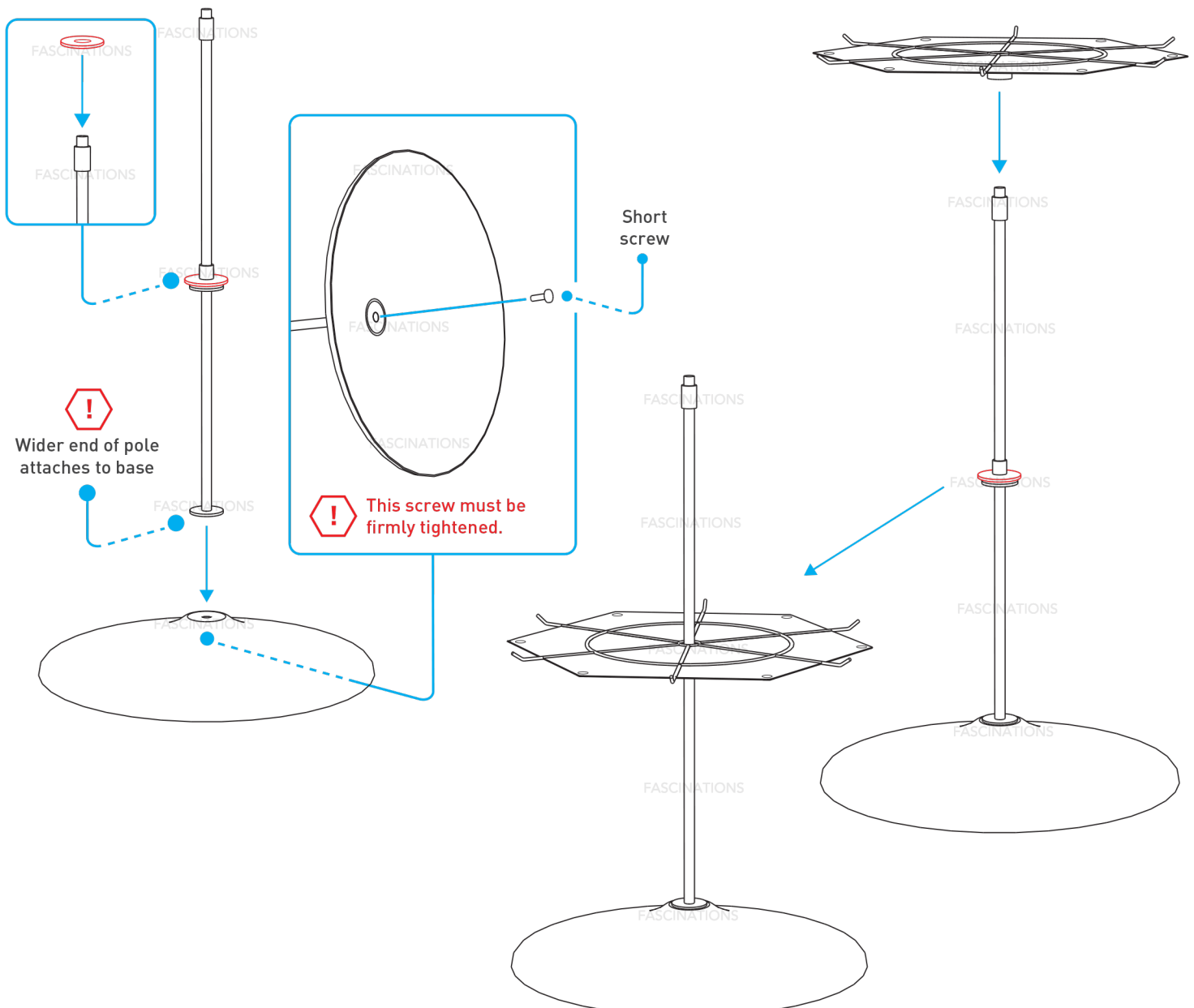

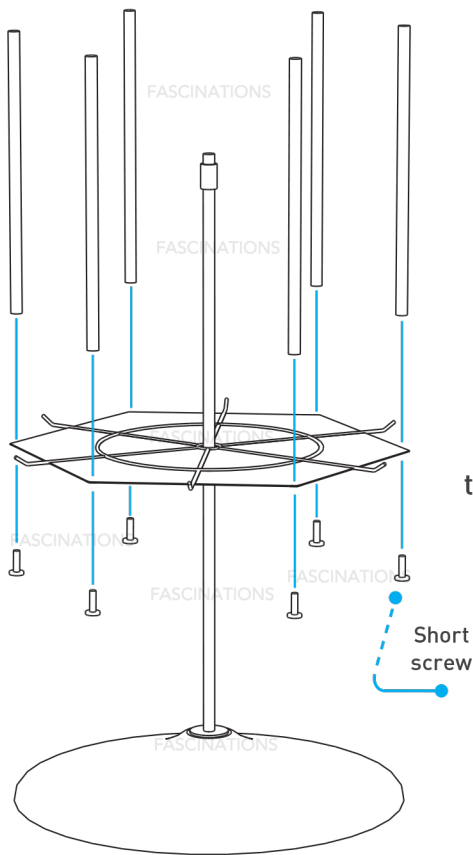

3

Screw the 6 support rods onto the plate as shown in the illustration to the left using the short screws.

4

Slide the second hook plate down the center pole with hooks up as shown in the illustration to the right.

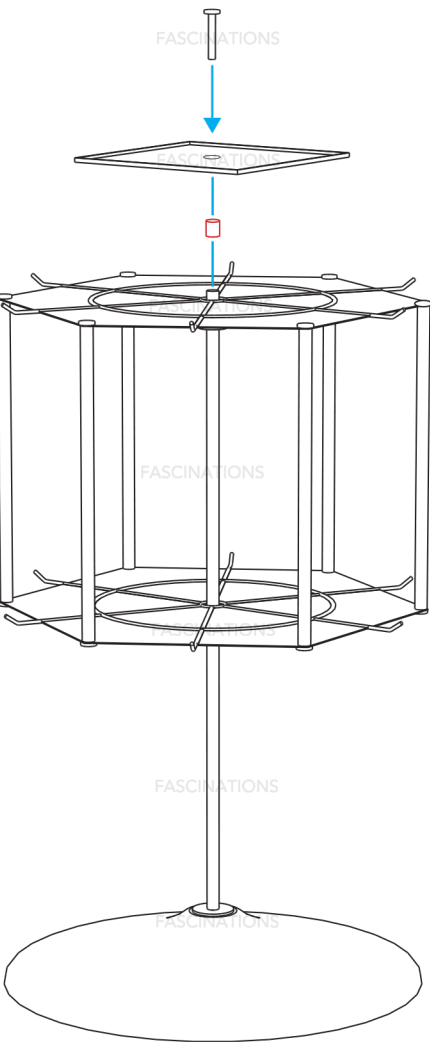

5

Attach the hook plate by inserting 6 long screws through the hook plate then through the pole extender and then into the top of the support rods.

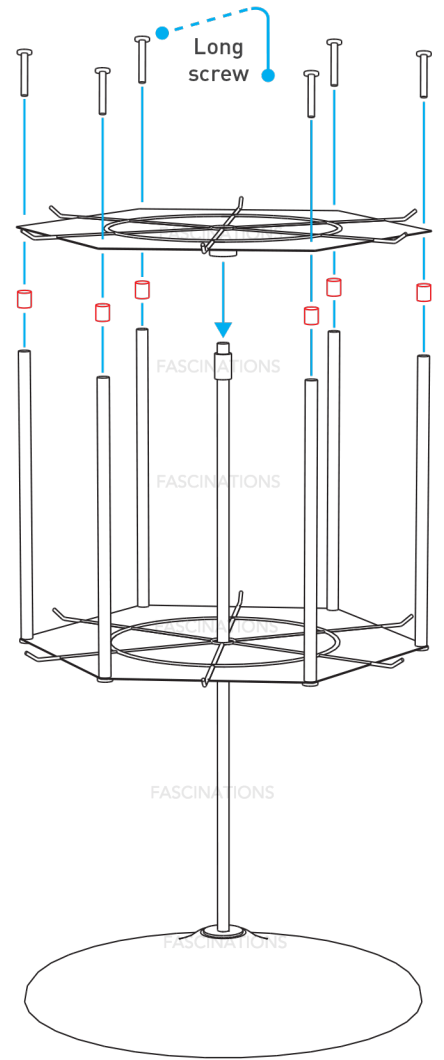

6

Insert one long screw through the square tray then through the pole extender before securing it to the top of the center pole.

Display diameter: 9.6" (24cm)
Height: 16.9" (43cm)

FINISHED!

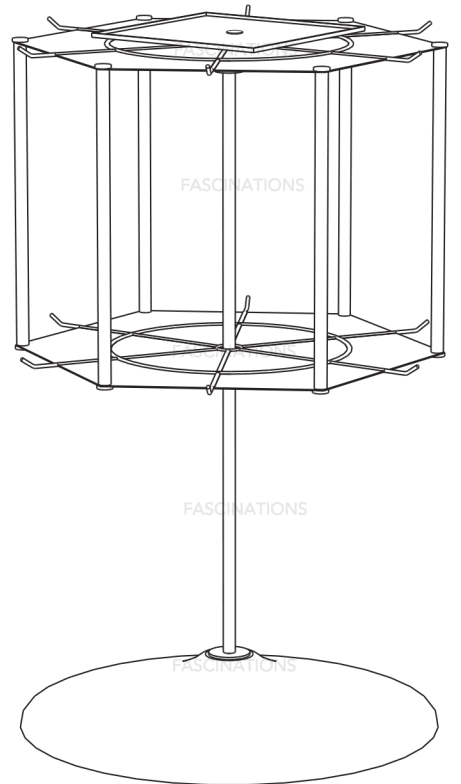

If you have any problems assembling this display or there are missing parts, please give us a call, so we can help: [206-870-3000](tel:206-870-3000) (8-4 PST). You can also email us at: support@fascinations.com

© Fascinations, Inc. All rights reserved.

Item #MMDWRS2



MADE IN VIETNAM