

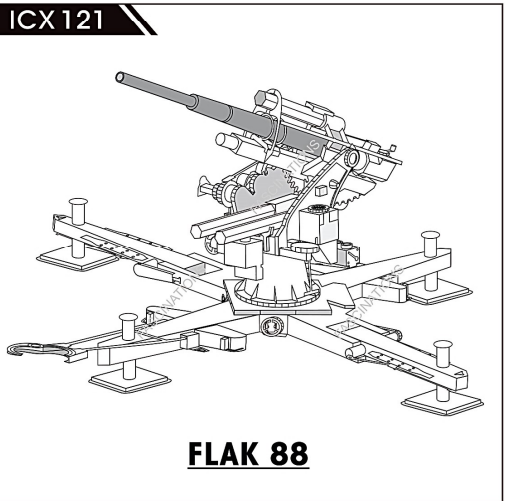

It is highly recommended that you visit www.metalearth.com/360/icx121 to see the completed model before assembling your own

Go to www.metalearth.com/360/icx121 to see the zoomable PDF version of this instruction sheet



TO CREATE THE BEST CONNECTIONS

Legends:

- E** Engraved side
- NE** Non-engraved side
- Hand icon** Attention point
- Blue circle** Insert tab and bend 90 degrees
- Green triangle** Insert tab and twist 90 degrees

Recommended tools:

- Wire cutters: helpful for taking parts from the metal sheets.
- Tweezers or needle nose pliers: helpful for folding parts, bending and twisting tabs.

Assembly tip:
If needed, slightly twist tabs to hold parts together then untwist and bend them down for a nice finish

ASSEMBLY STEPS

Step 1

Step 2

Step 3

METAL SHEETS

Parts that are in the same color are duplicates

A

B

C

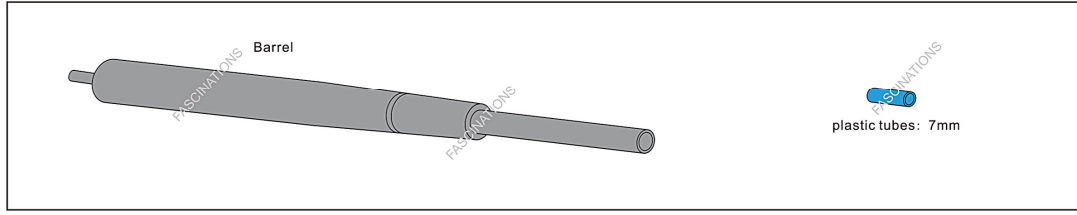

! In order to avoid possible injury from sharp edges, please carefully discard the metal sheets after parts have been removed.

Step 4

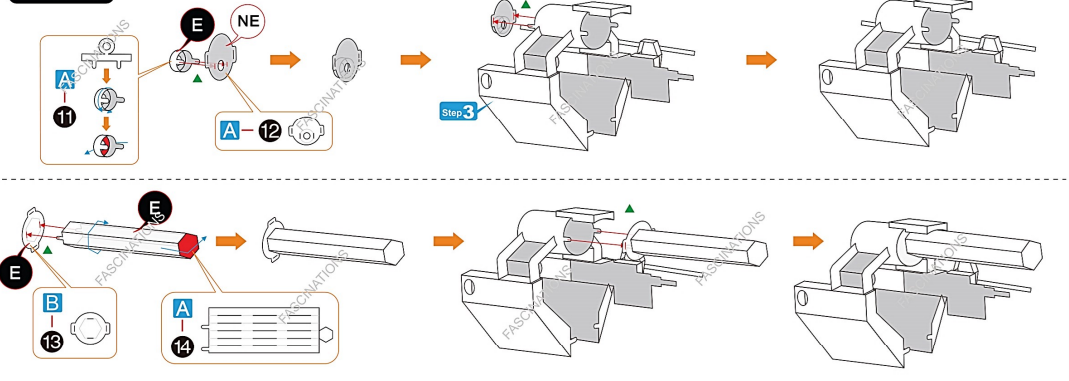

Step 5

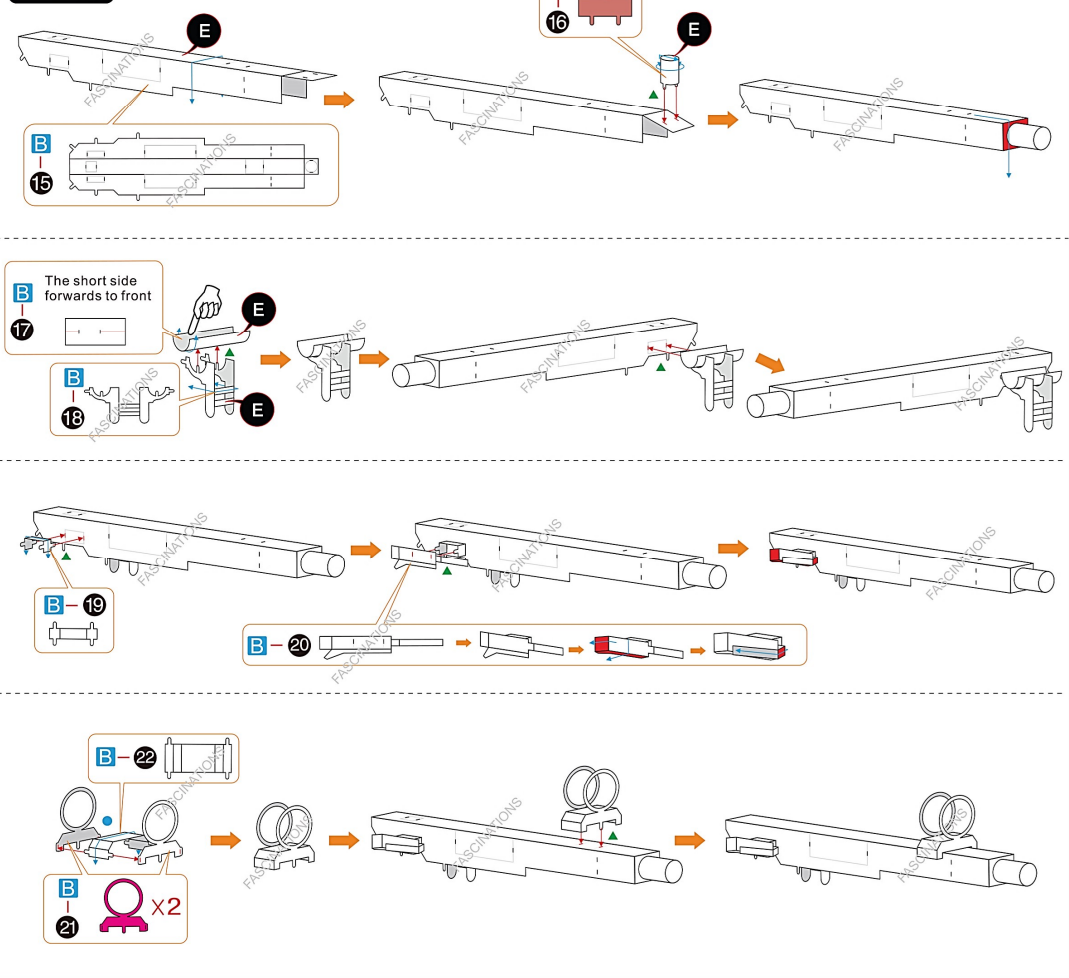

Step 6

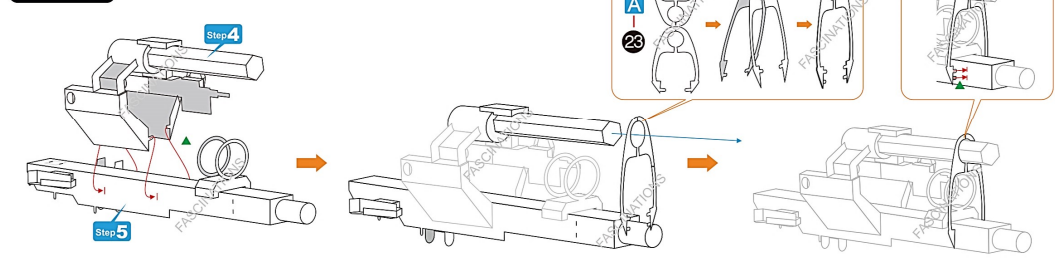

Step 7

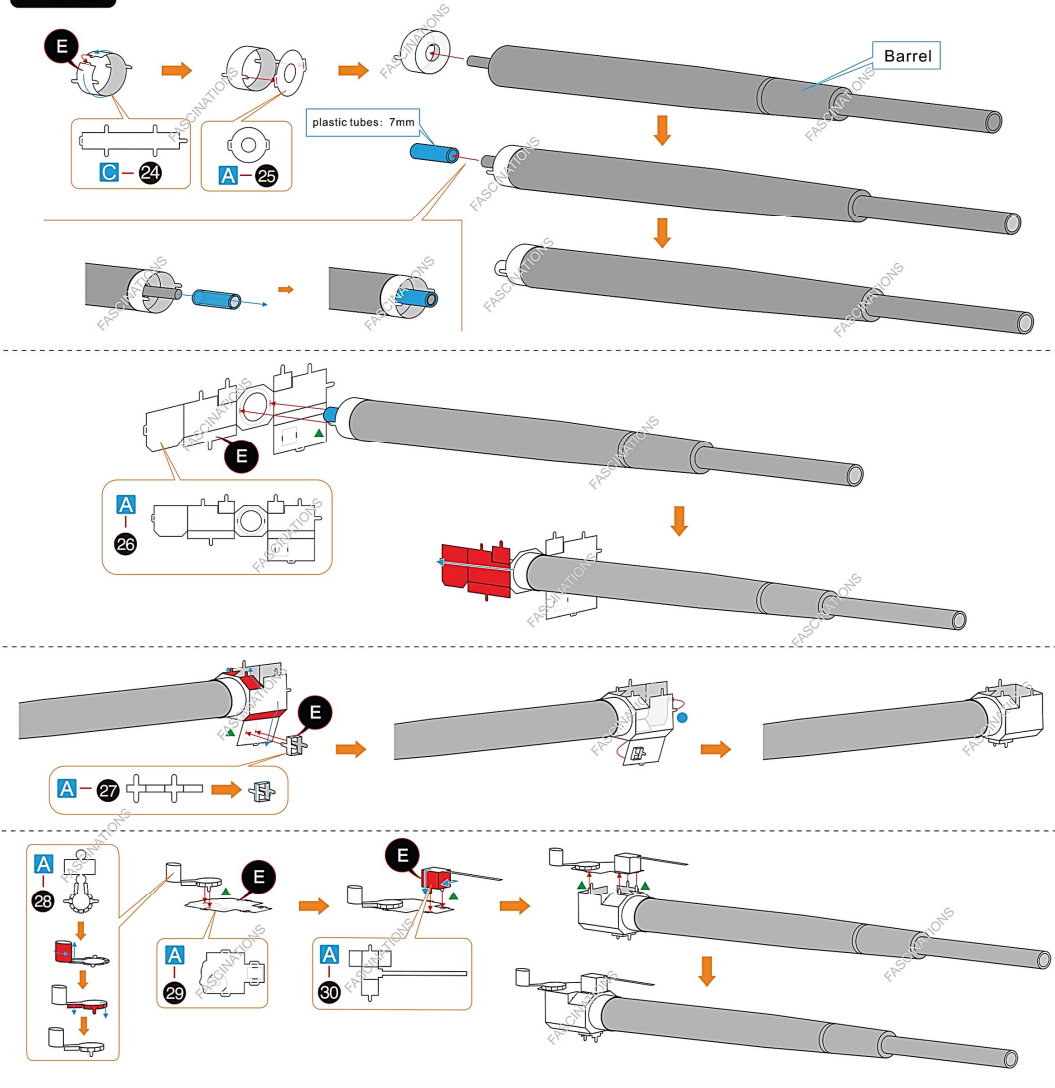

Step 8

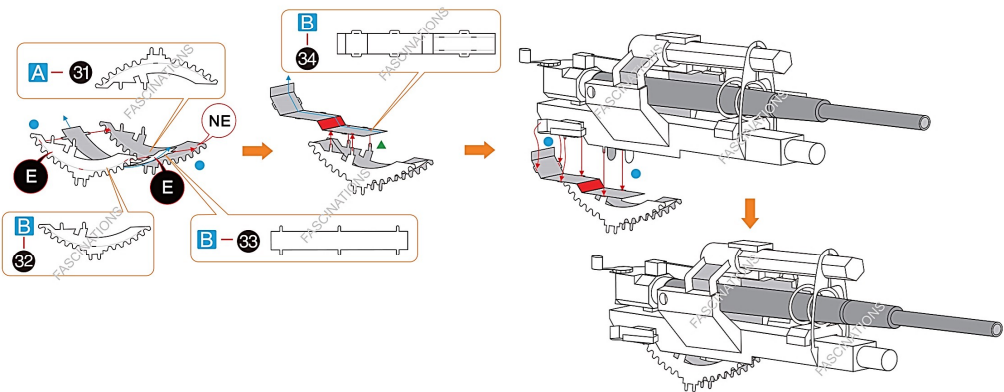
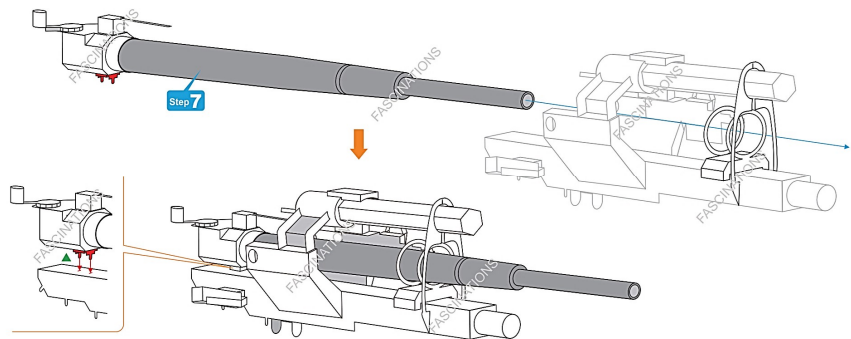

Step 9

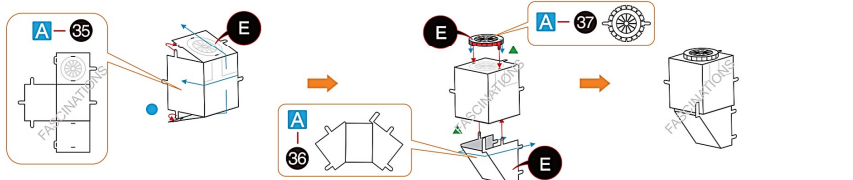

Step 10

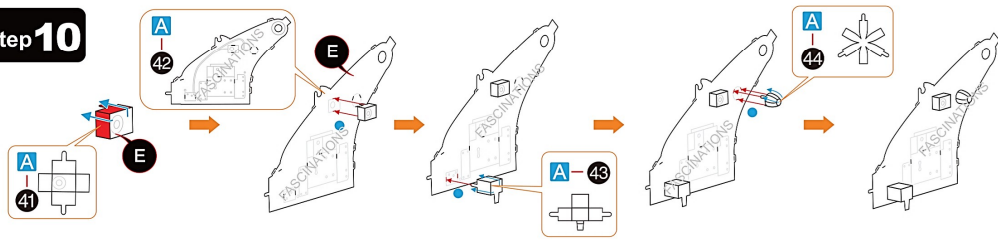

Step 11

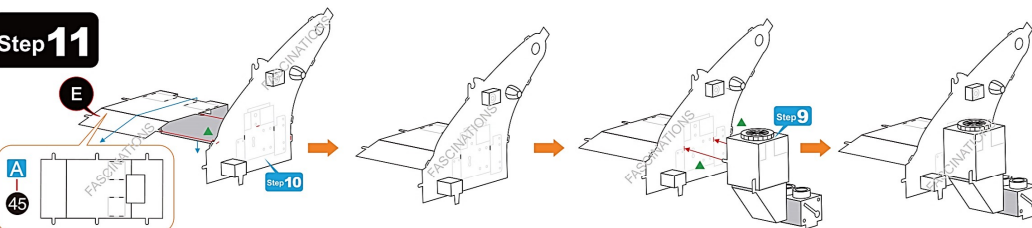

Step 12

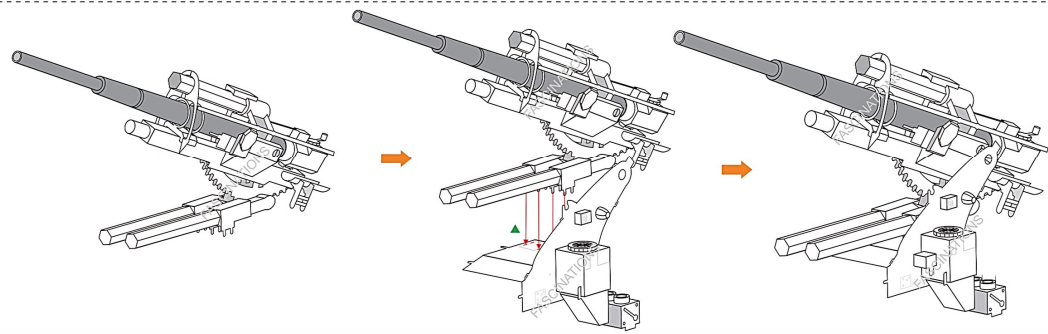
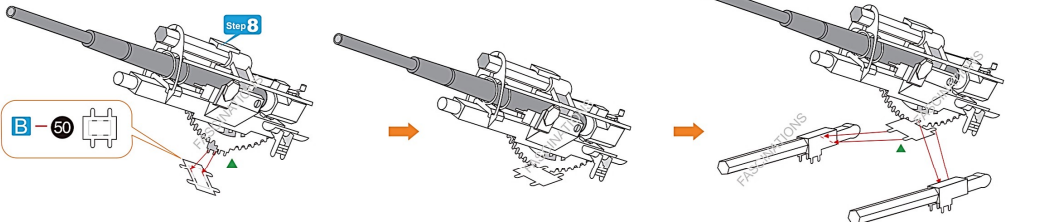
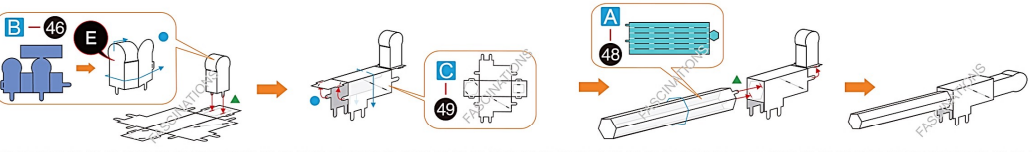
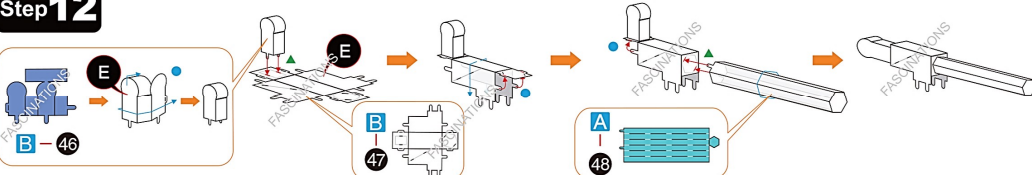

Step 13

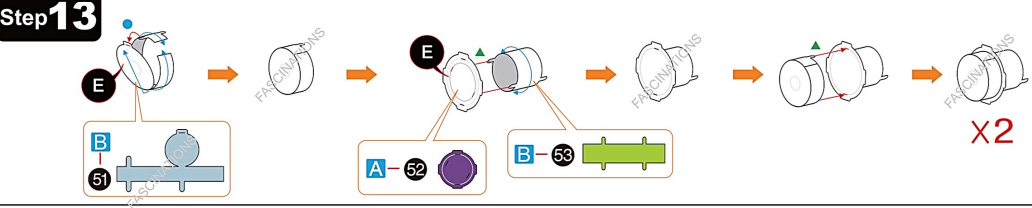

Step 14

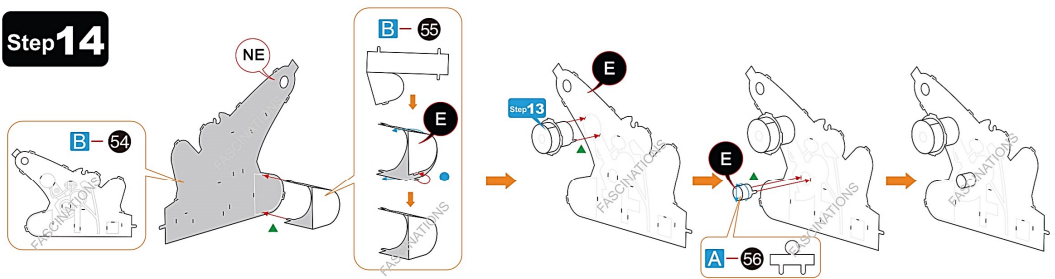

Step 12

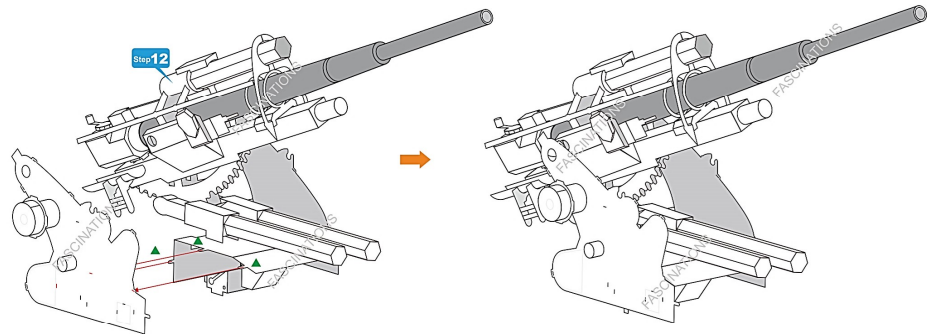

Step 15

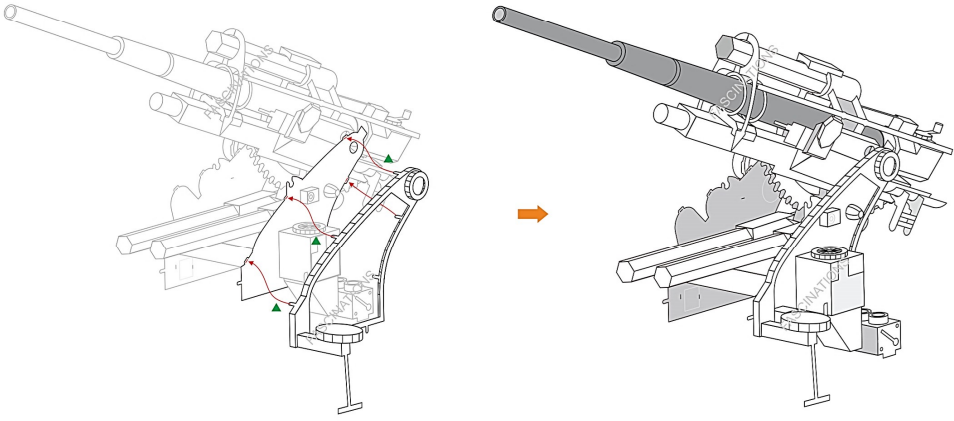
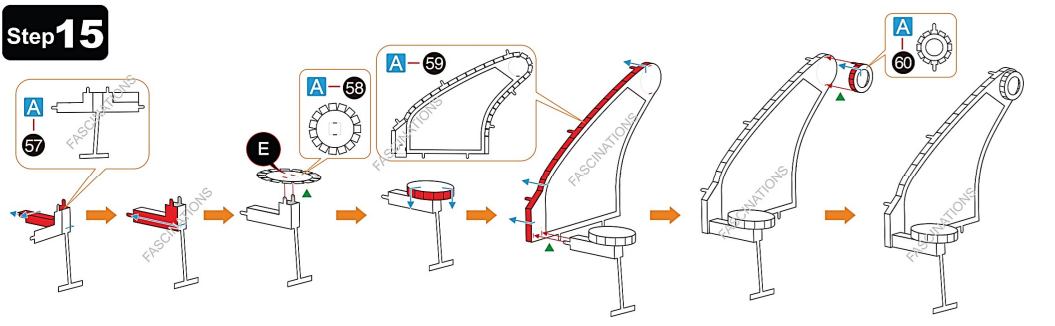

Step 16

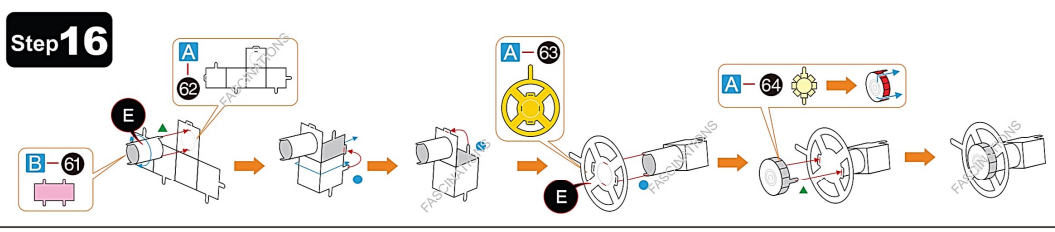

Step 17

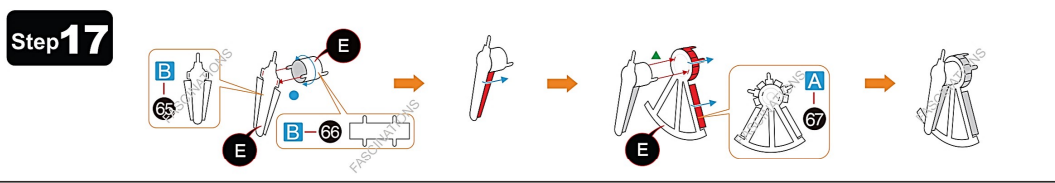

Step 18

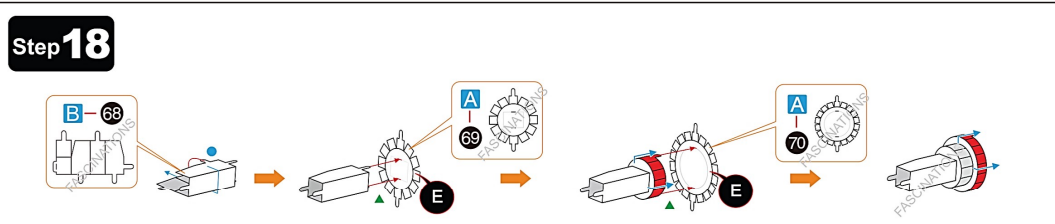

Step 19

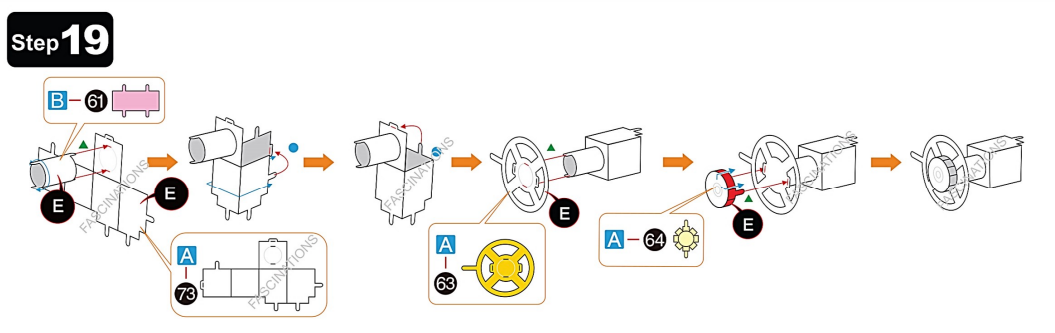

Step 20

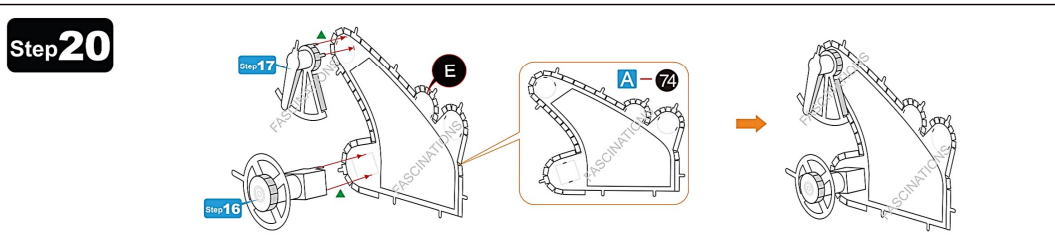

Step 21

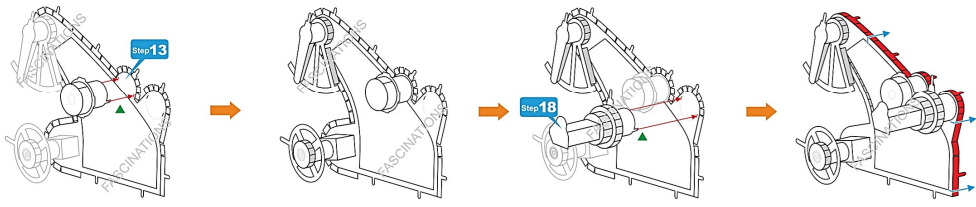

Step 22

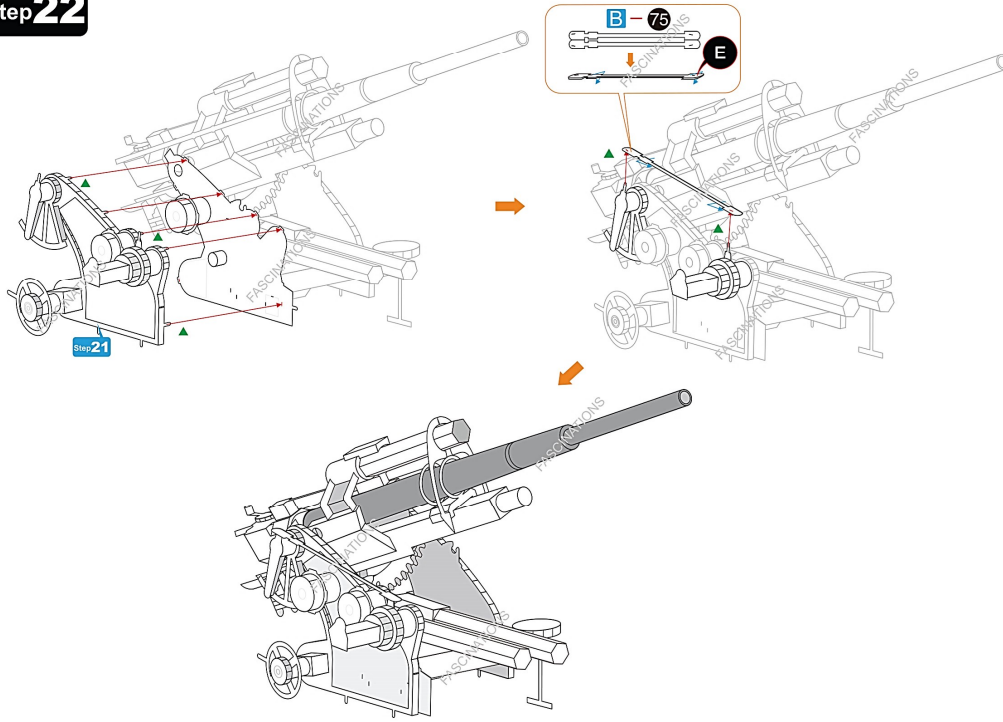

Step 23

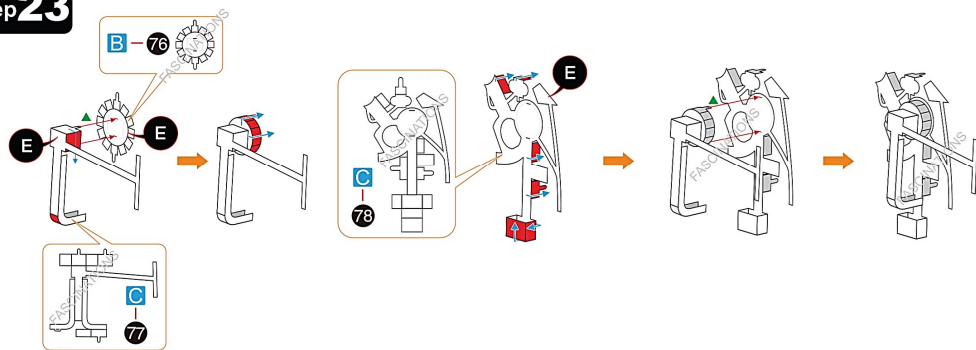

Step 24

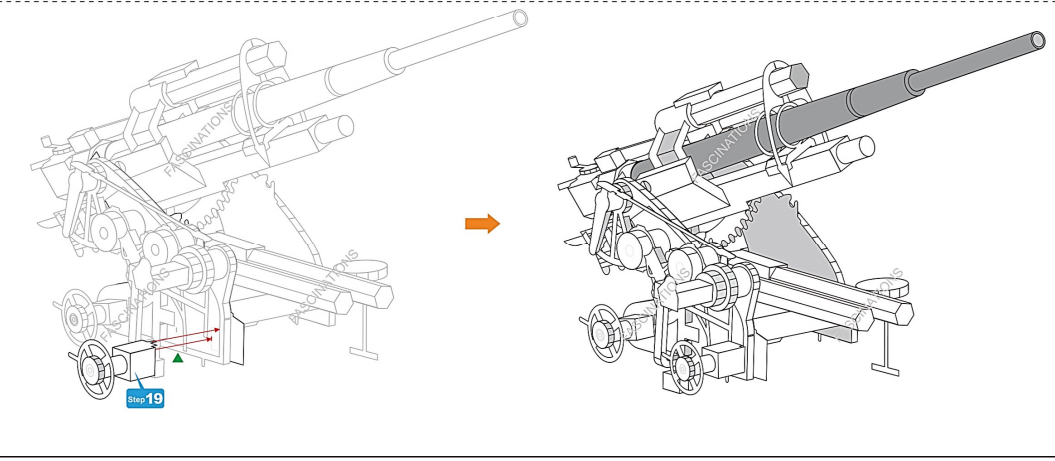
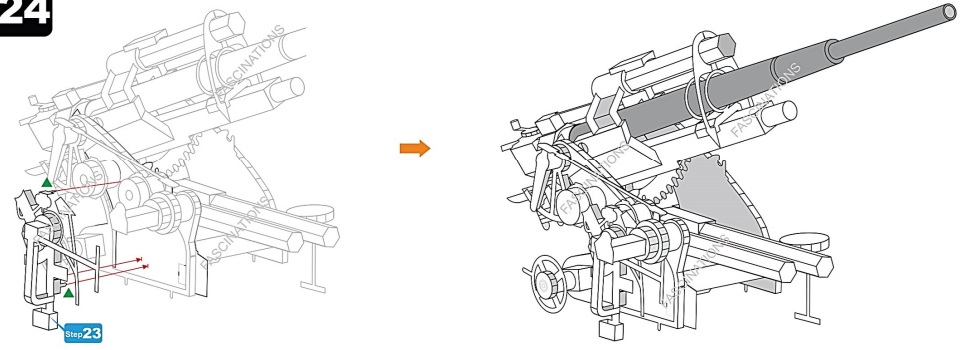

Step 25

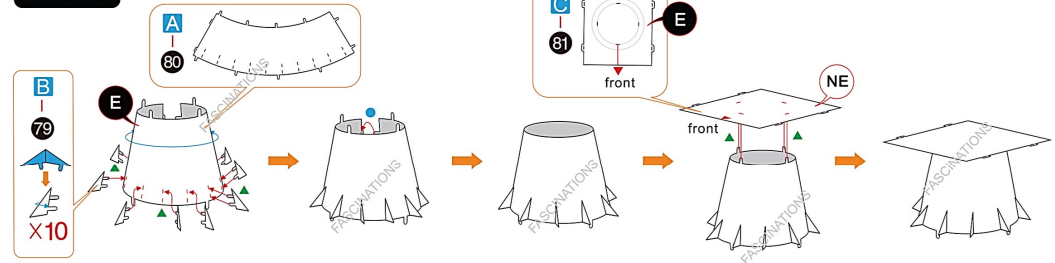

Step 26

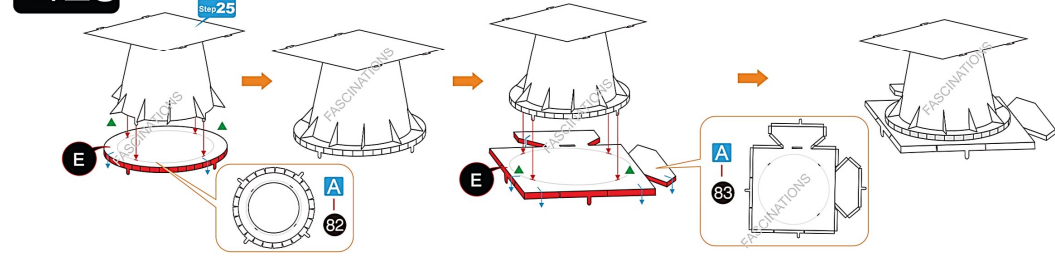

Step 27

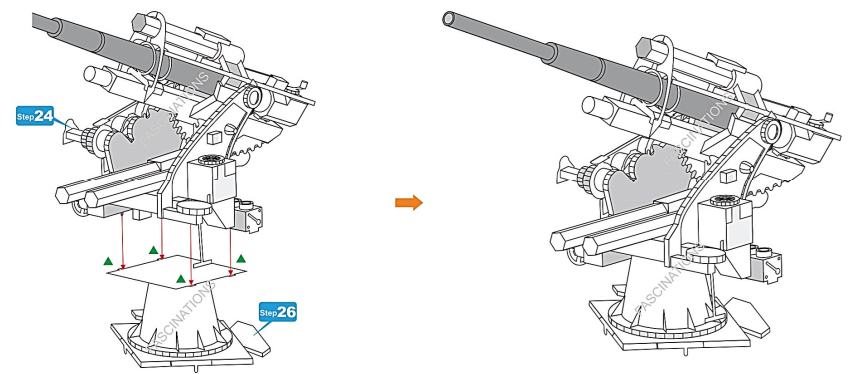

Step 28

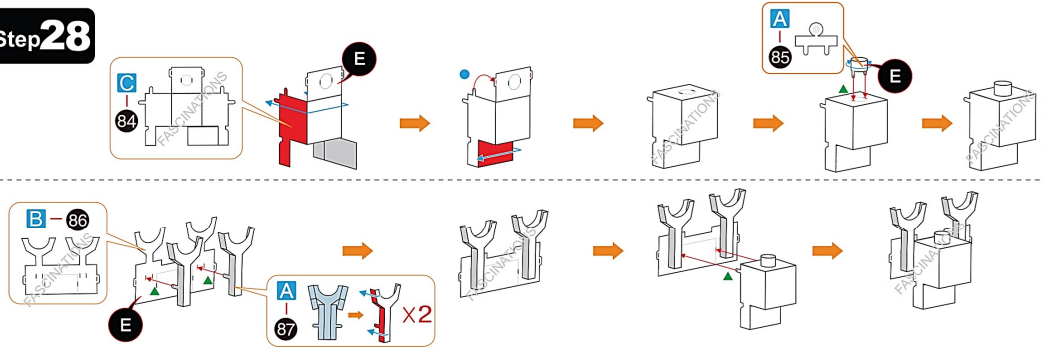

Step 29

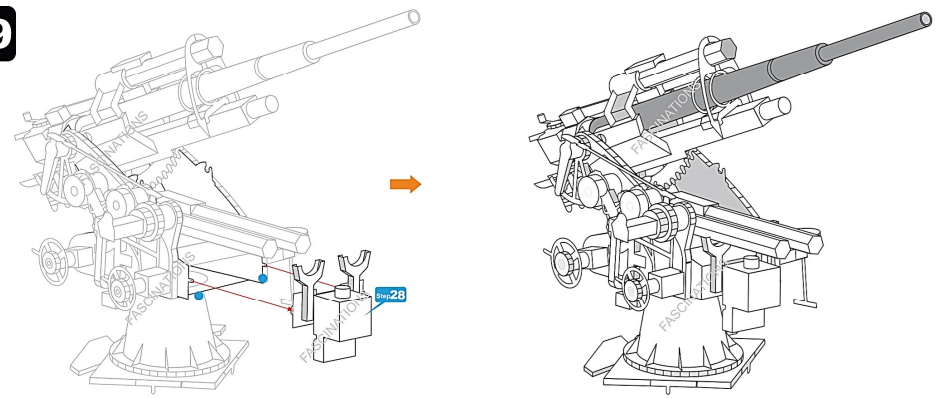

Step 30

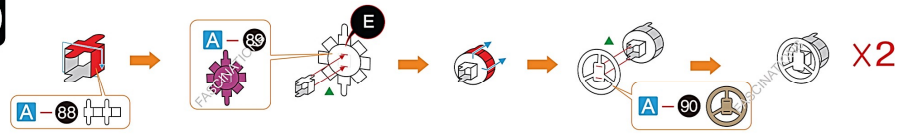

Step 31

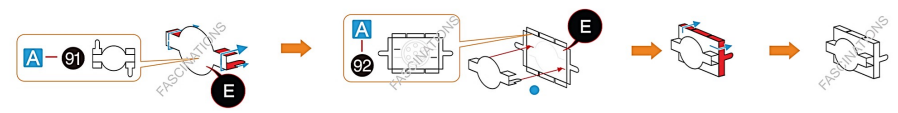

Step 32

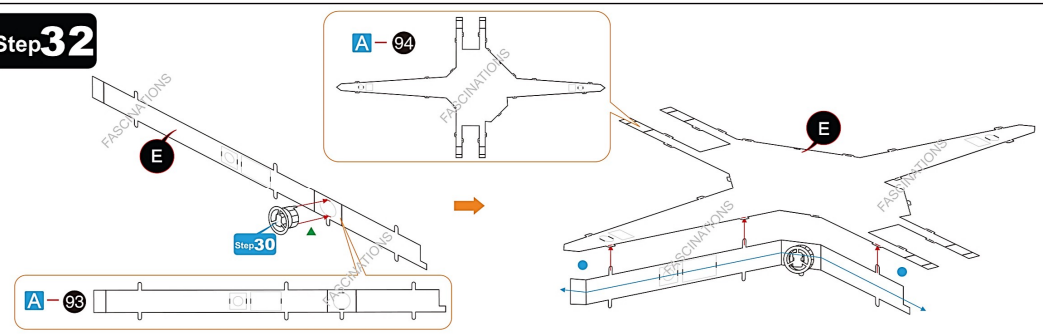

Step 33

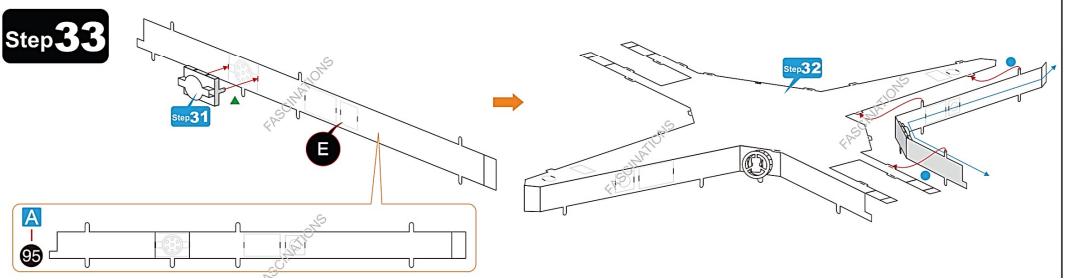

Step 34

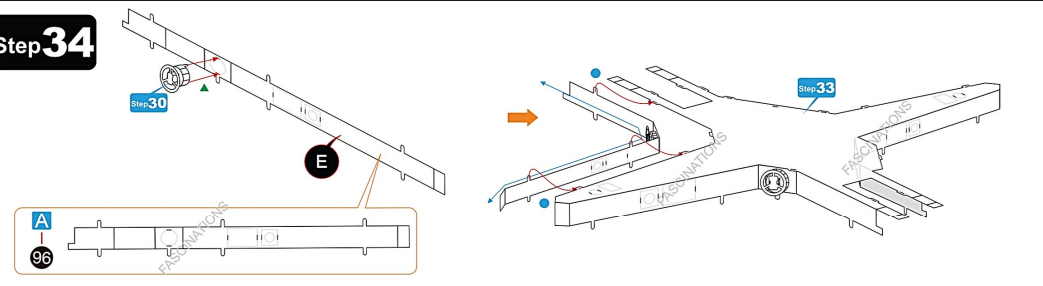

Step 35

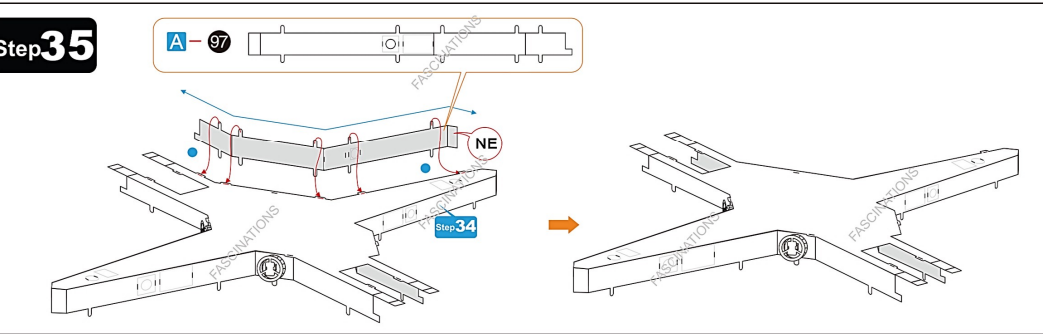

Step 36

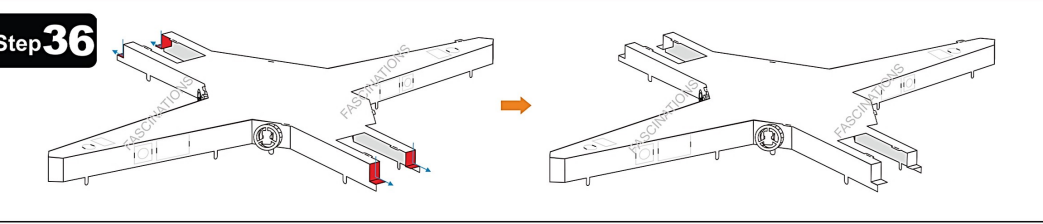

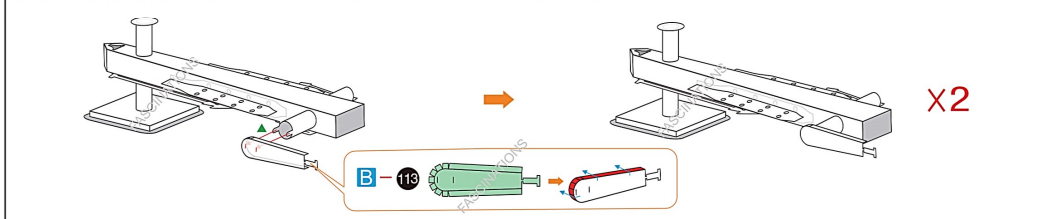
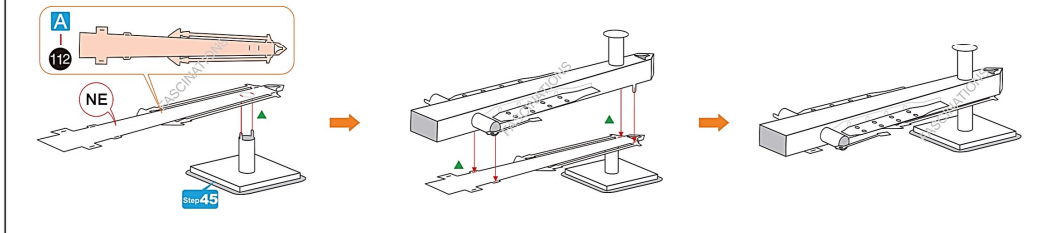
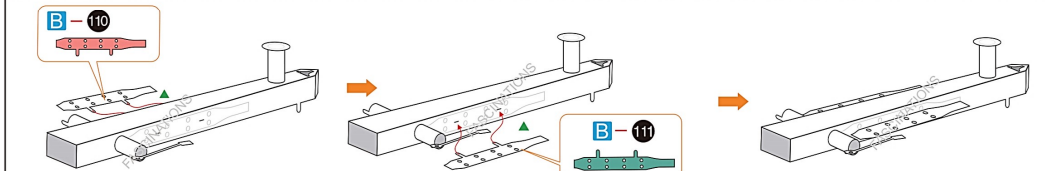
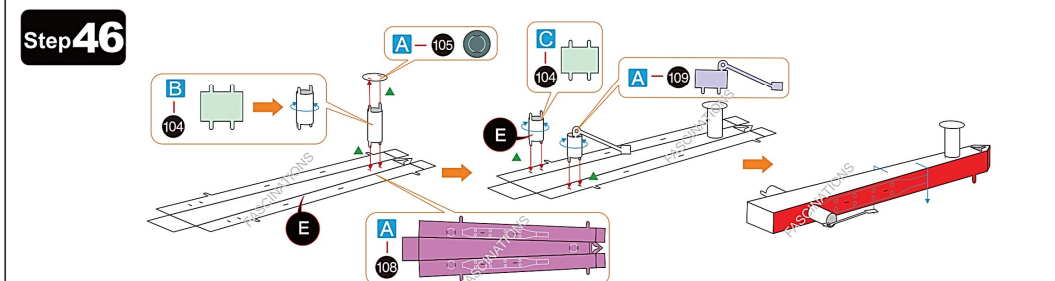
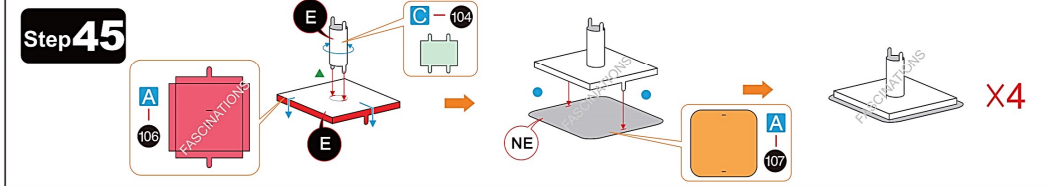
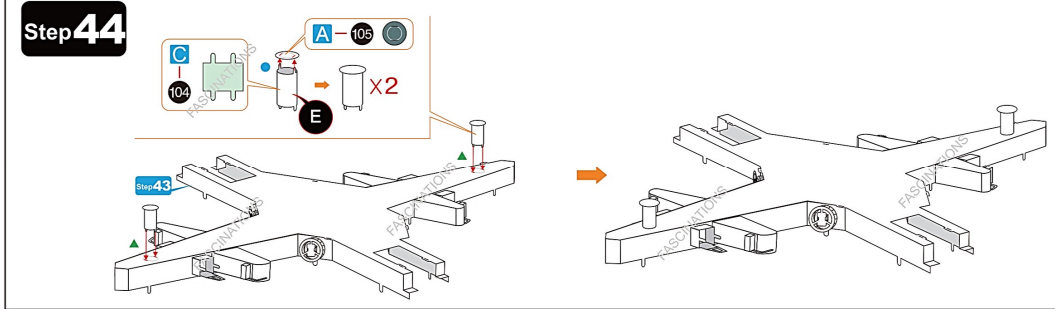
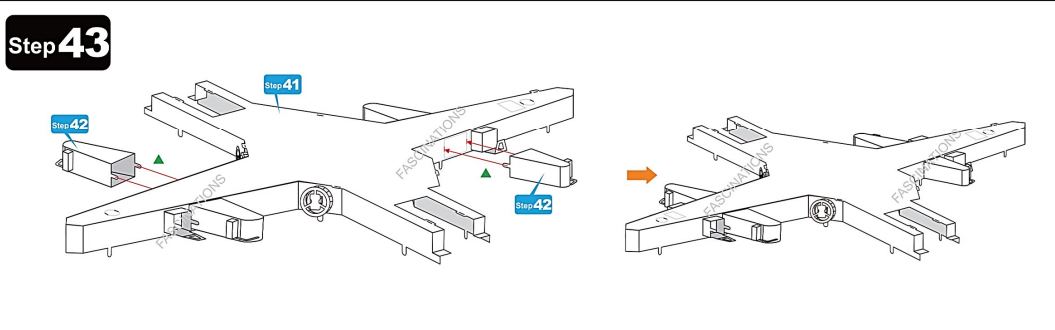
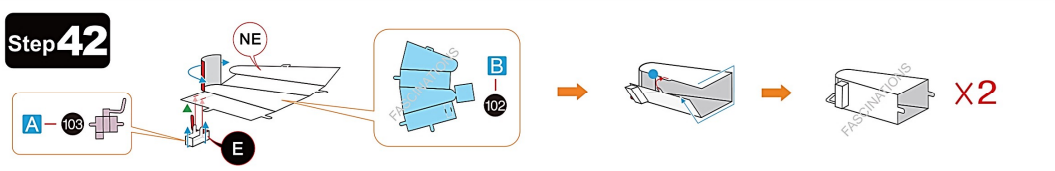
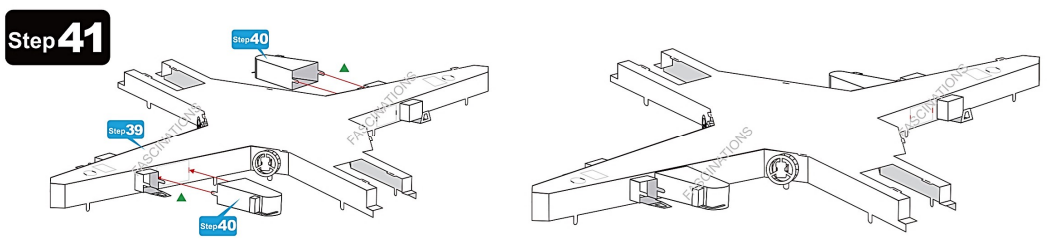
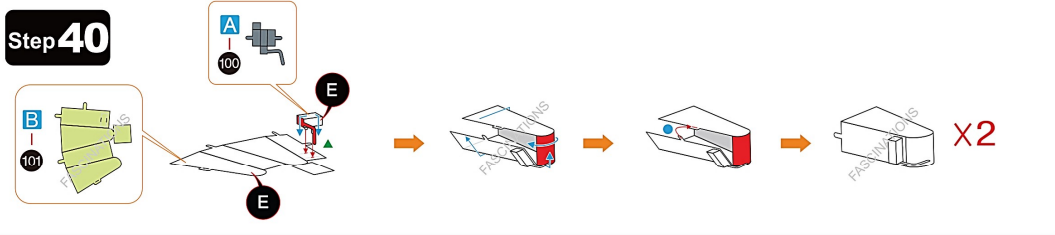
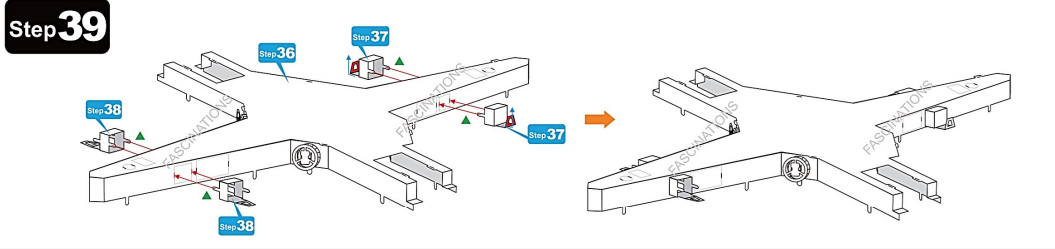
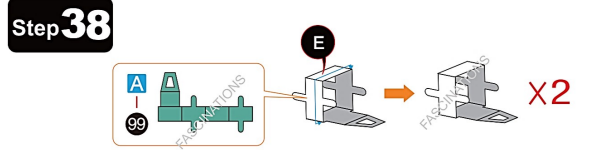
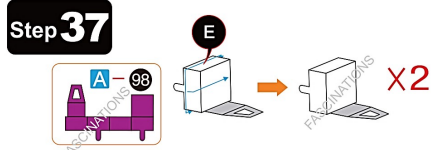

Step 47

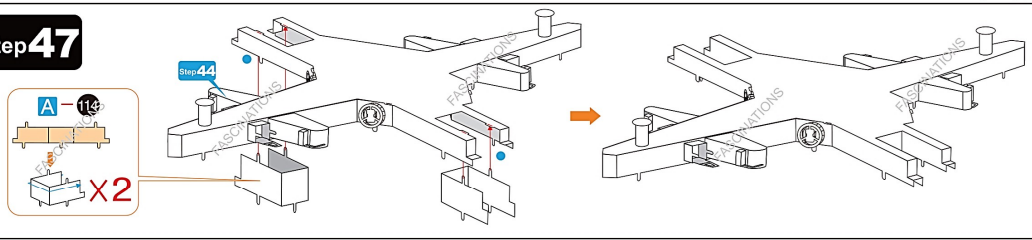

Step 48

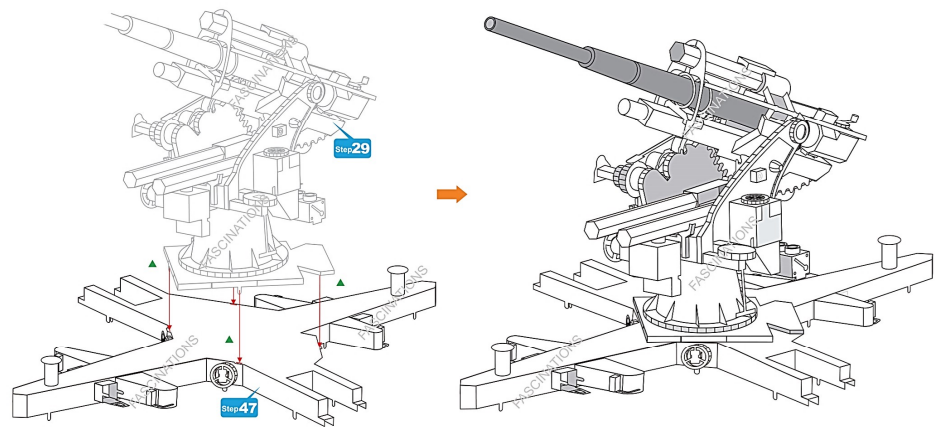

Step 49

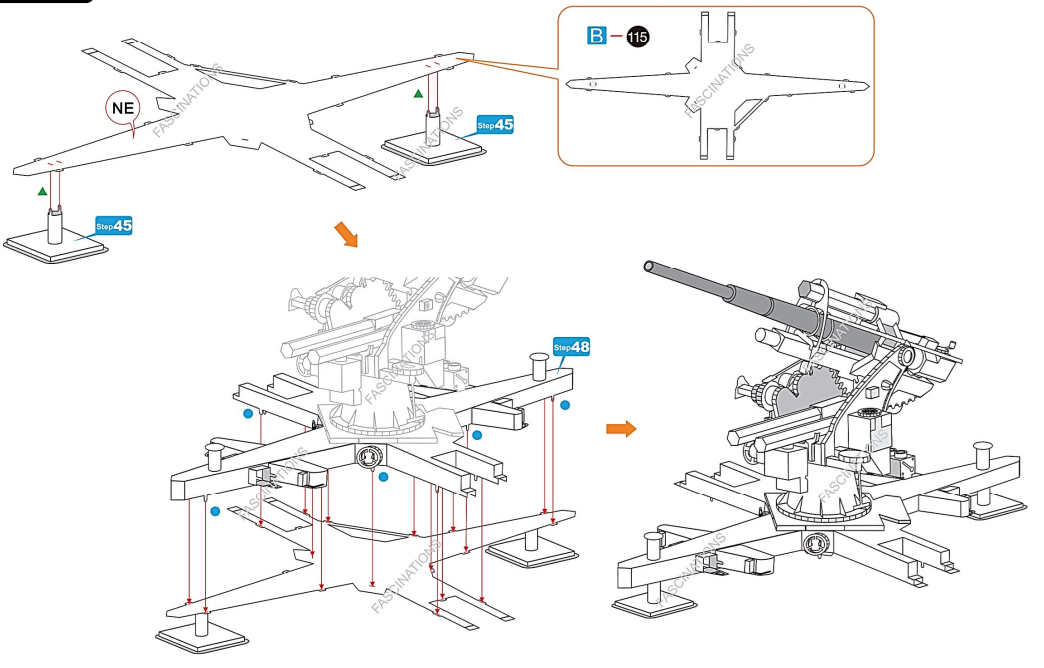

Step 50

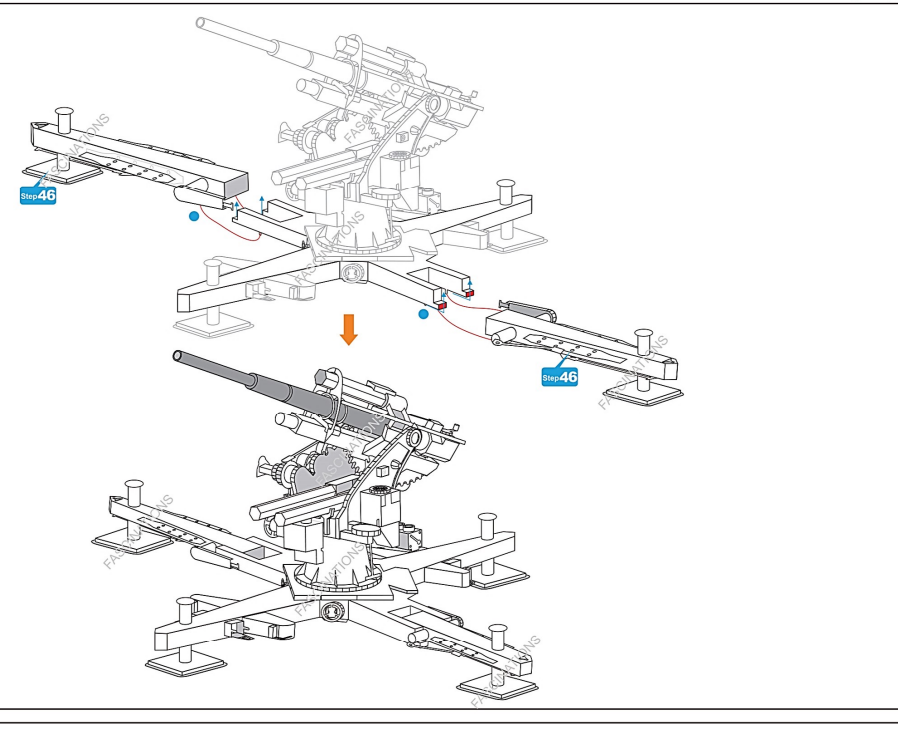

Step 51

