

P-40 WARHAWK
MMS213

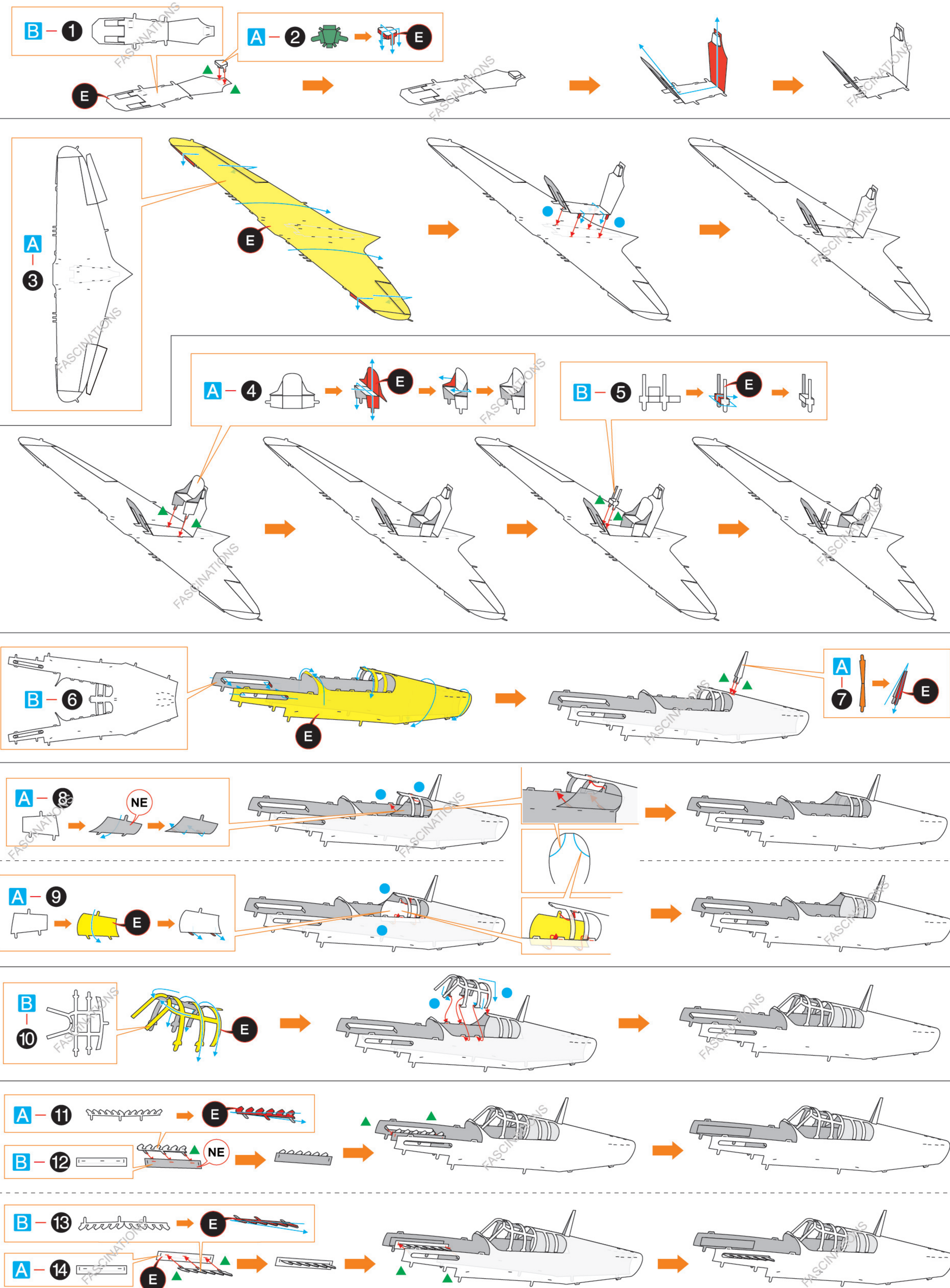

It is highly recommended that you visit www.metalearth.com/360/mms213 to see the completed model before assembling your own

Assembly Flow Chart



Insertion tabs are inserted and then folded

Insertion holes

Fold lines can be seen as shown here

Legends:

- E Engraved / Color side
- NE Non-engraved / Silver side
- Attention point
- Insert tab and bend 90 degrees
- ▲ Insert tab and twist 90 degrees

Assembly tip:
If needed, slightly twist tabs to hold parts together then untwist and bend them down for a nice finish

Recommended tools:

- Wire cutters: helpful for taking parts from the metal sheets.
- Tweezers or needle nose pliers: helpful for folding parts, bending and twisting tabs.

Metal sheets

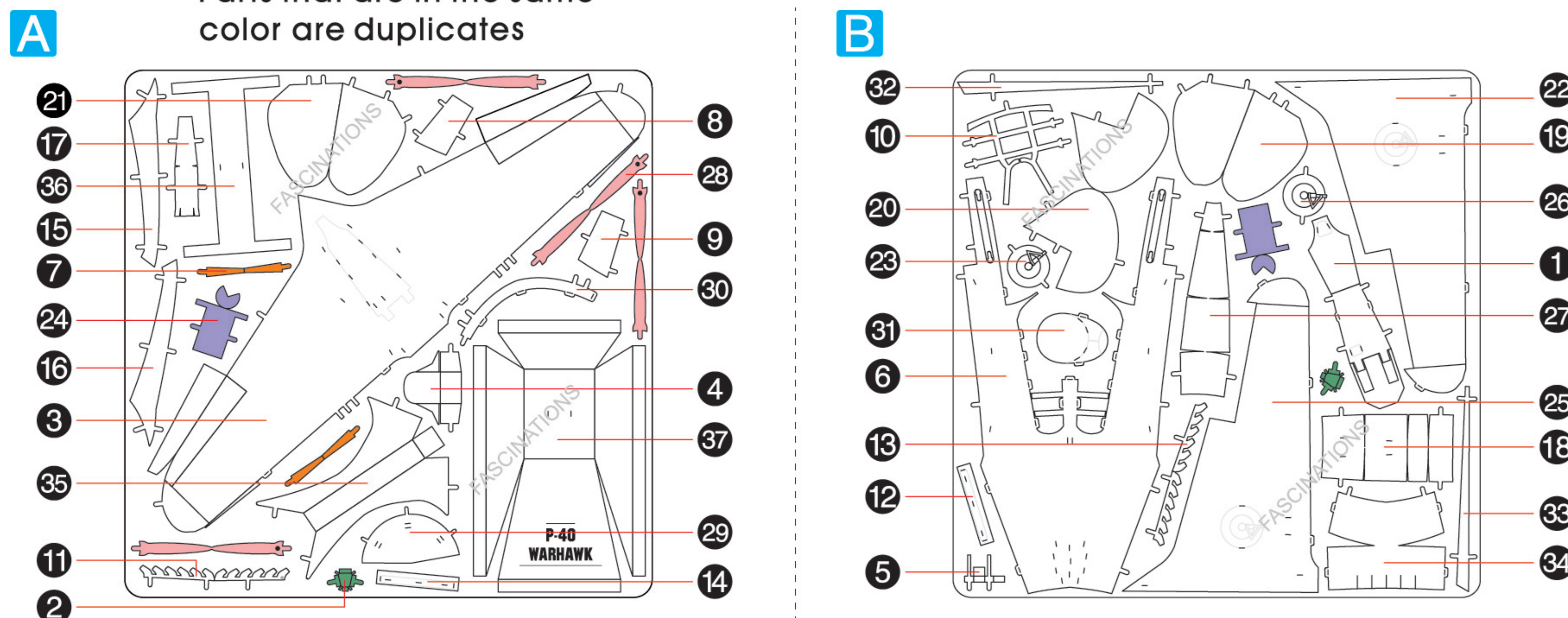

In order to avoid possible injury from sharp edges, please carefully discard the metal sheets after parts have been removed

Go to www.metalearth.com/360/mms213 to see the zoomable PDF version of this instruction sheet

