

P-47 THUNDERBOLT ME1002



It is highly recommended that you visit www.metalearth.com/360/ME1002 to see the completed model before assembling your own

ASSEMBLY FLOW CHART

Step 1

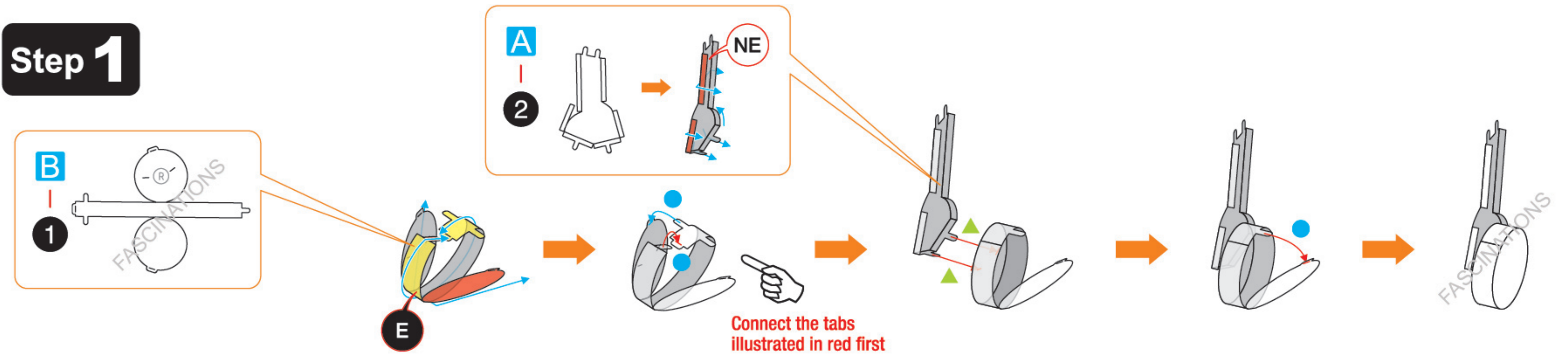

Step 2

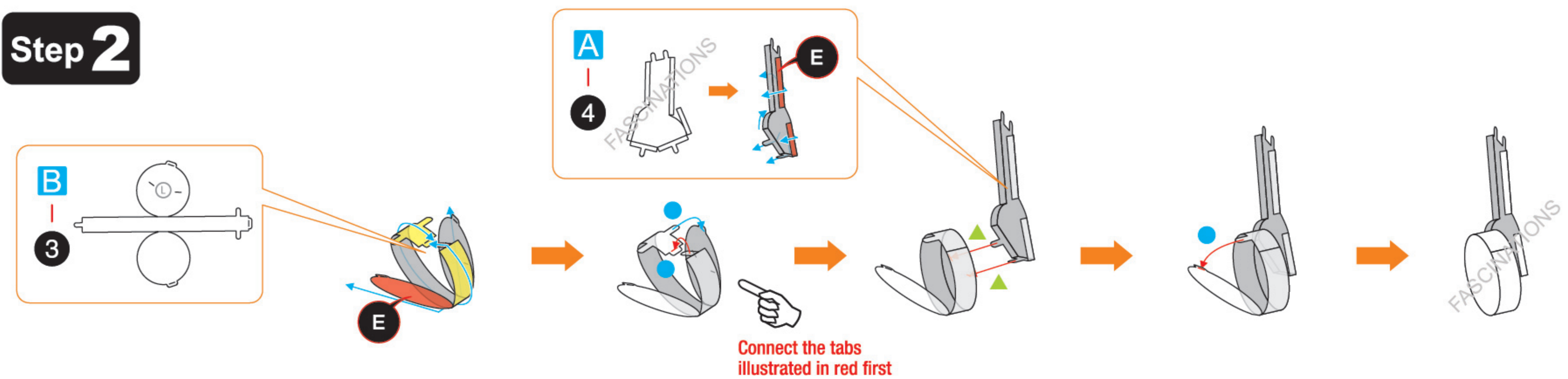

Step 3

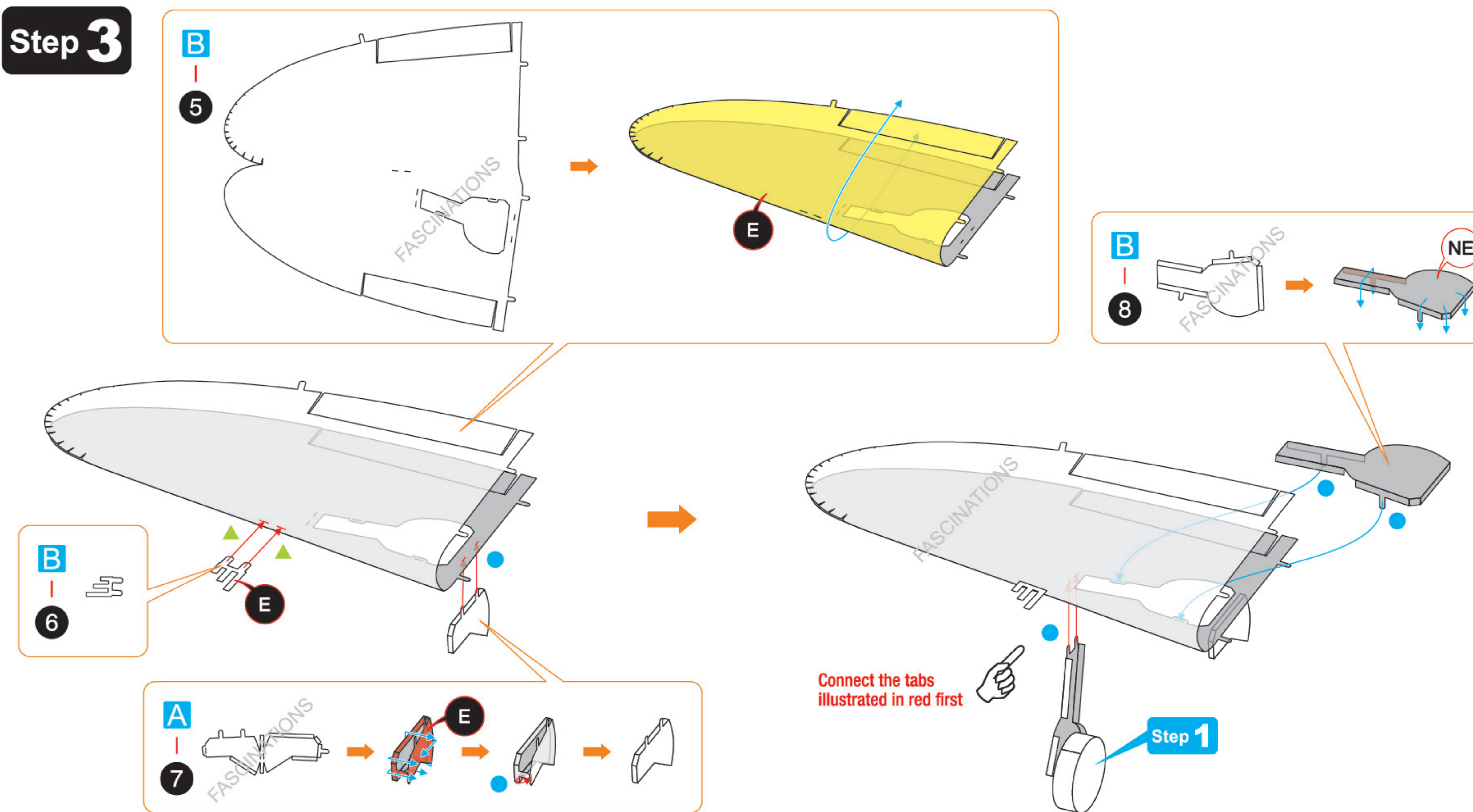

TO CREATE THE BEST CONNECTIONS

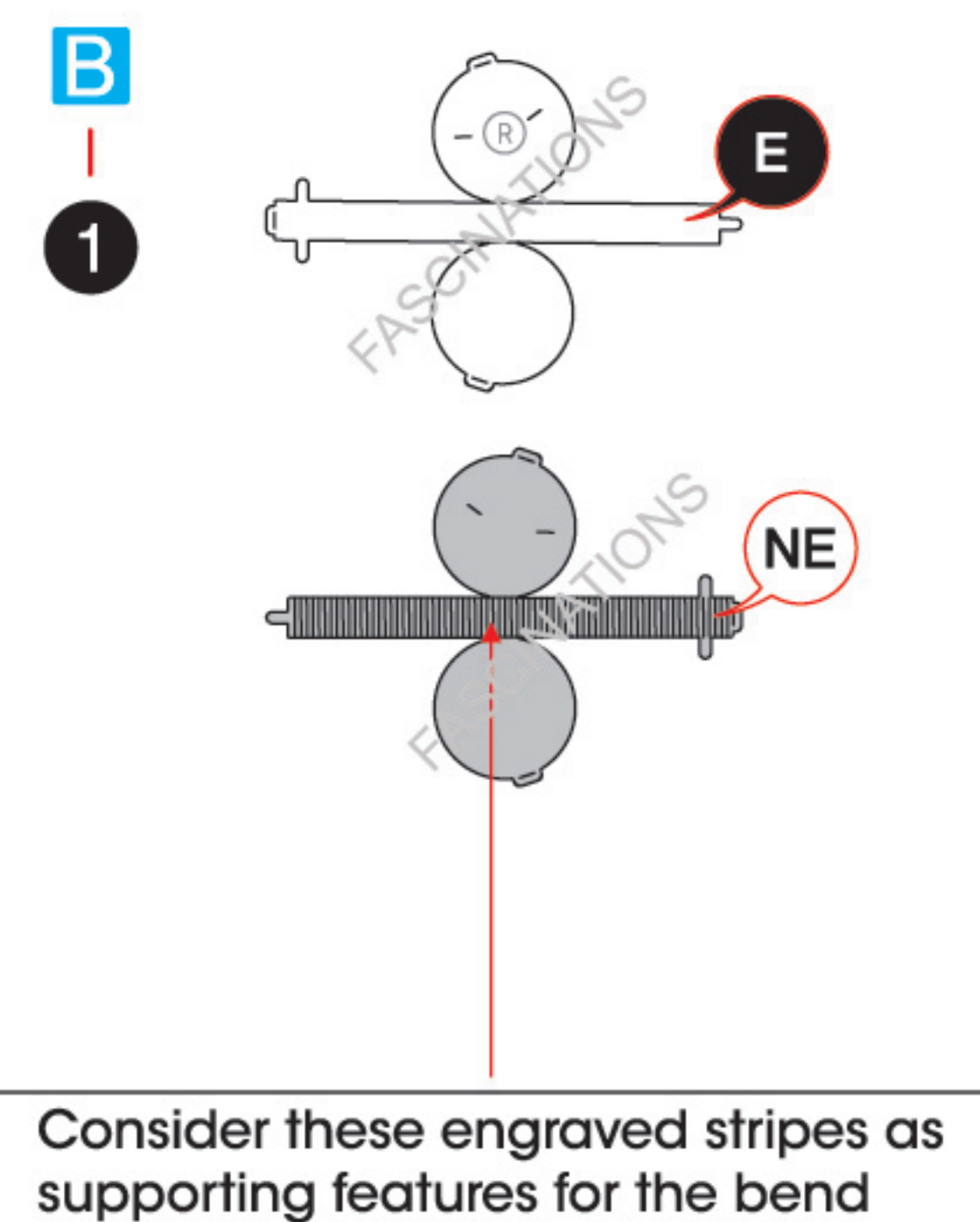

Legends:

- Engraved/ Color side
- Non - engraved/ Silver side
- Attention point
- Insert tab and bend 90 degrees
- Insert tab and twist 90 degrees

Assembly tip:

If needed, slightly twist tabs to hold parts together then untwist and bend them down for a nice finish.

- Yellow areas should be curled
- Red areas should be folded

Recommended tools:

- Wire cutters: helpful for taking parts from the metal sheets.



- Tweezers or needle nose pliers: helpful for folding parts, bending and twisting tabs.

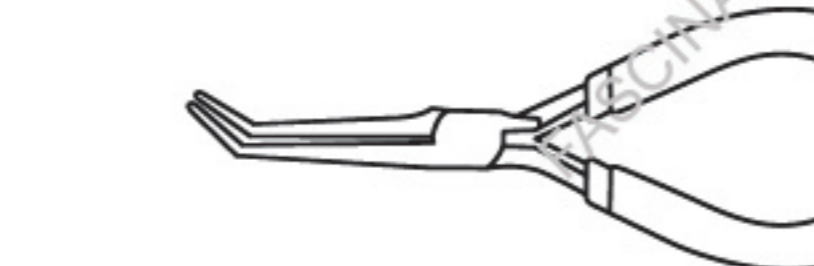
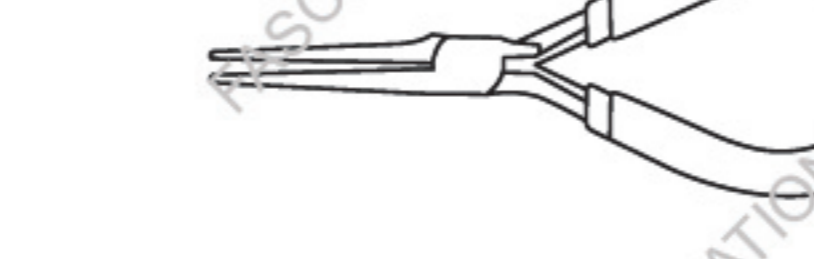

METAL SHEETS

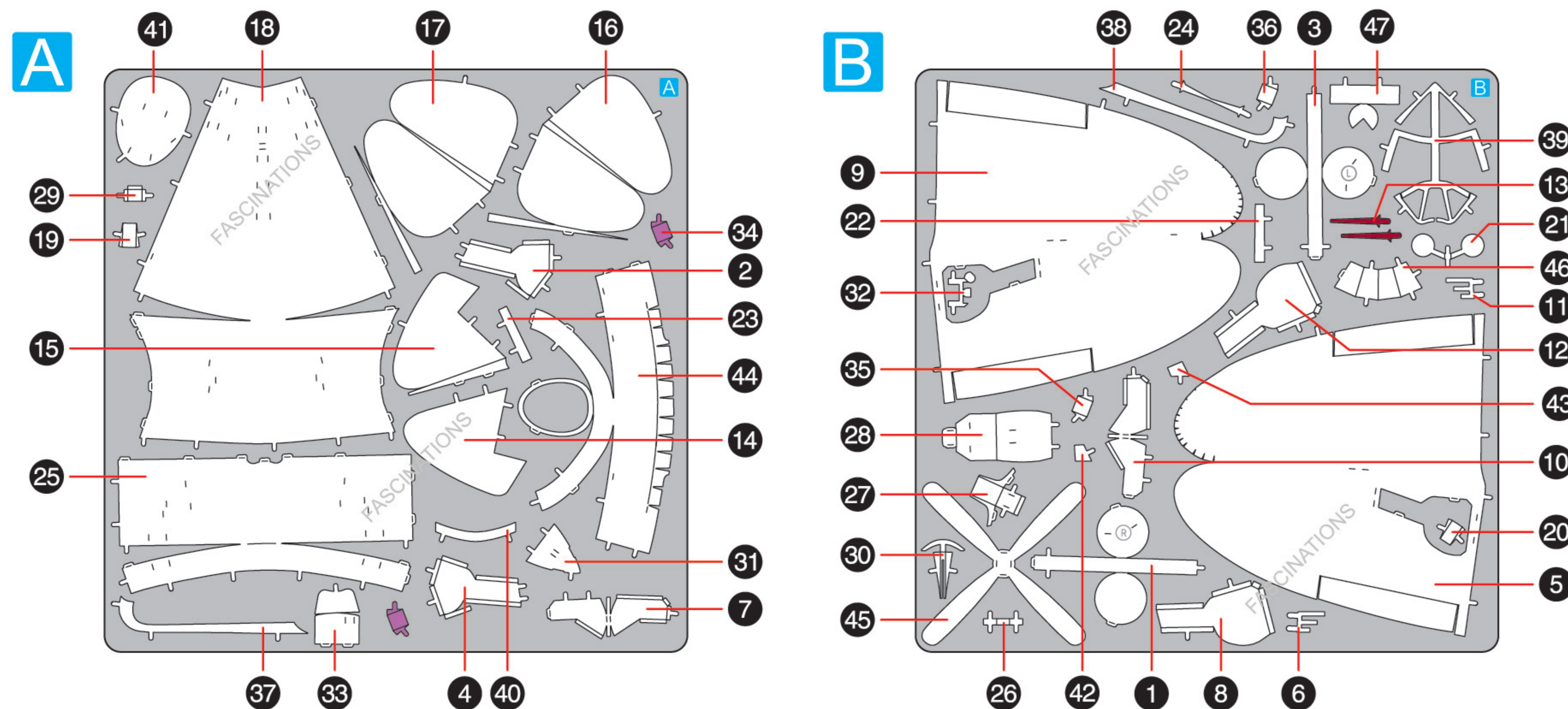

In order to avoid possible injury from sharp edges, please carefully discard the metal sheets after parts have been removed.

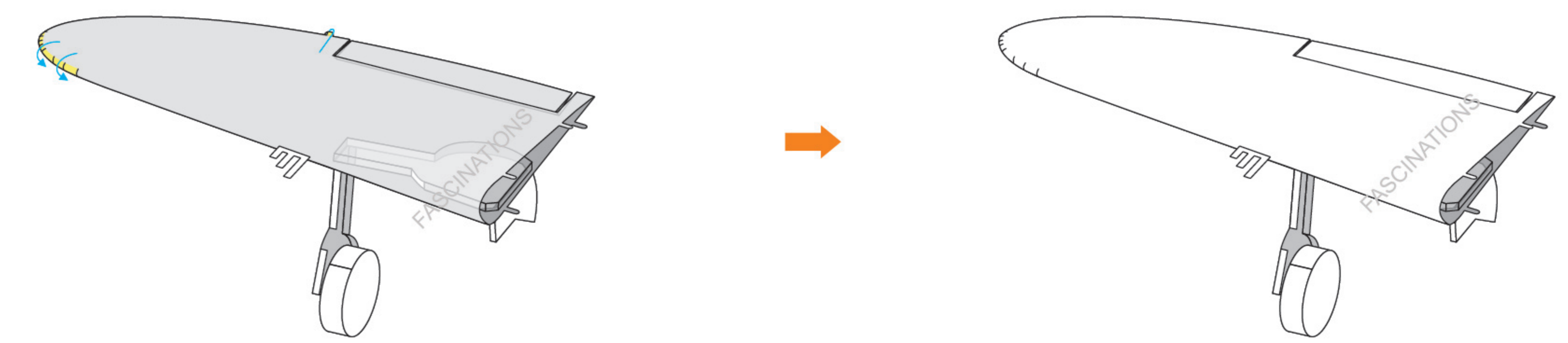

Step 4

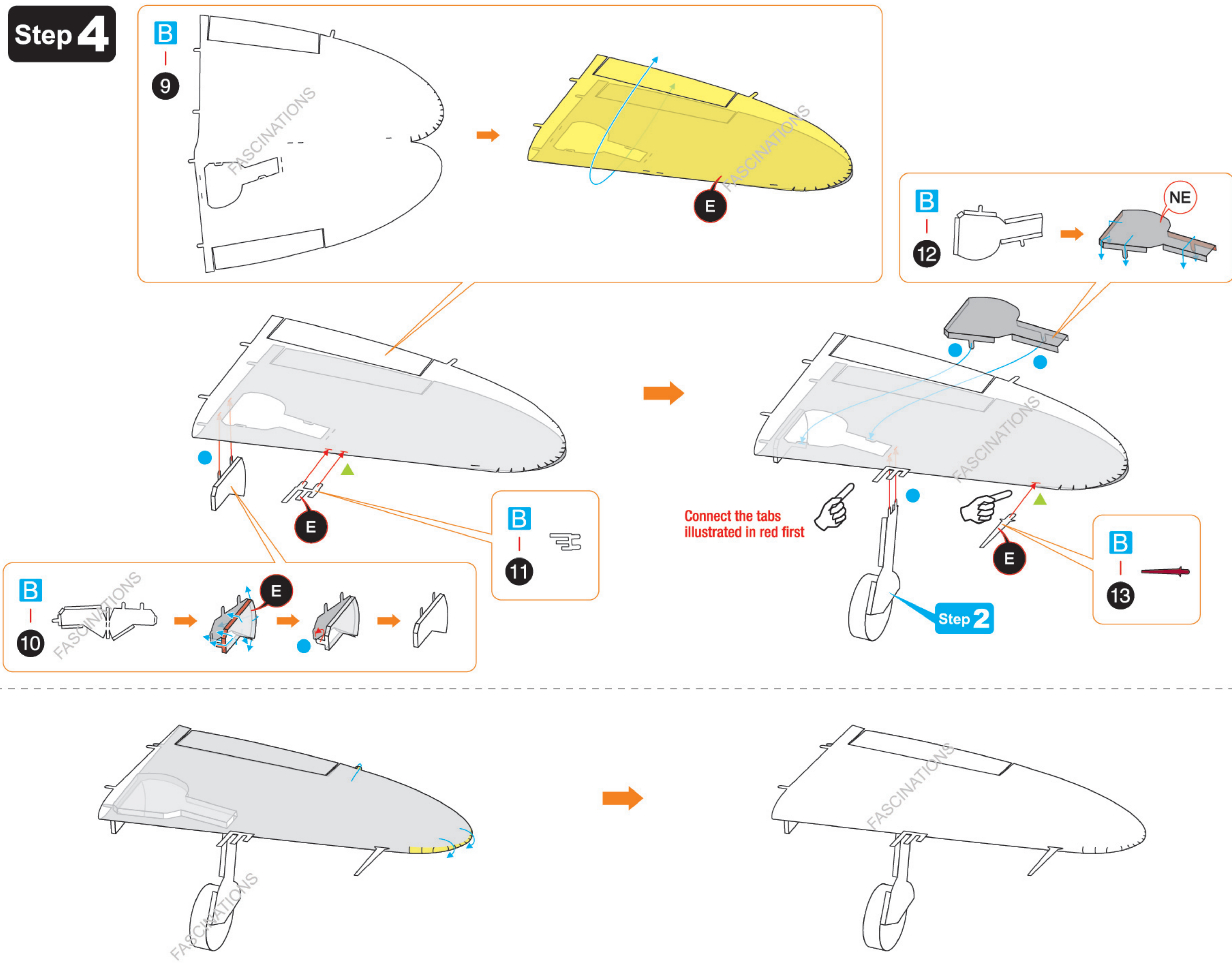

Step 5

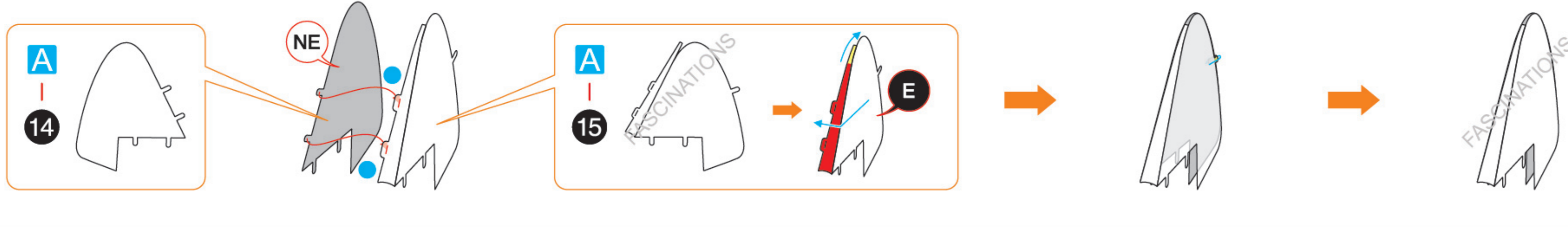

Step 6

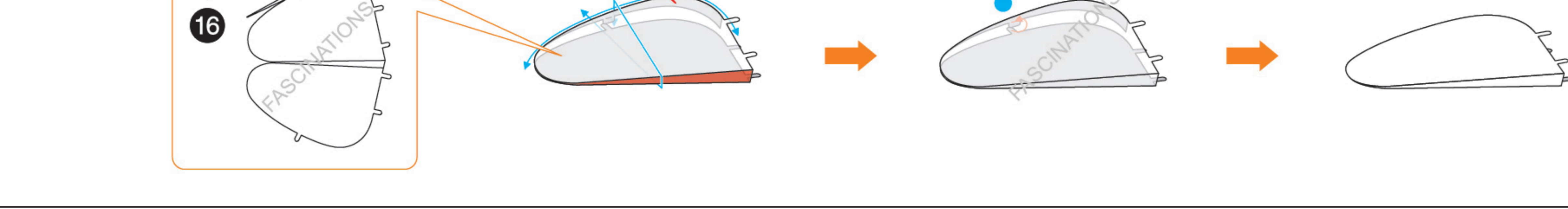

Step 7

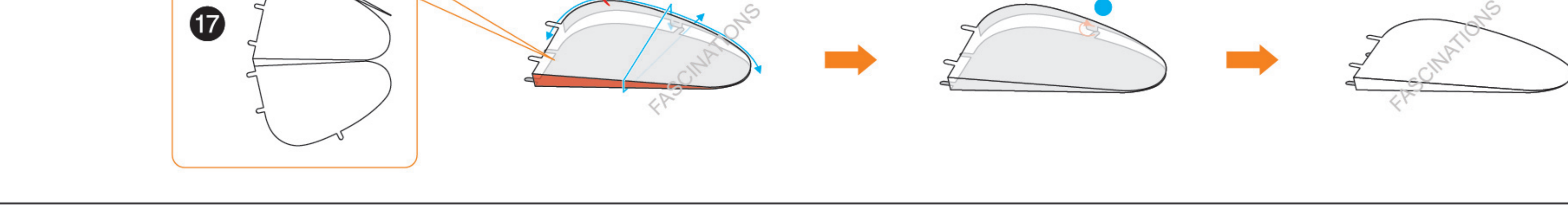

Step 8

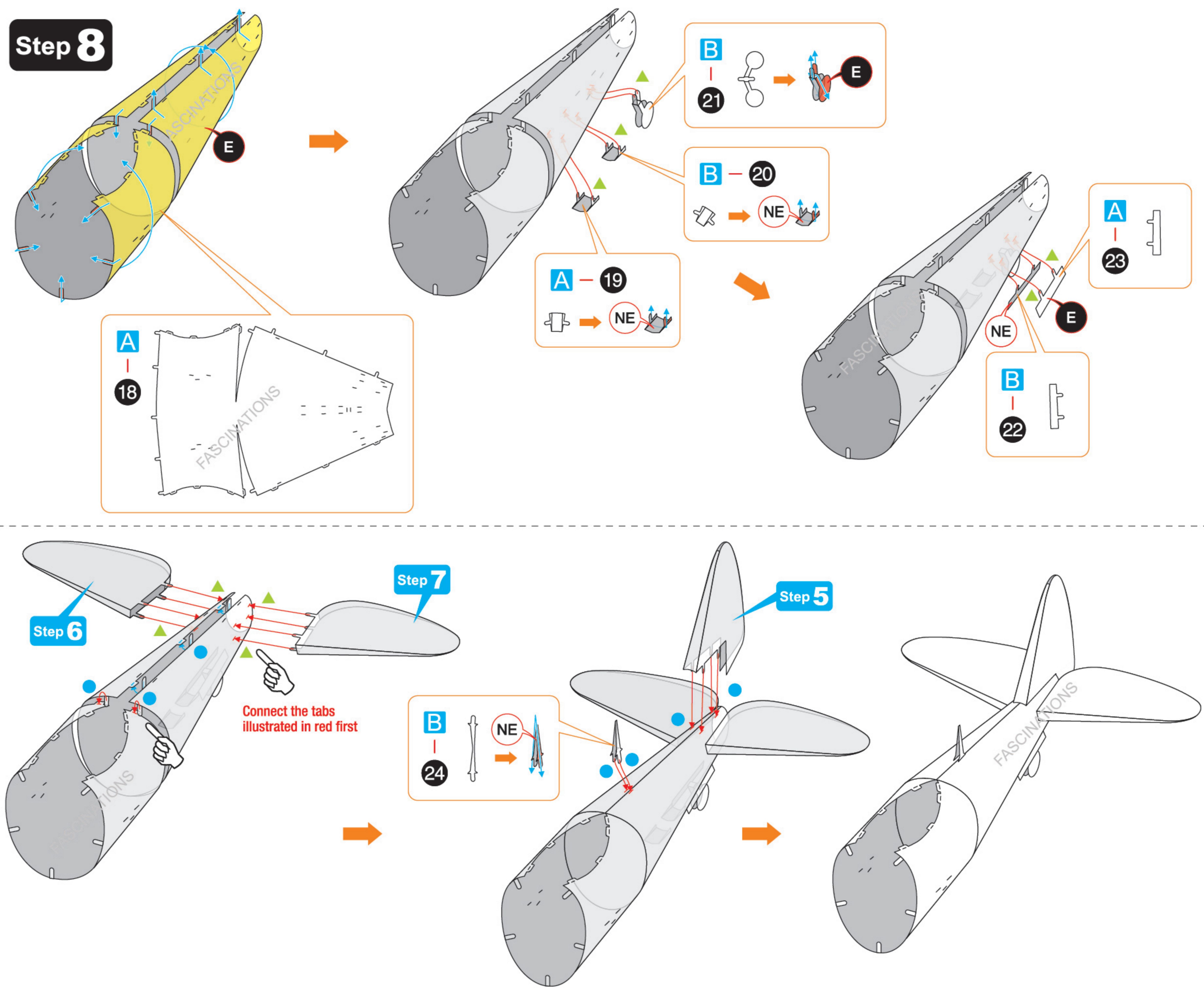

Step 9

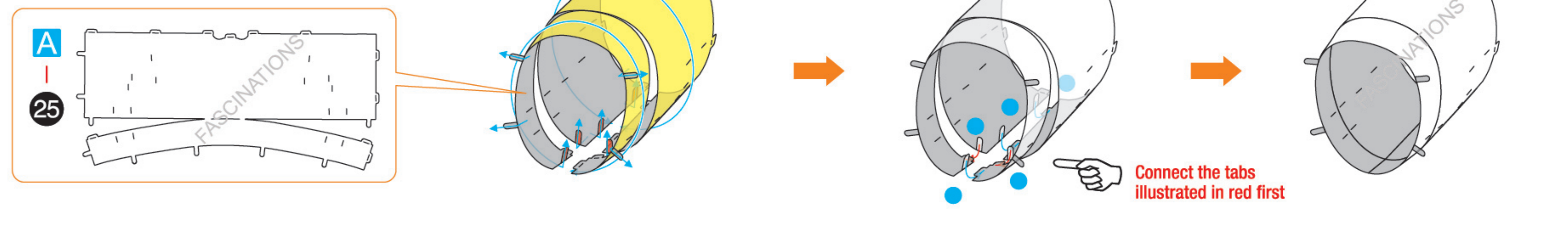

Step 10

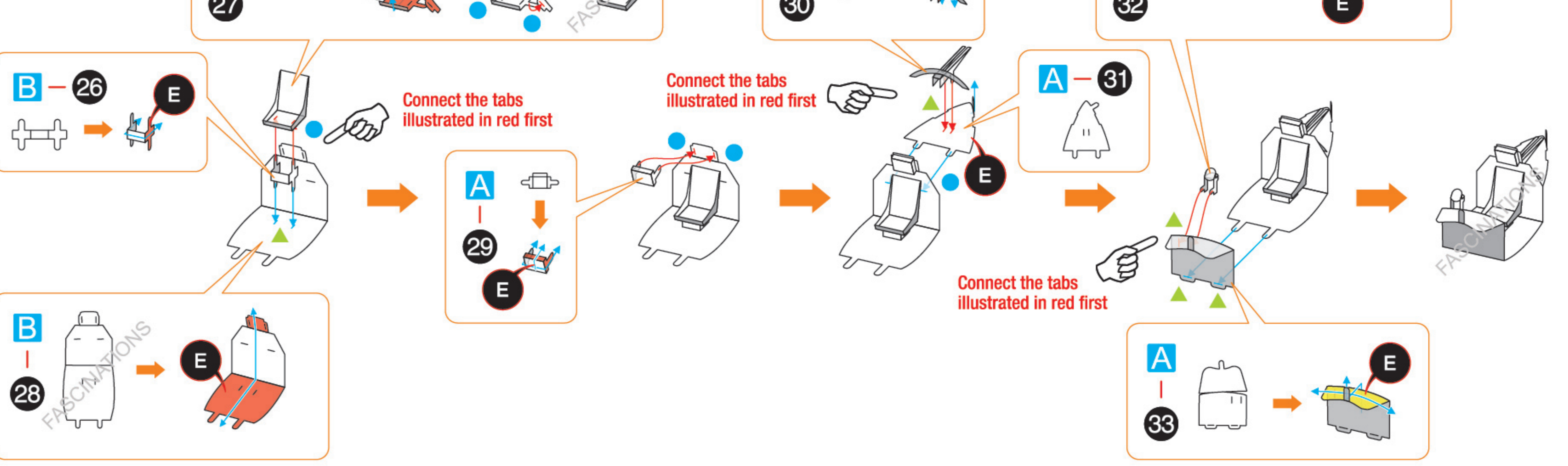

Step 11

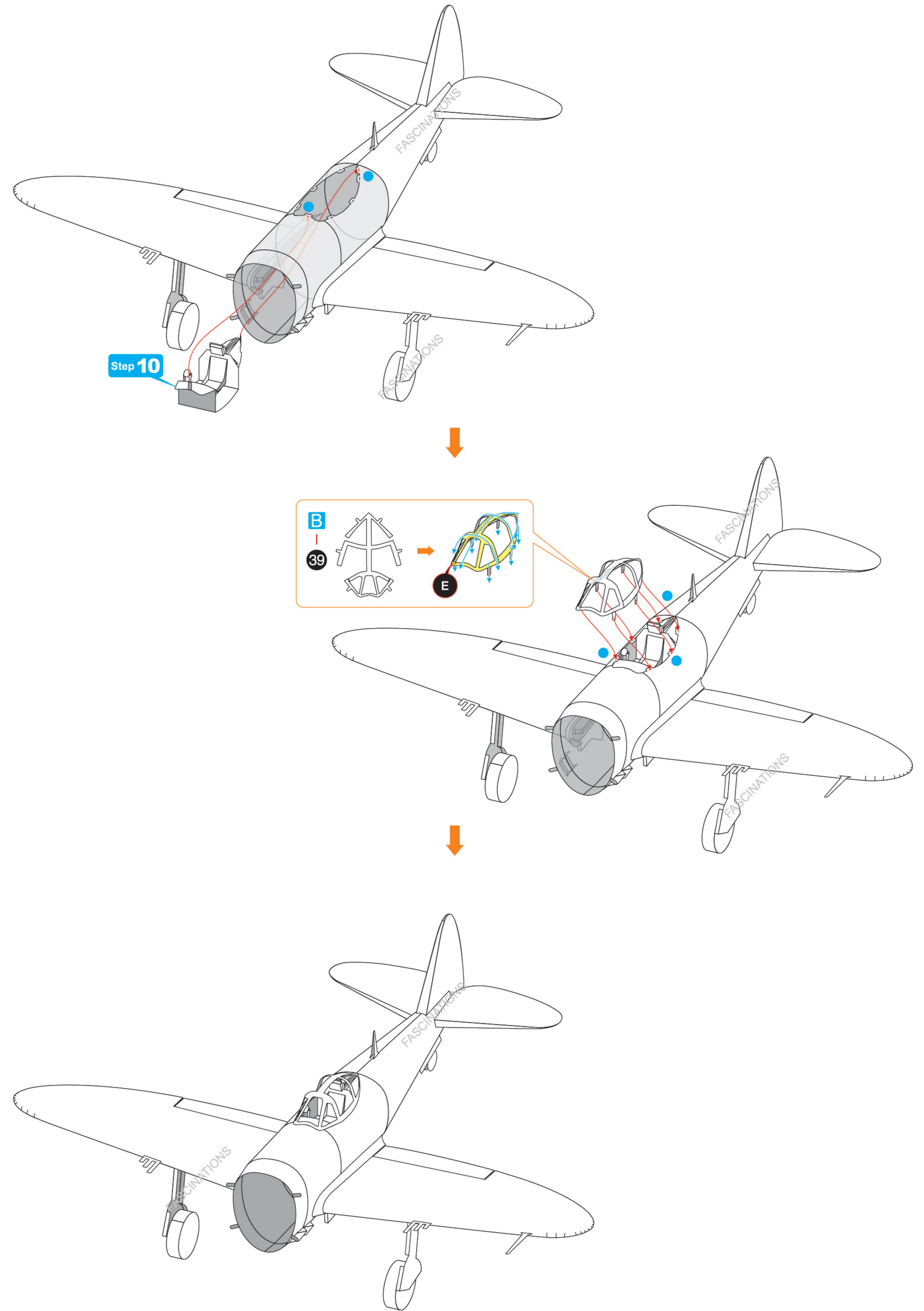
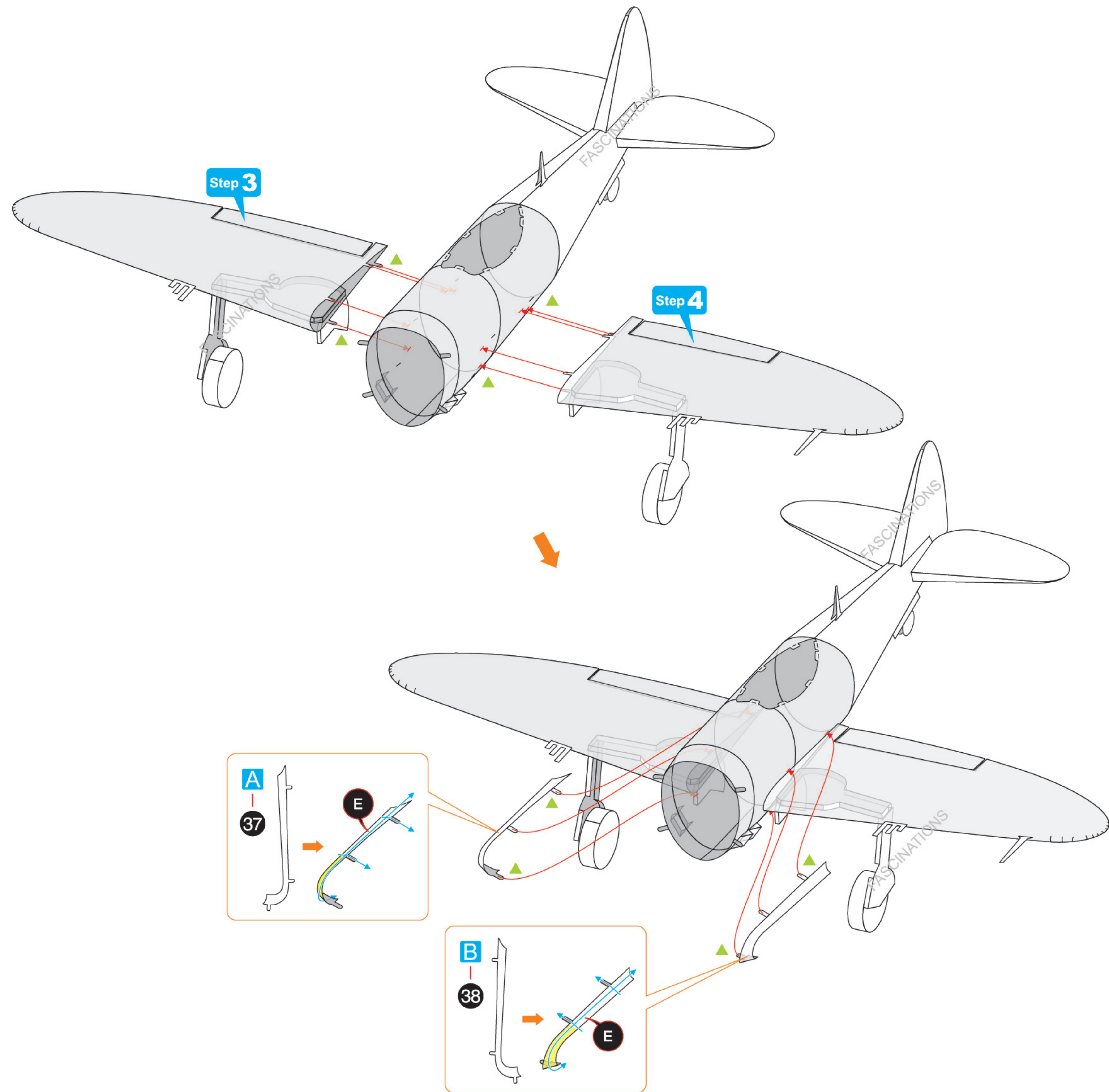
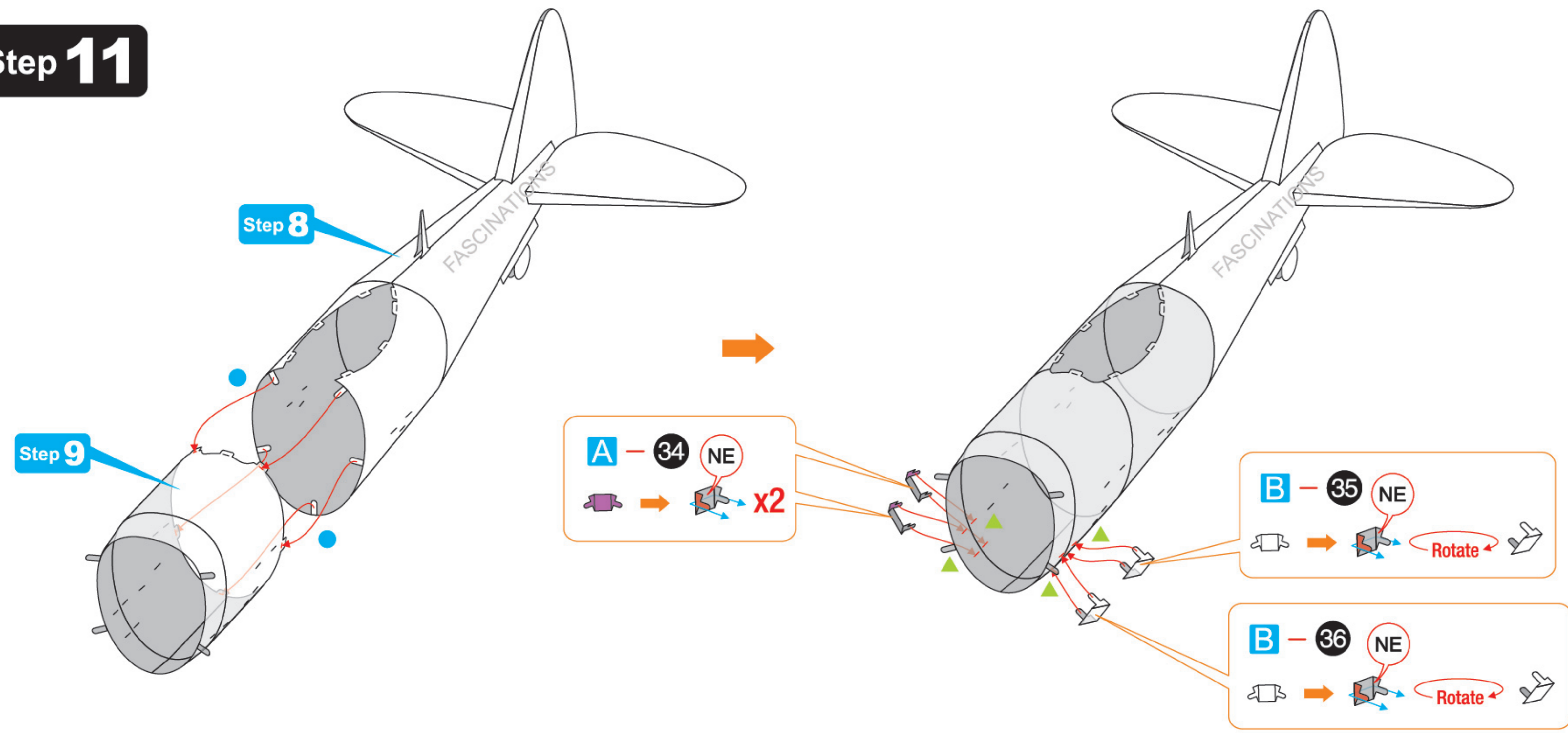

Step 12

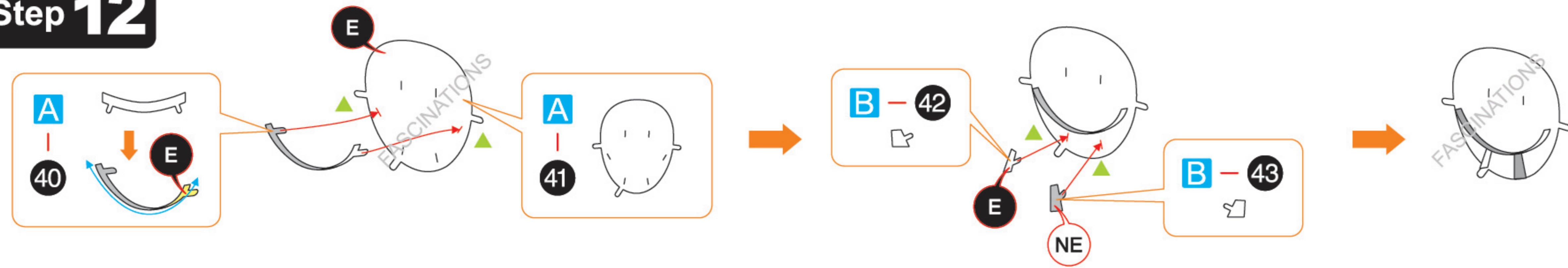

Step 13

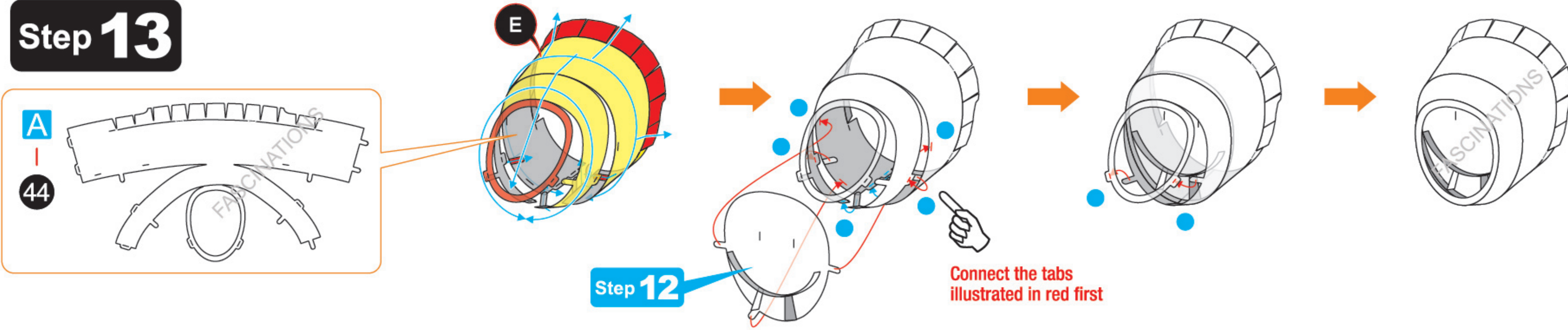

Step 14

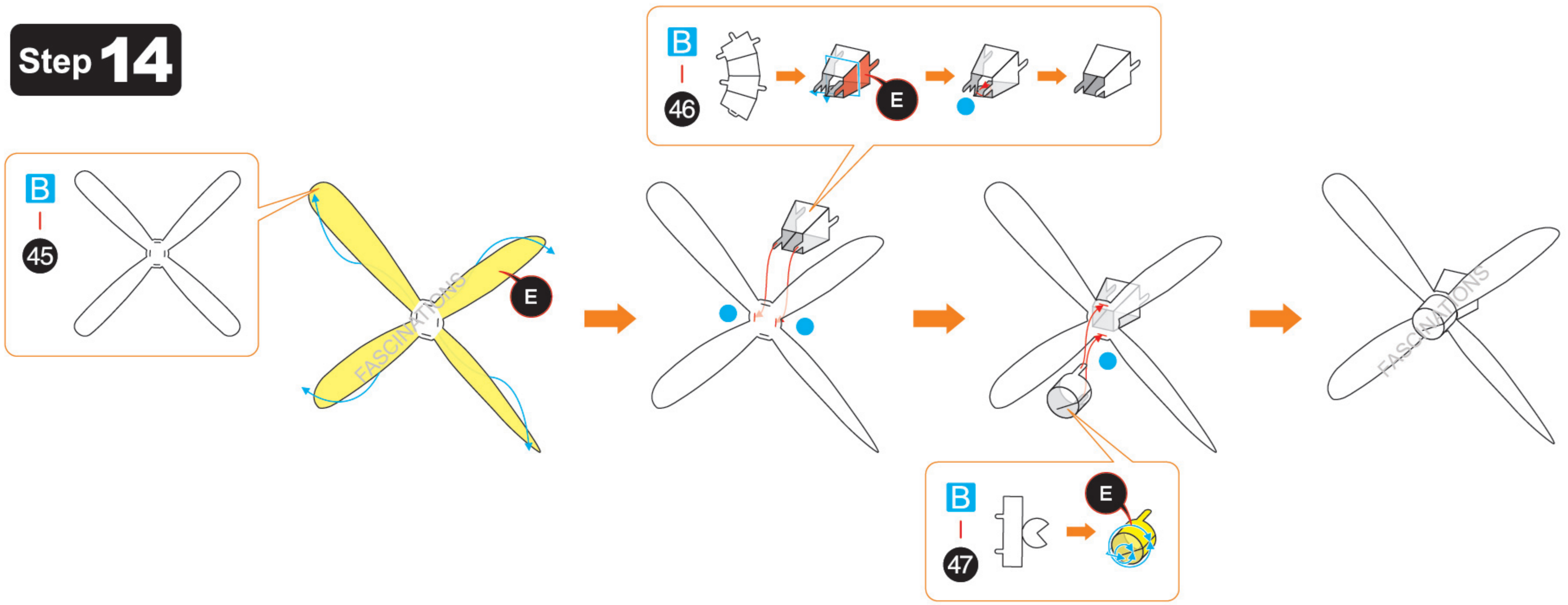

Step 15

