

MITSUBISHI ZERO ME1012

It is highly recommended that you visit www.metalearth.com/360/ME1012 to see the completed model before assembling your own

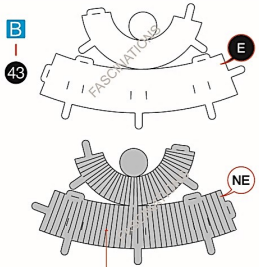

TO CREATE THE BEST CONNECTIONS



Consider these engraved stripes as supporting features for the bend

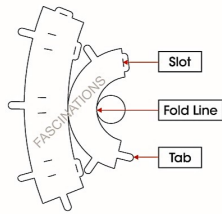

Legends:

- E** Engraved/ Color side
- NE** Non - engraved/ Silver side
- Attention point
- Insert tab and bend 90 degrees
- Insert tab and twist 90 degrees

Assembly tip:

If needed, slightly twist tabs to hold parts together then untwist and bend them down for a nice finish.

- Yellow areas should be curled
- Red areas should be folded

Recommended tools:

- Wire cutters: helpful for taking parts from the metal sheets.



- Tweezers or needle nose pliers: helpful for folding parts, bending and twisting tabs.

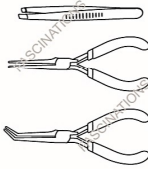

METAL SHEETS

Parts with same color are duplicates

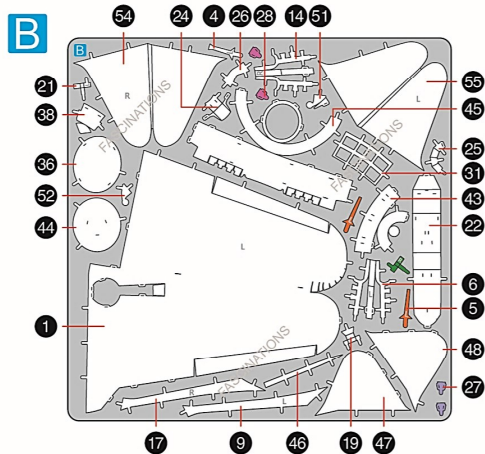
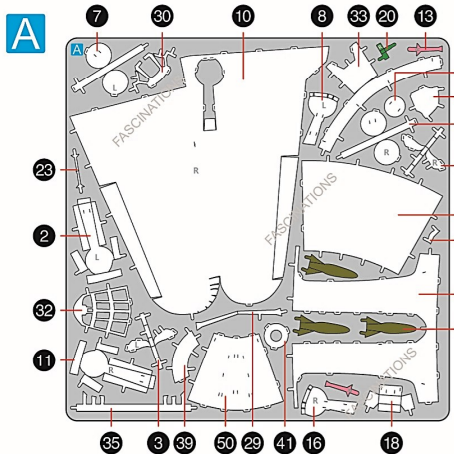

In order to avoid possible injury from sharp edges, please carefully discard the metal sheets after parts have been removed.

ASSEMBLY FLOW CHART

Step 1

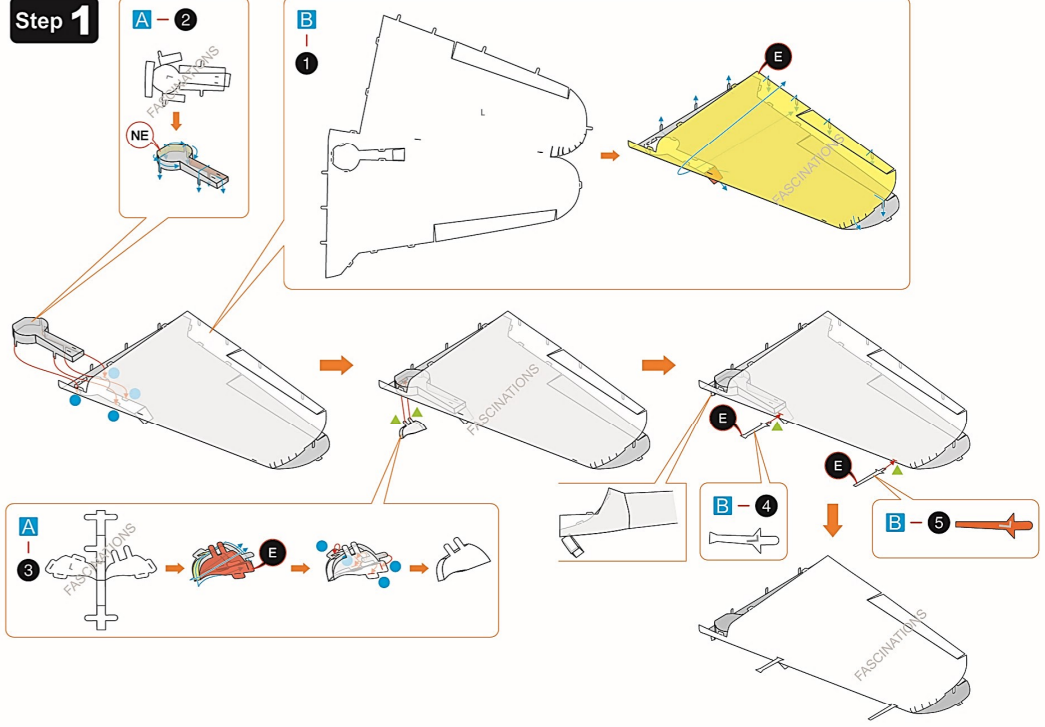

Step 2

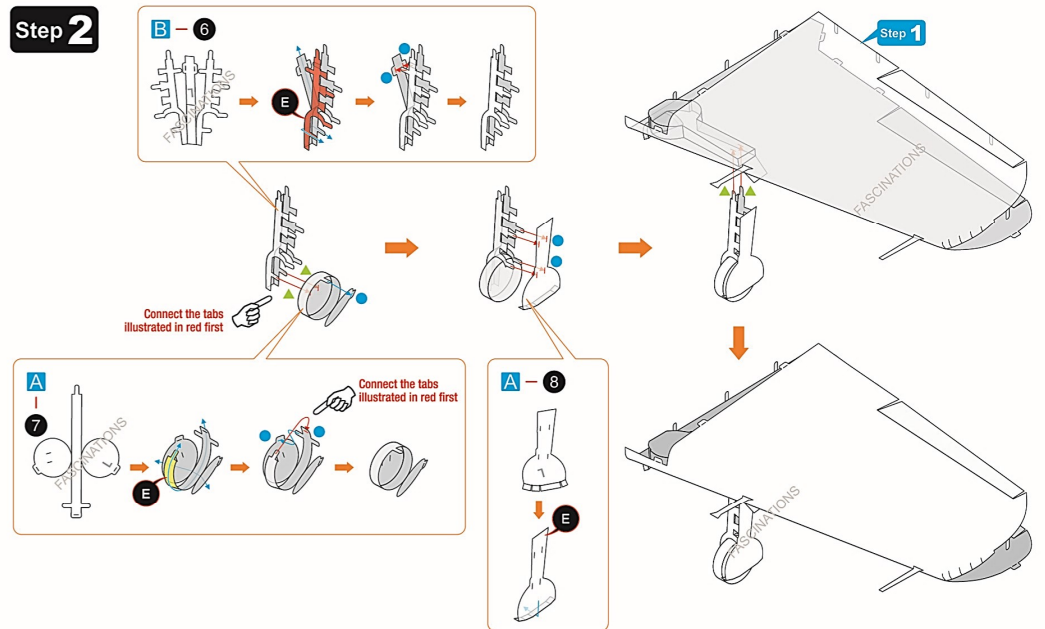

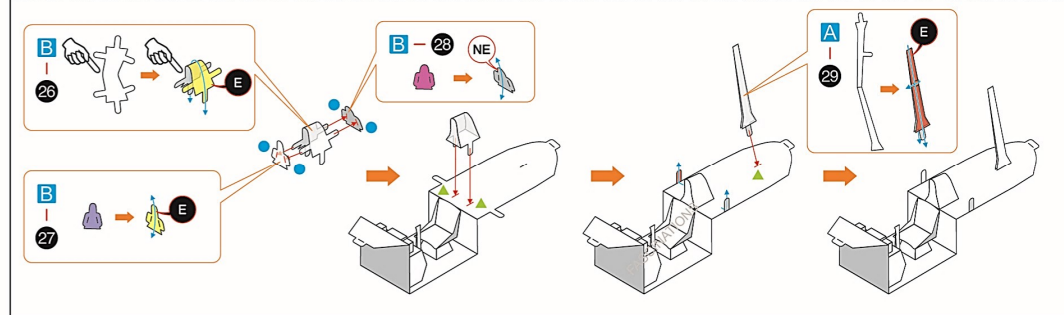
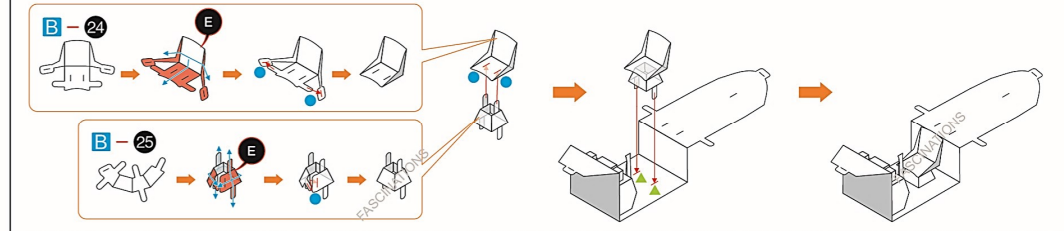
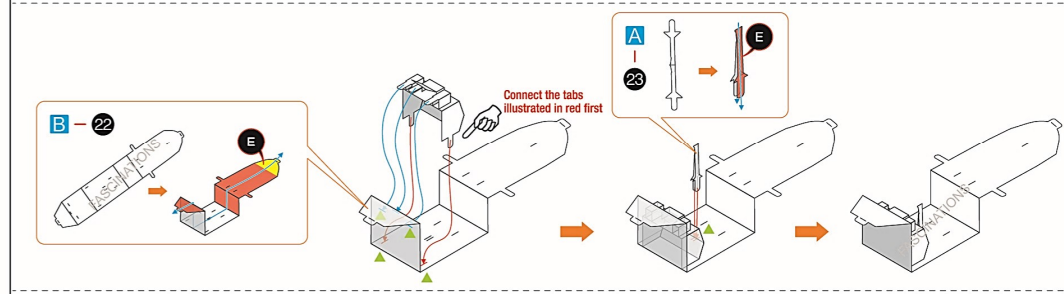
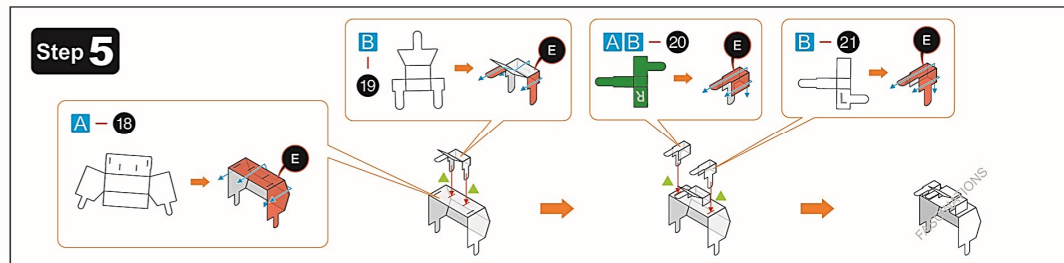
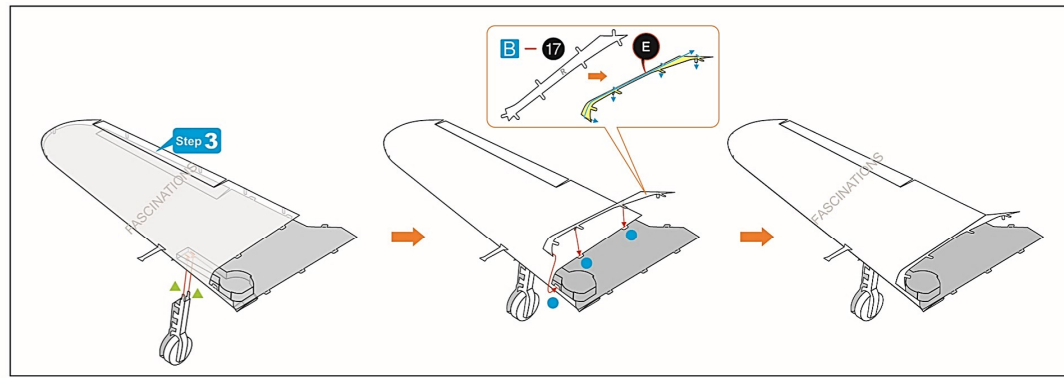
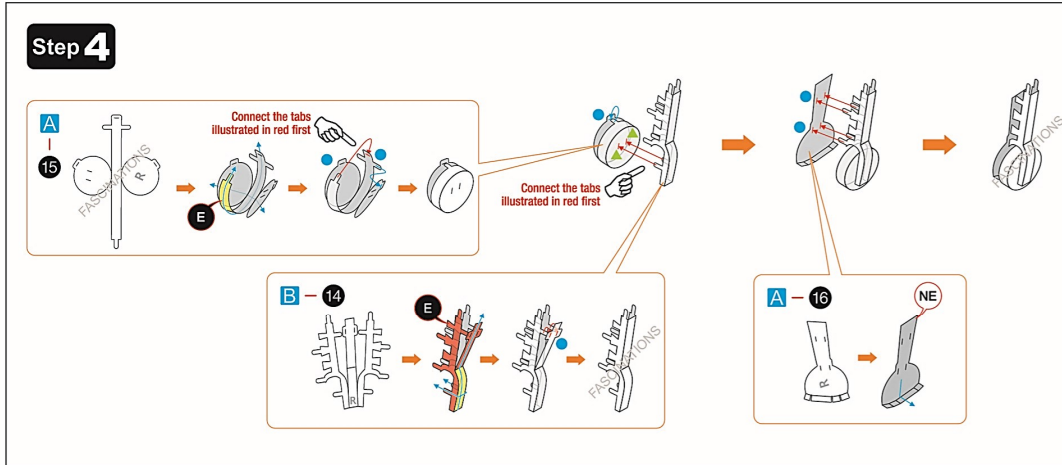
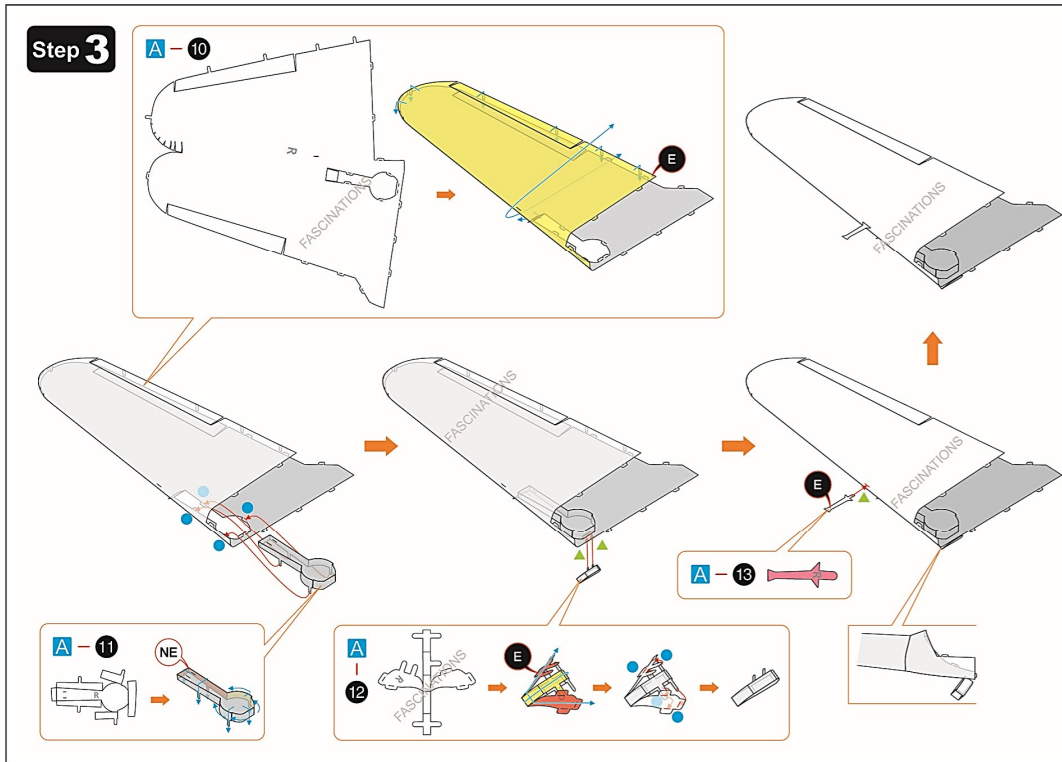
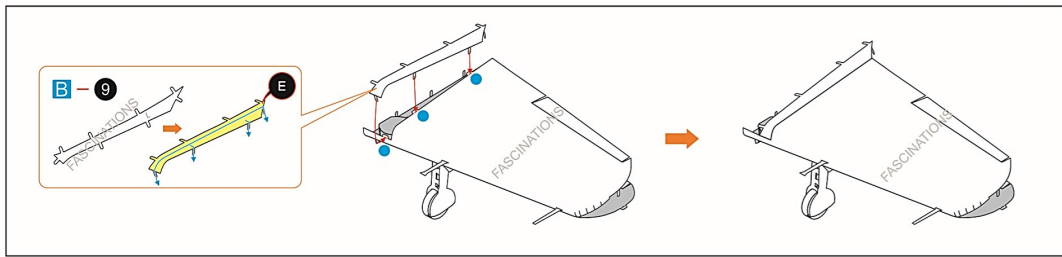

Step 6

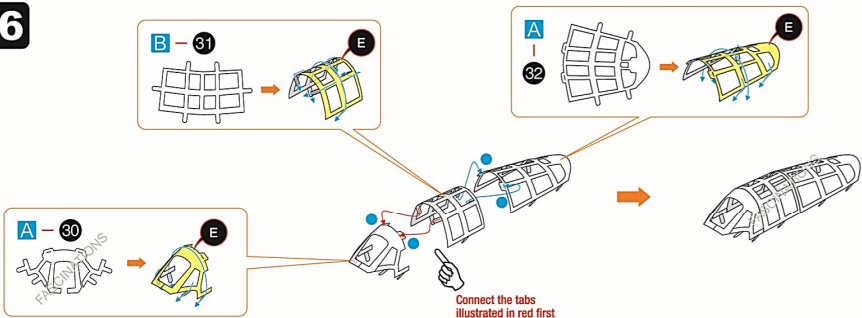

Step 7

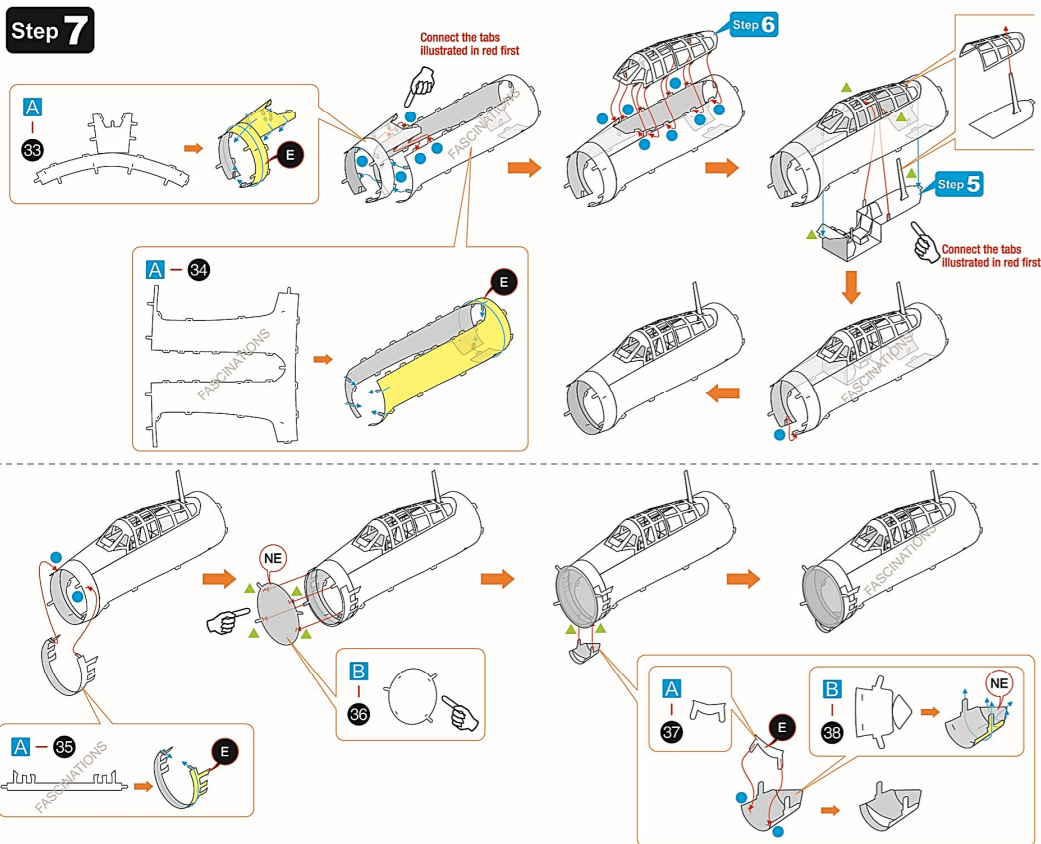

Step 8

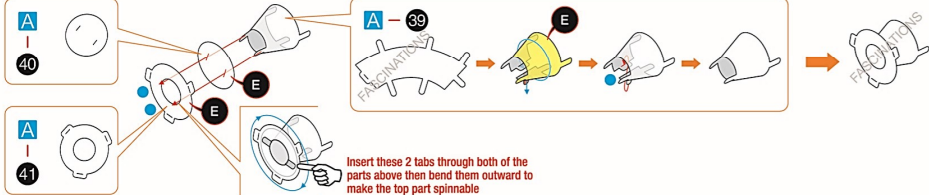

Step 9

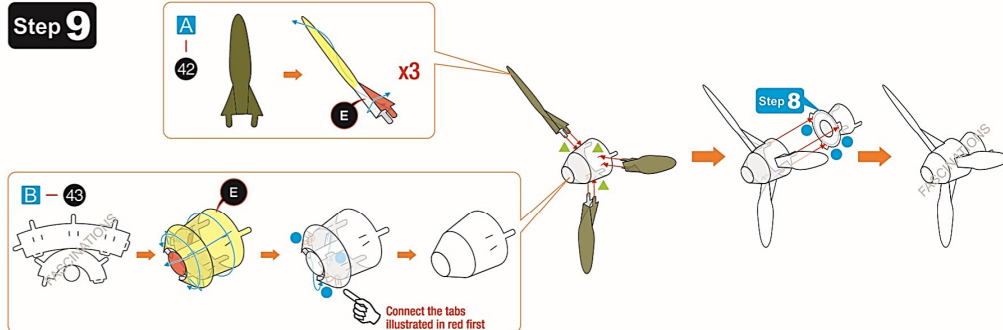

Step 10

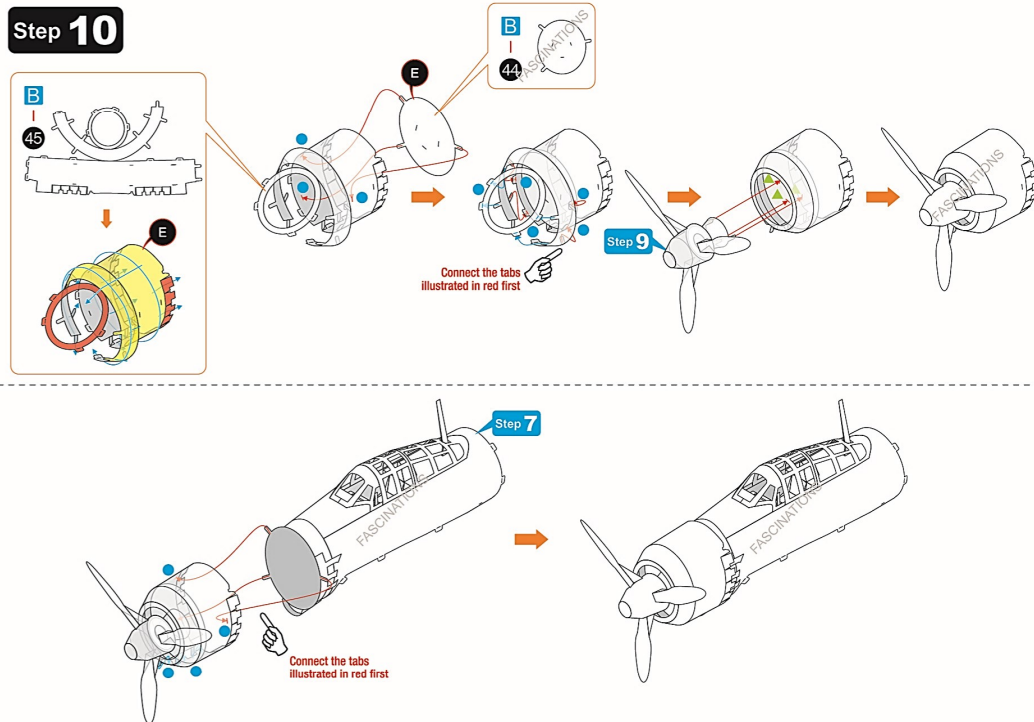

Step 11

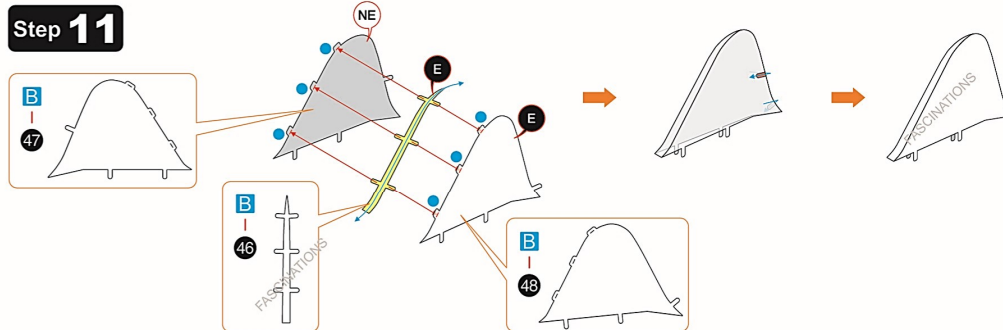

Step 12

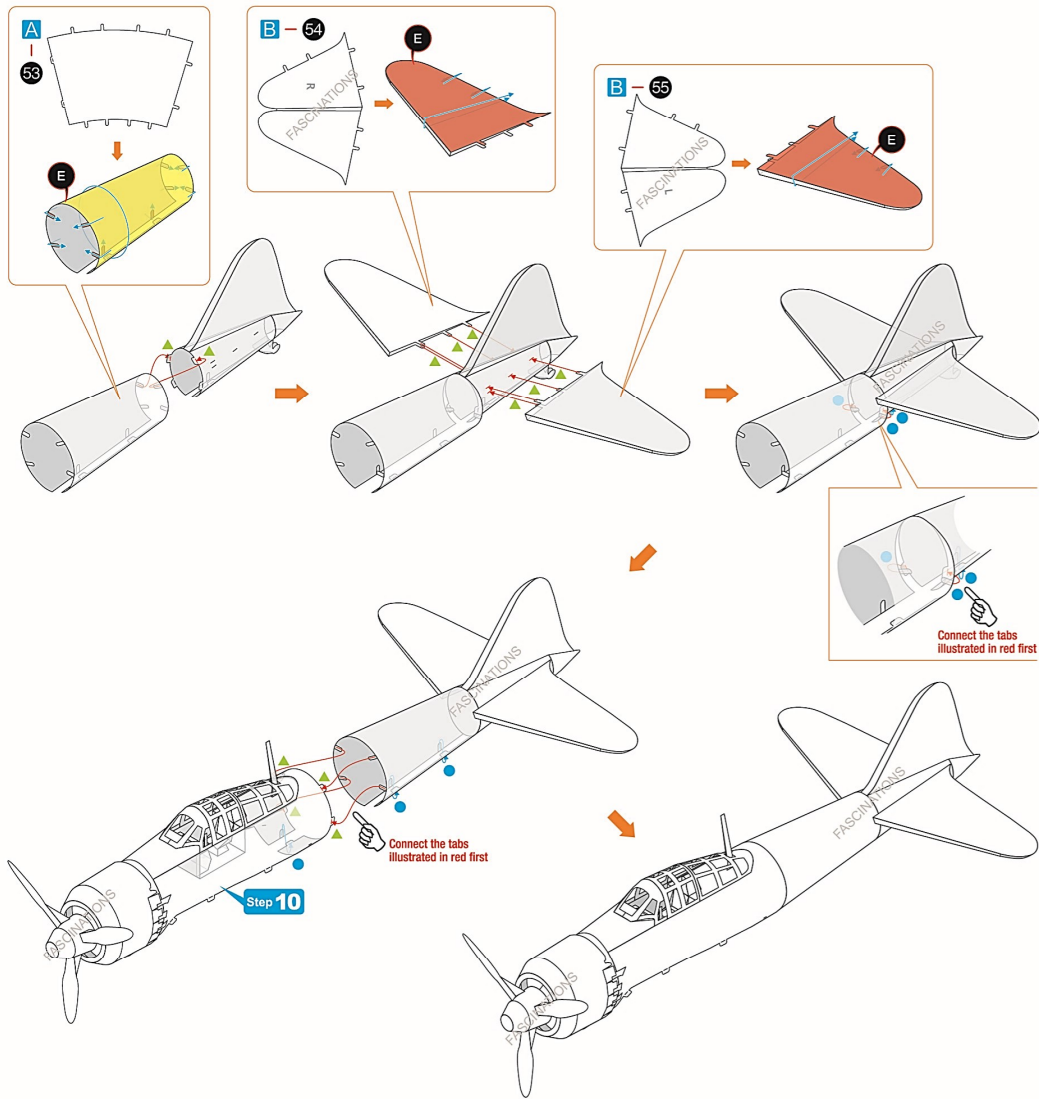
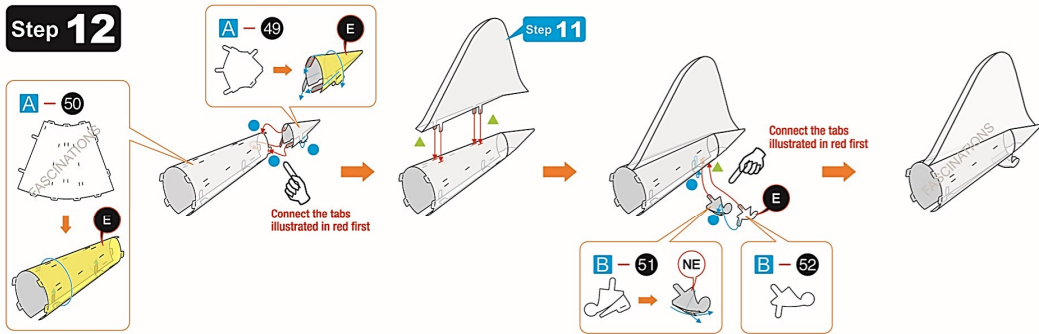

Step 13

