

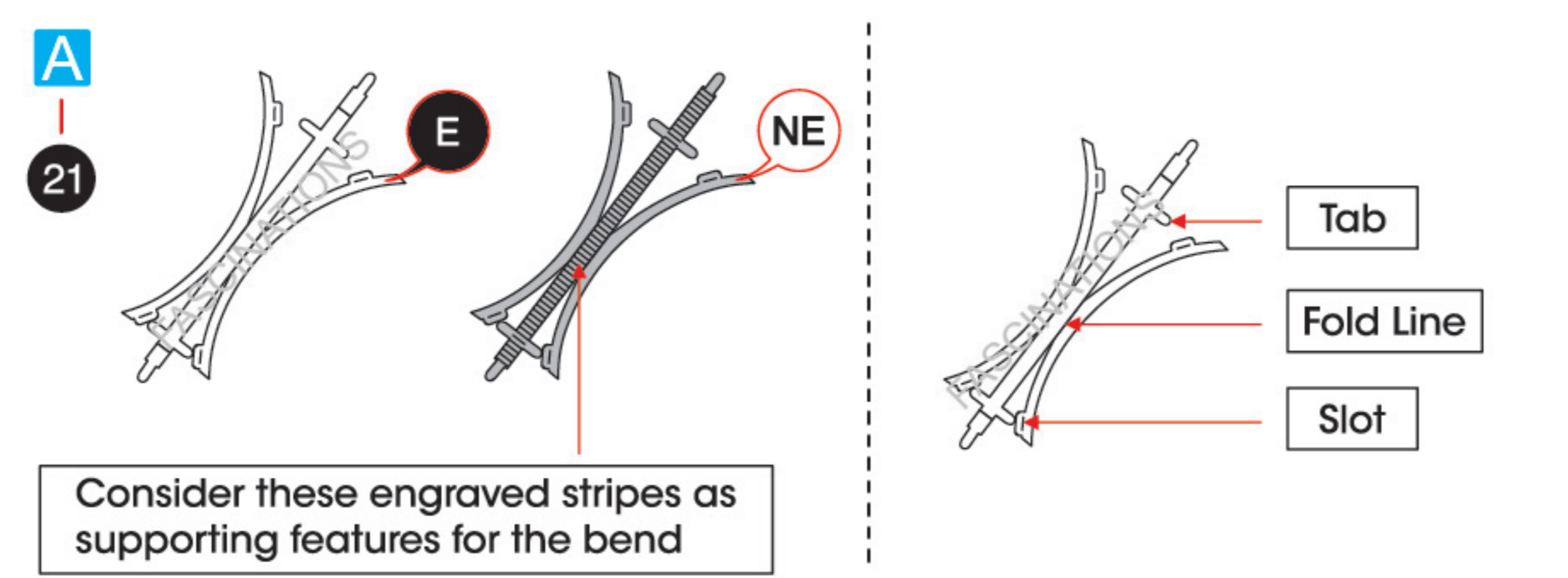

It is highly recommended that you visit [www.metalearth.com/360/ICX244](http://www.metalearth.com/360/ICX244) to see the completed model before assembling your own

## ICX244 THE MANDALORIAN'S N-1 STARFIGHTER™

### TO CREATE THE BEST CONNECTIONS

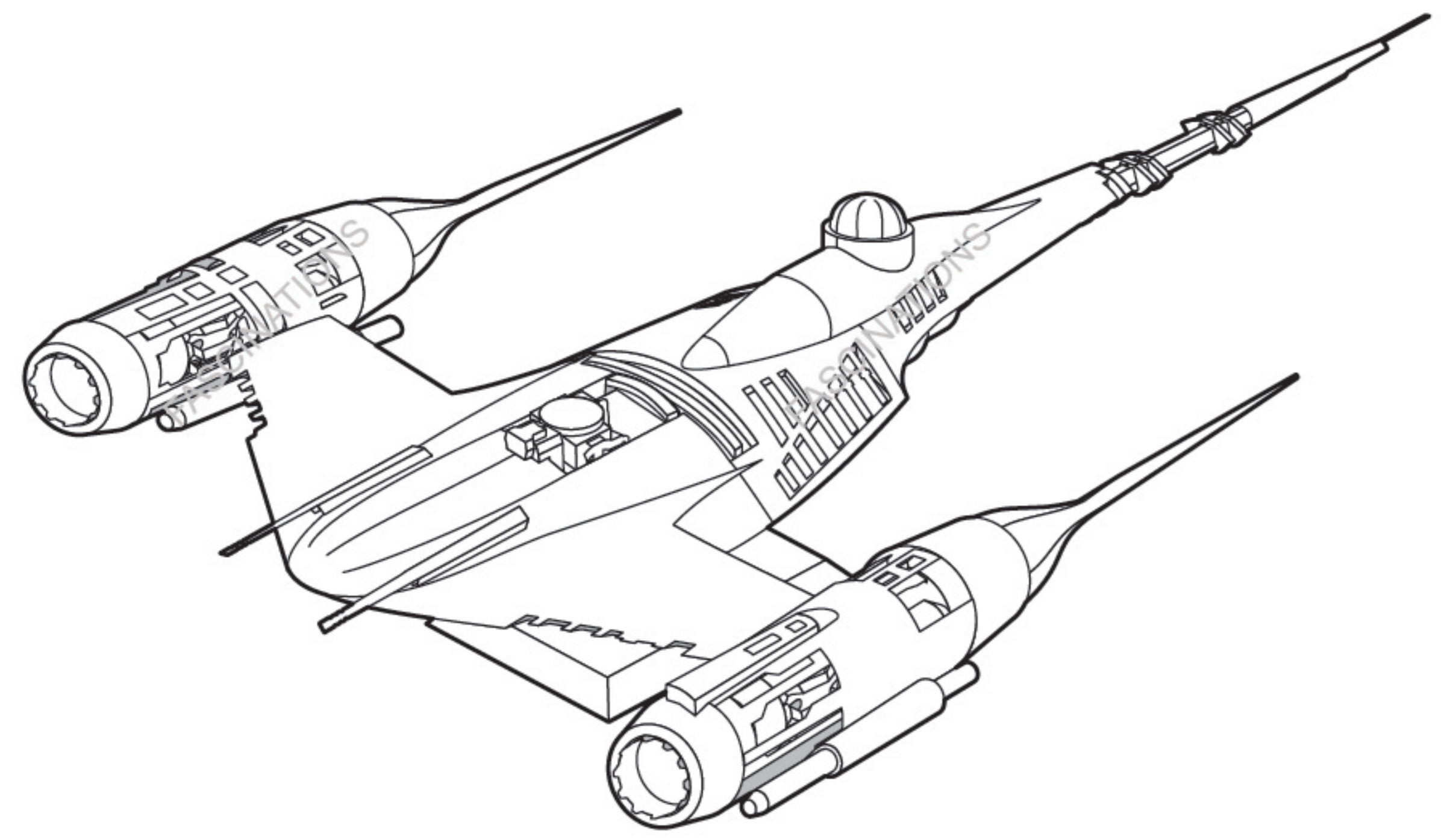

**Legends:**

- E** Engraved/ Color side
- NE** Non - engraved/ Silver side
- Hand icon** Attention point
- Blue dot** Insert tab and bend 90 degrees
- Green triangle** Insert tab and twist 90 degrees

**Assembly tip:**  
If needed, slightly twist tabs to hold parts together then untwist and bend them down for a nice finish.

- Yellow areas** should be curled
- Red areas** should be folded

**Recommended tools:**

- Wire cutters: helpful for taking parts from the metal sheets.
- Tweezers or needle nose pliers: helpful for folding parts, bending and twisting tabs.

### METAL SHEETS

Parts with same color are duplicates

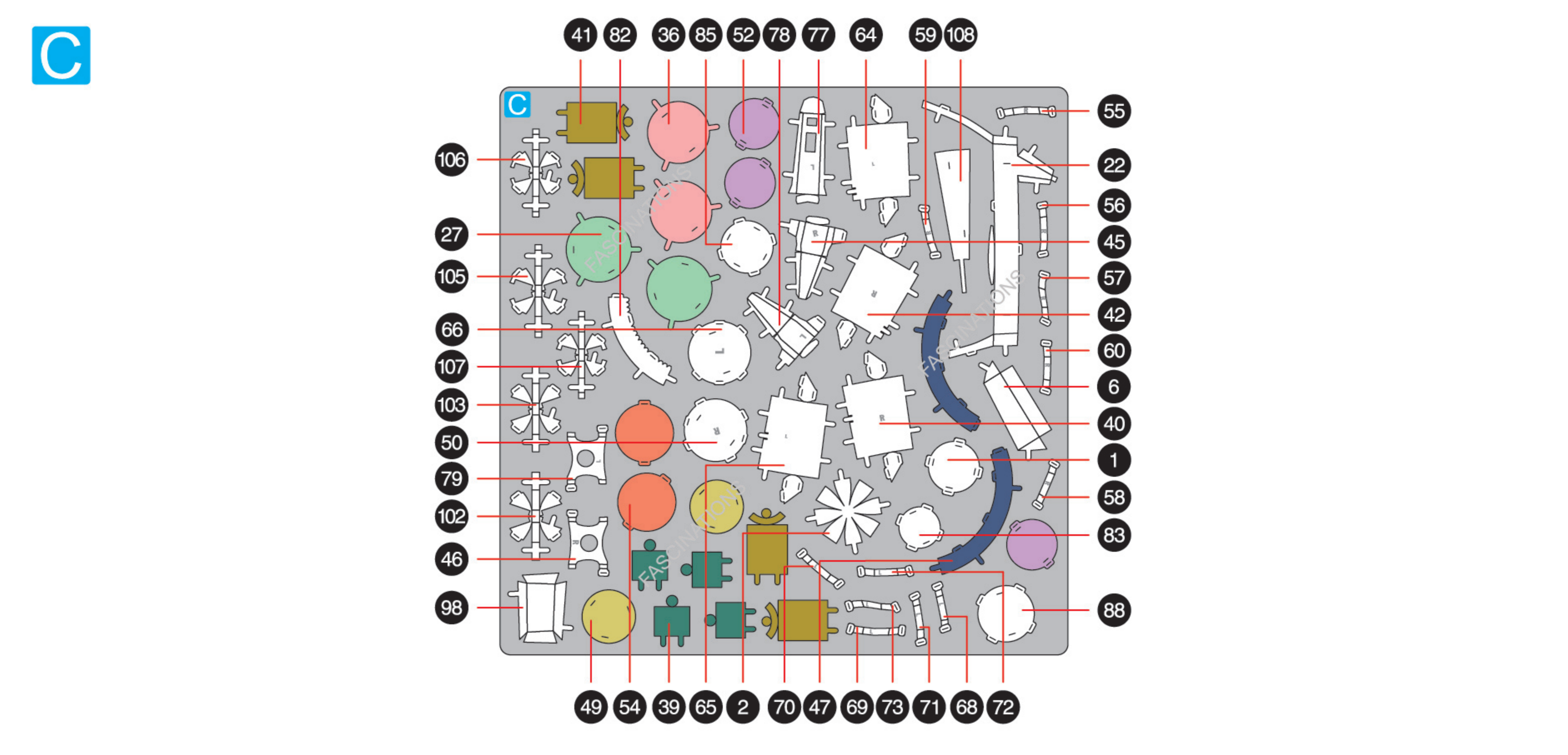
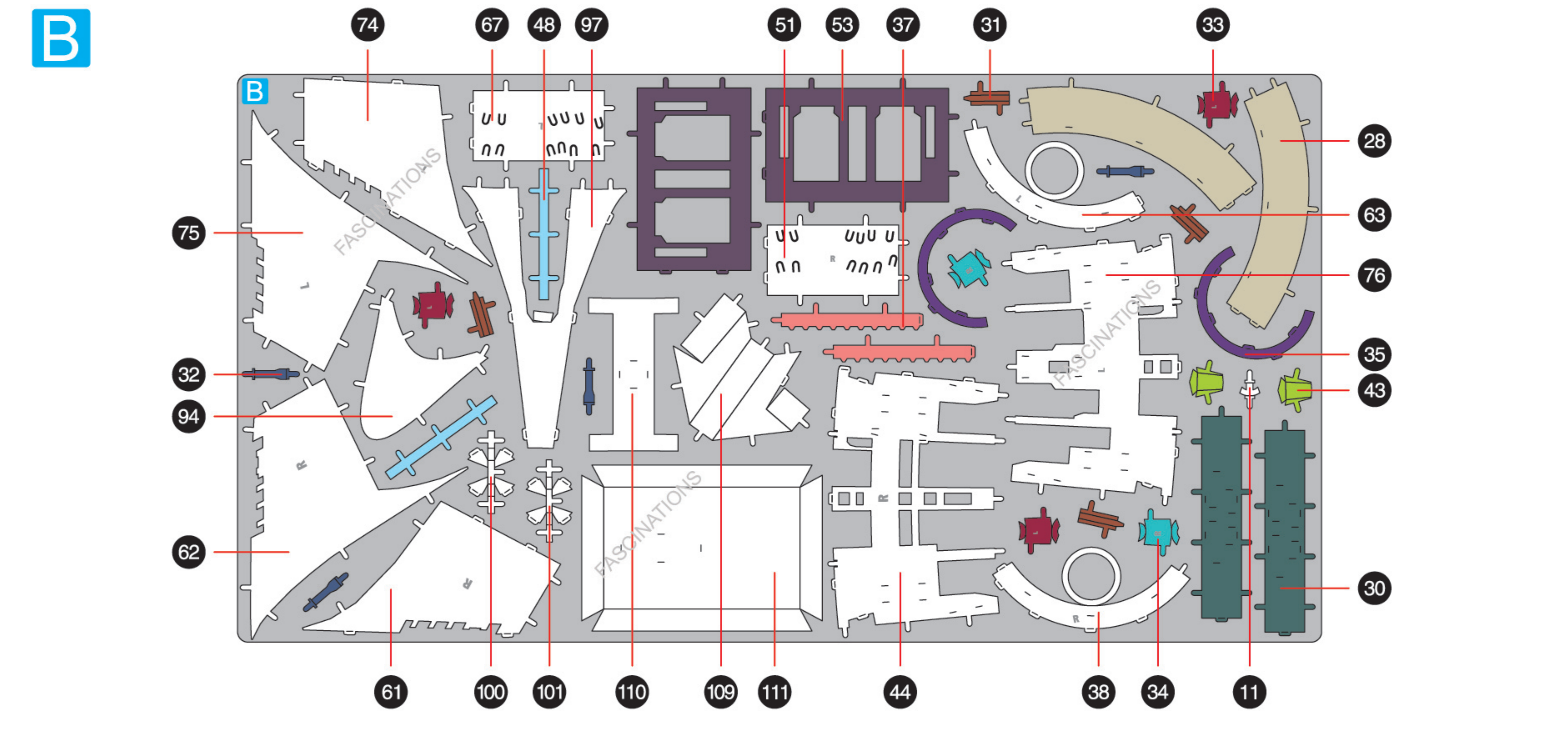
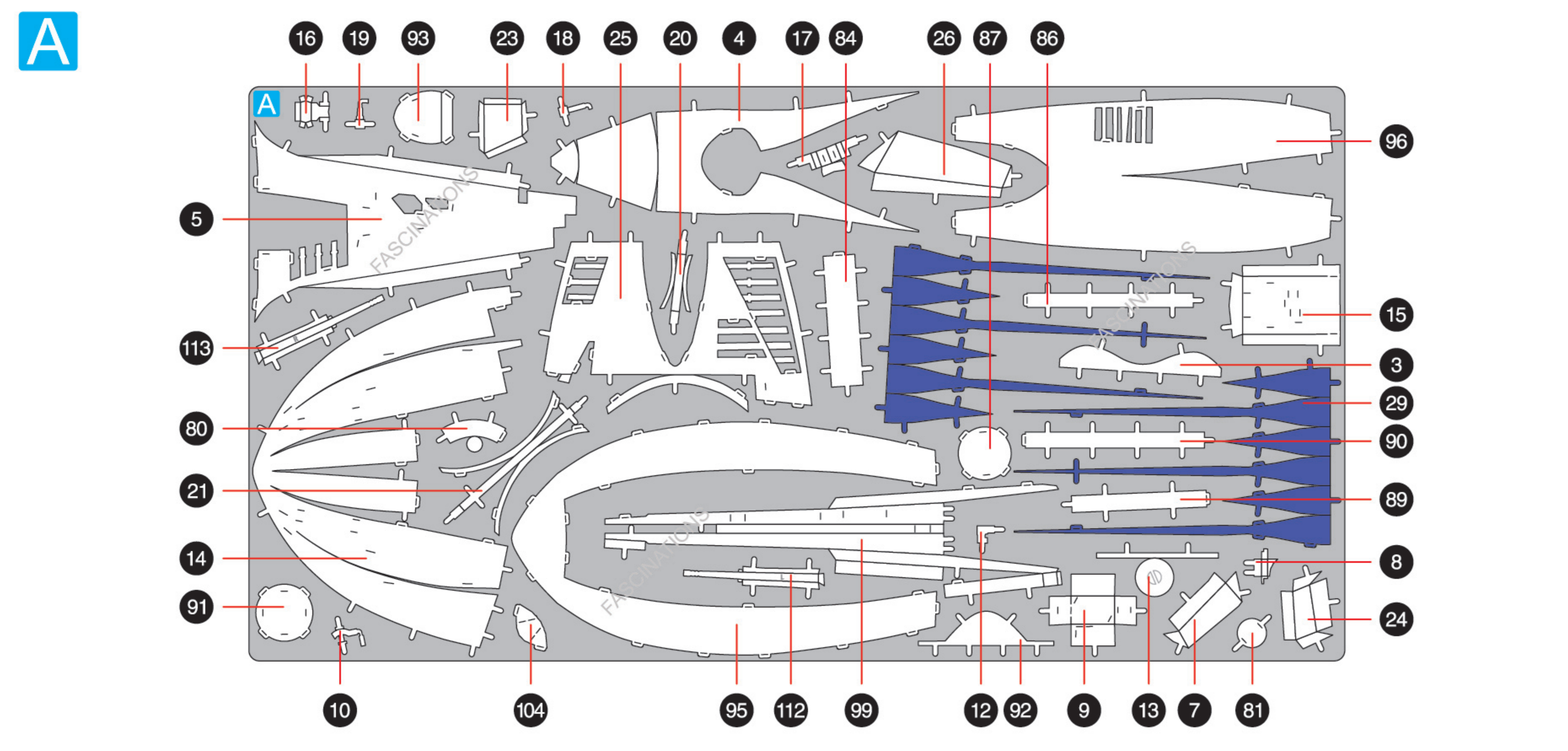

### ASSEMBLY STEPS

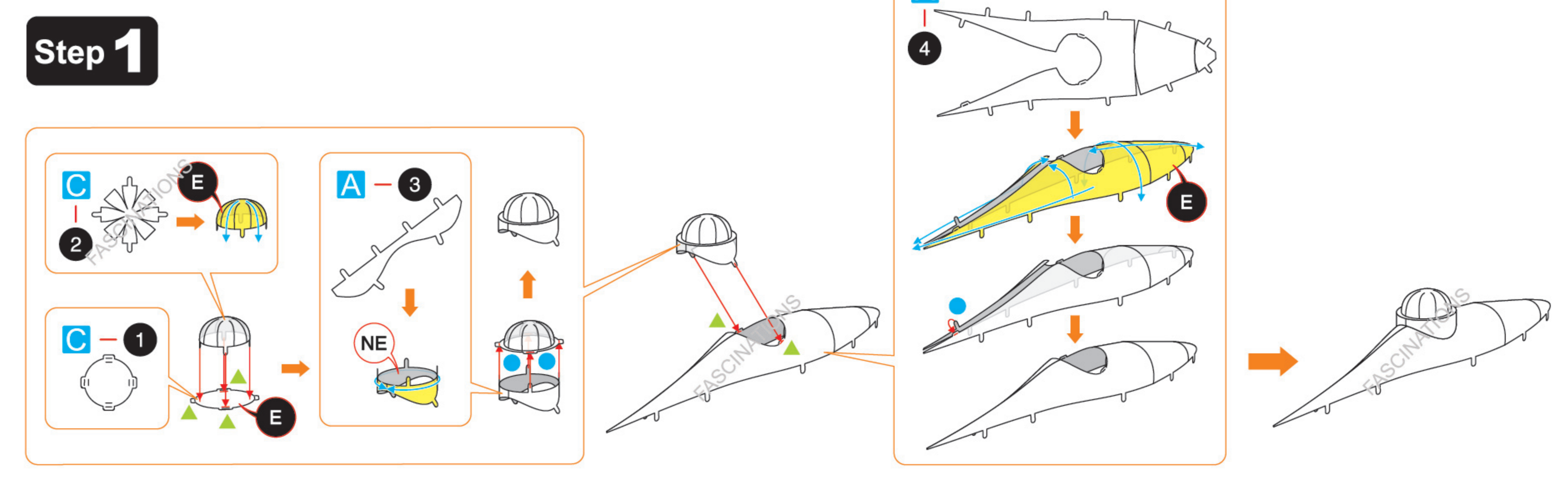

Step 2

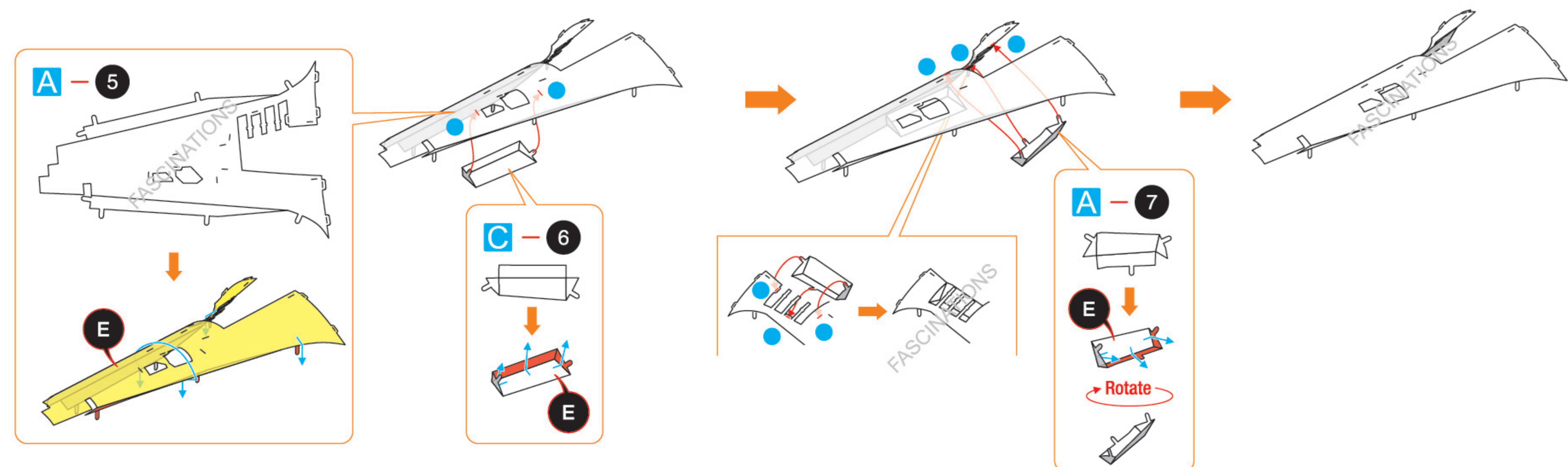

Step 3

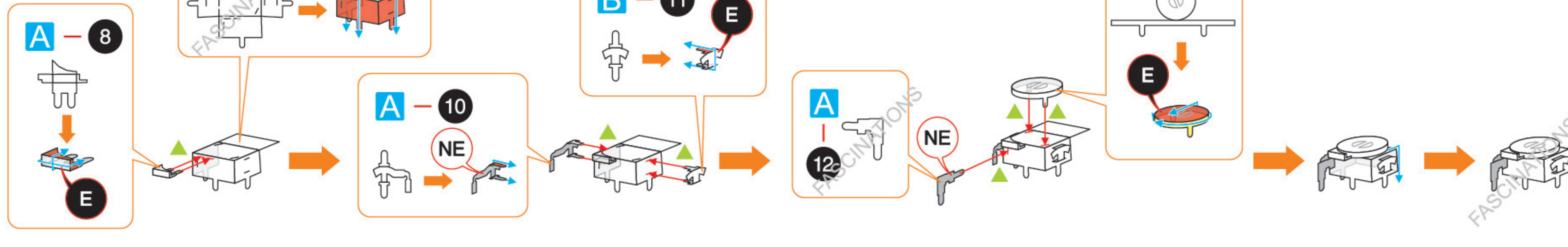

Step 4

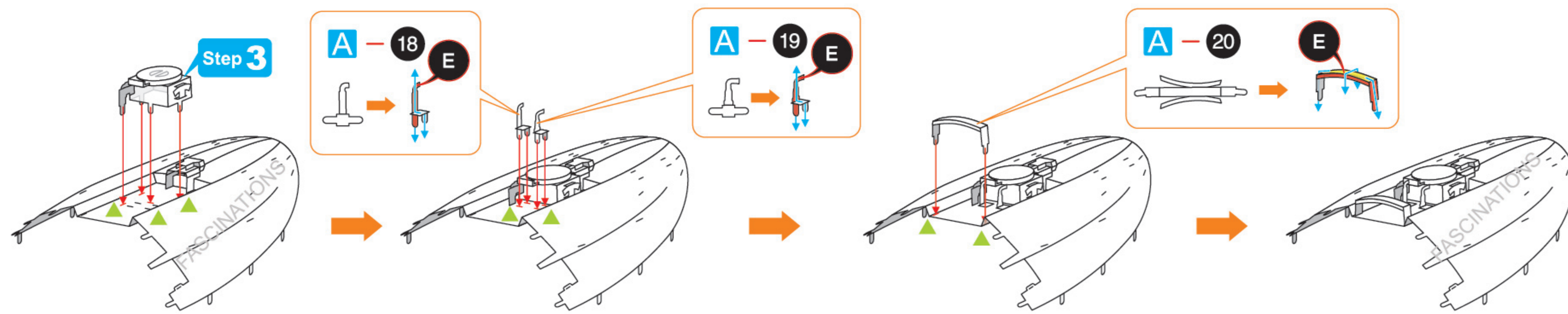
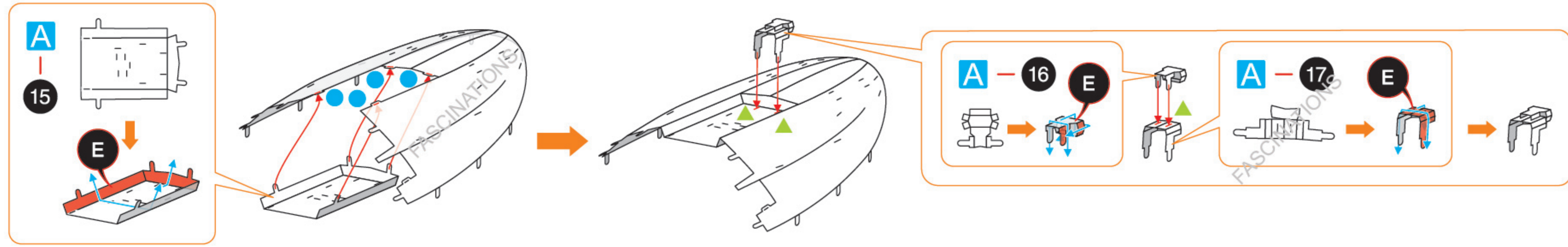
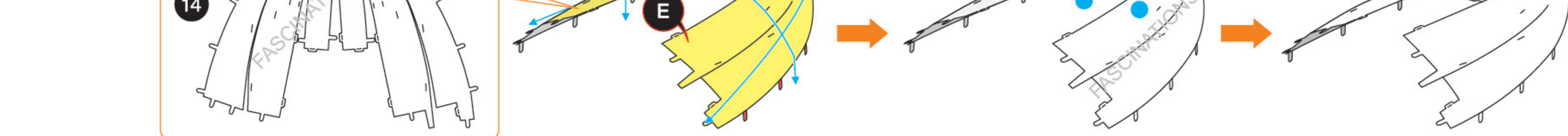

Step 5

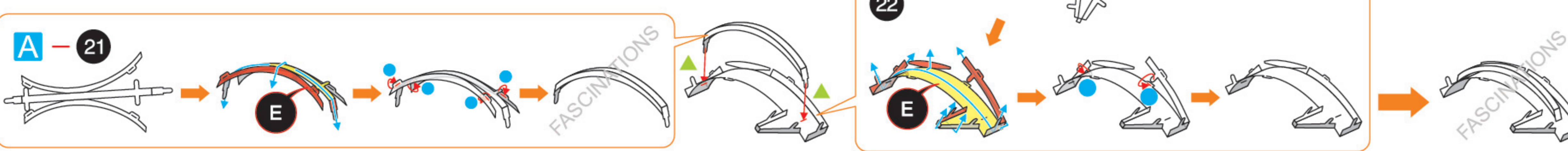

Step 6

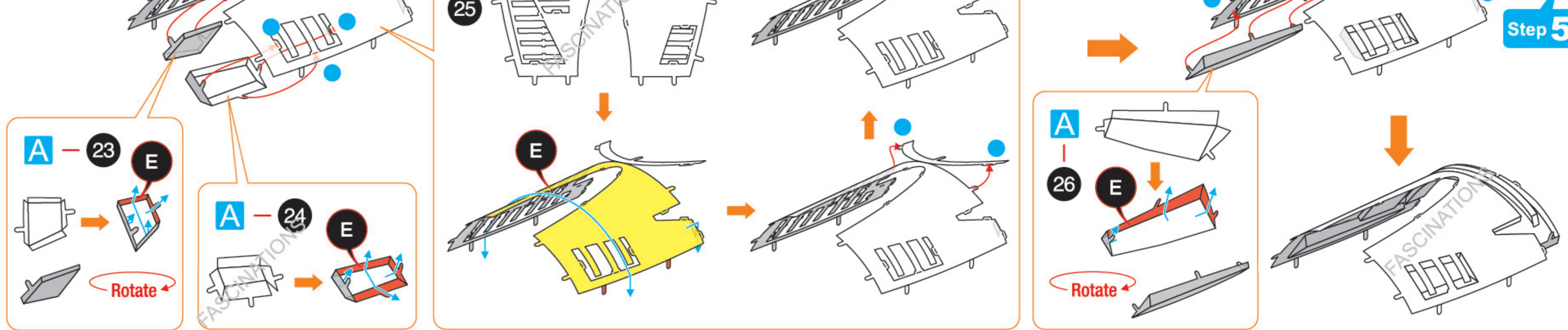

Step 7

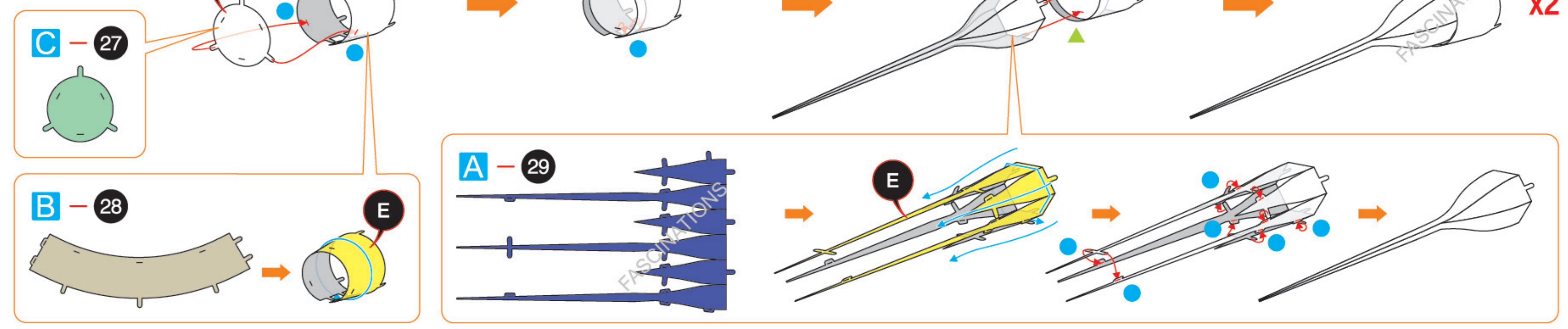

Step 8

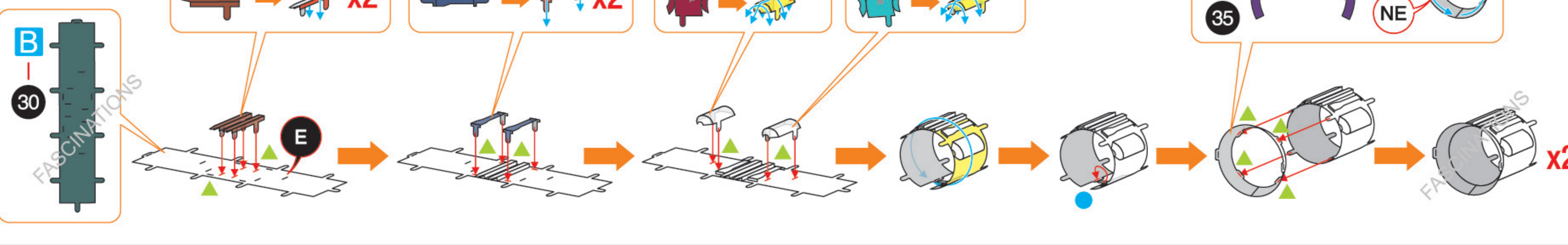

Step 9

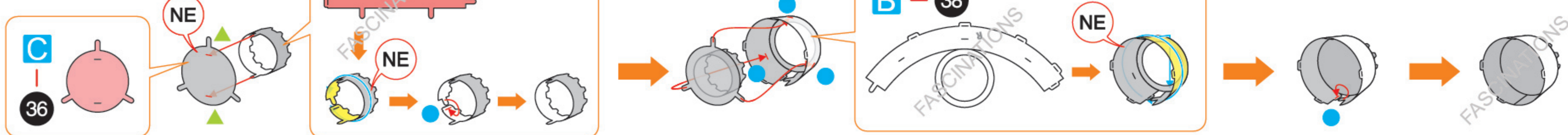

Step 10



Step 11

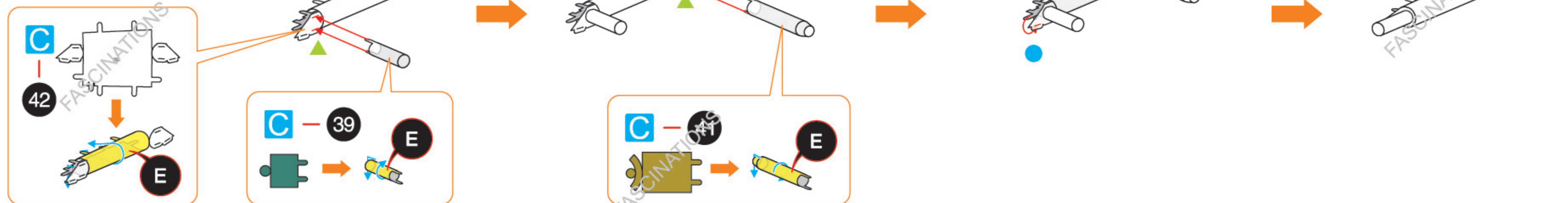

Step 12

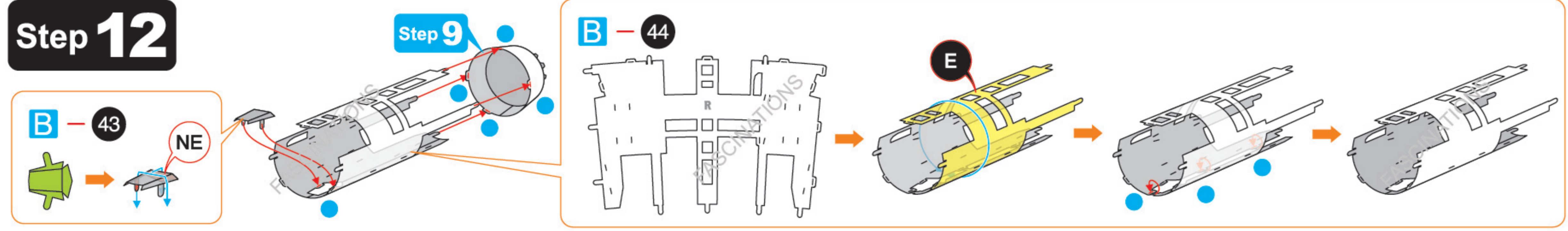

Step 10

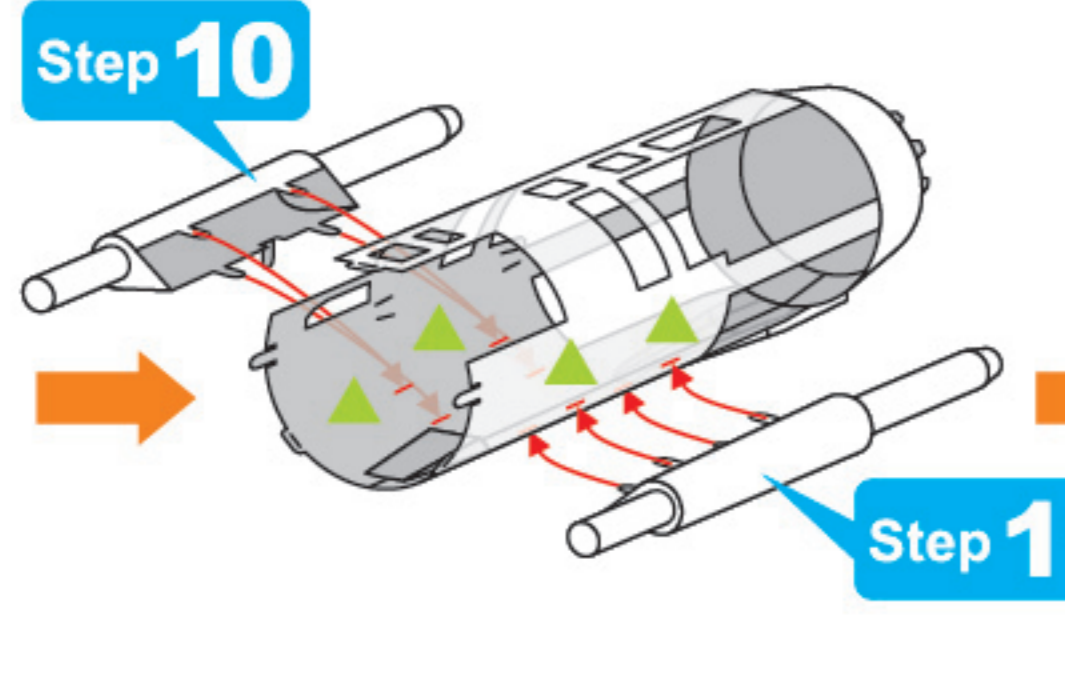

Step 11

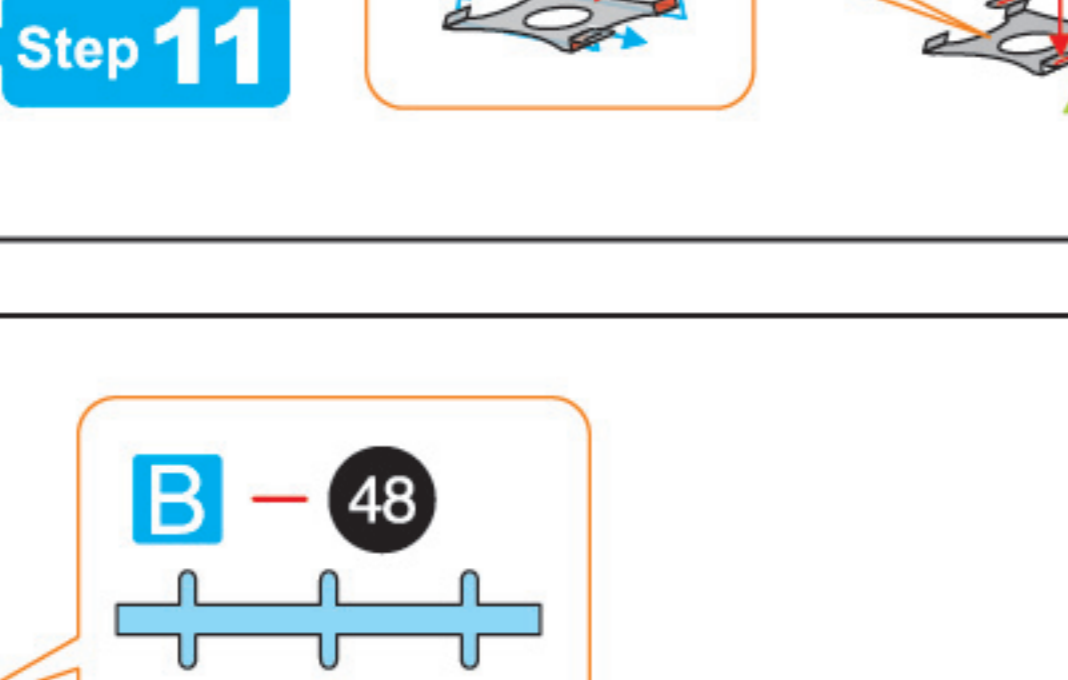

Step 13

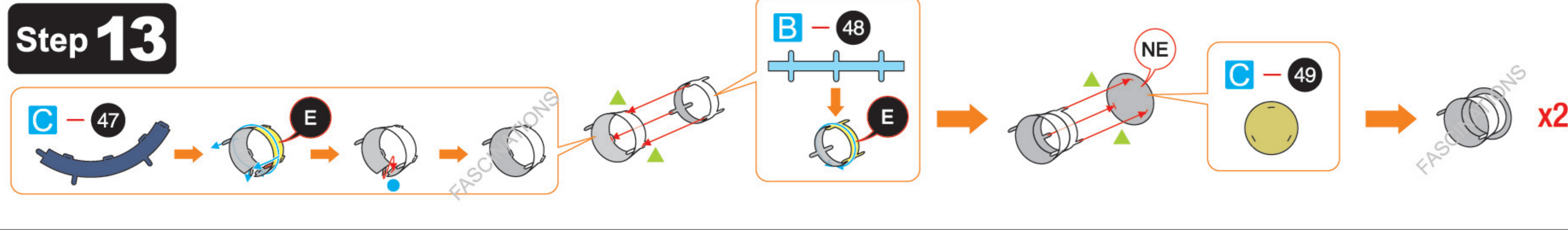

Step 14

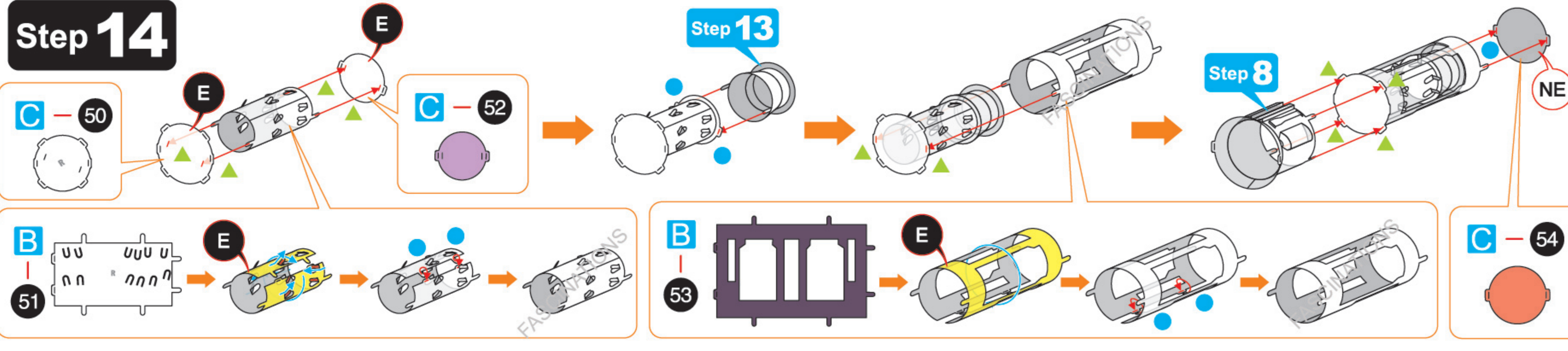

Step 15

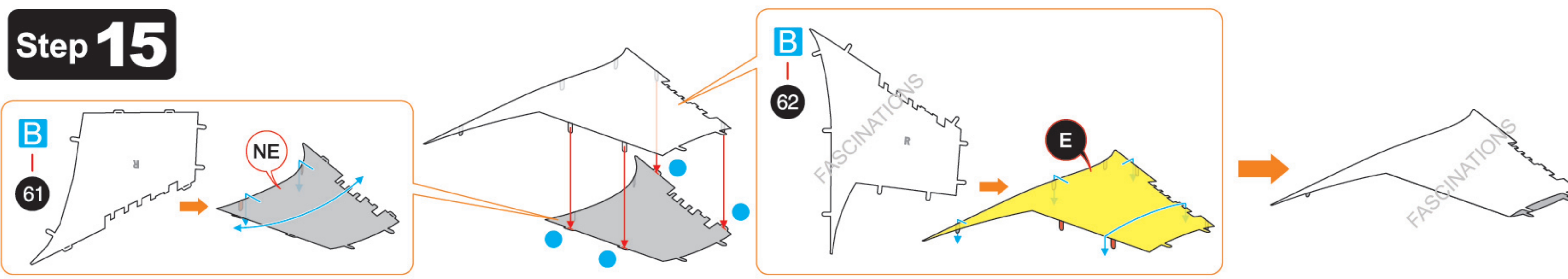

Step 16

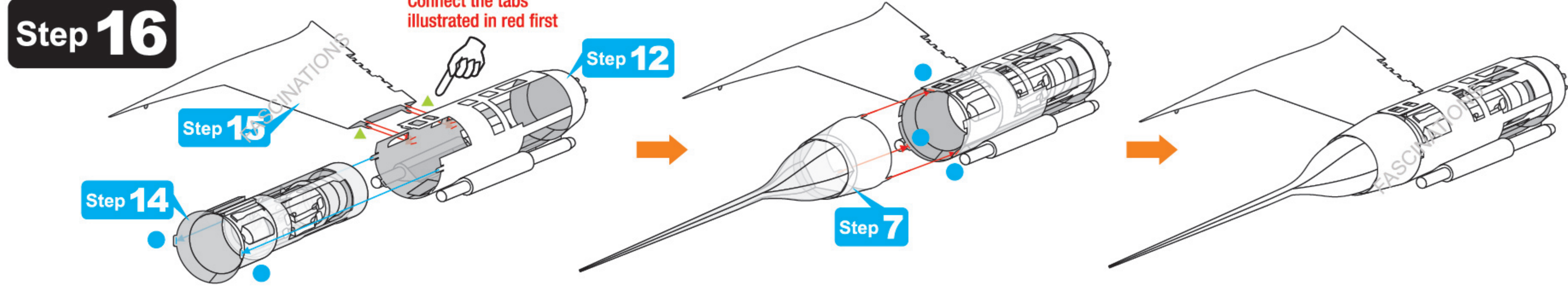

Step 17

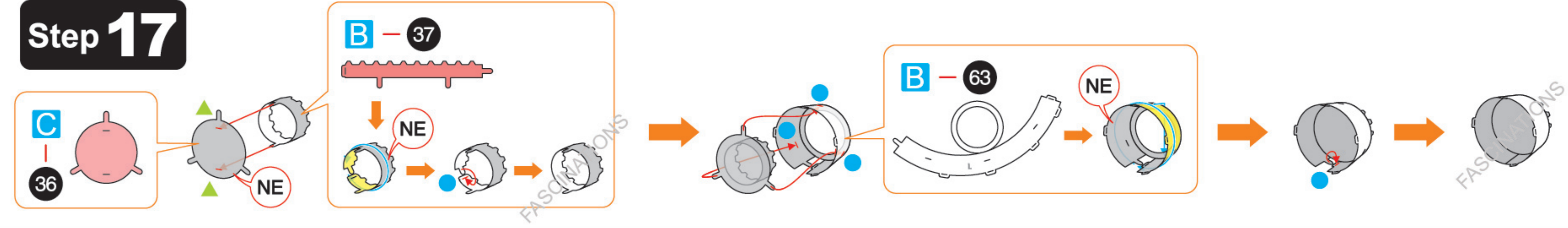

Step 18

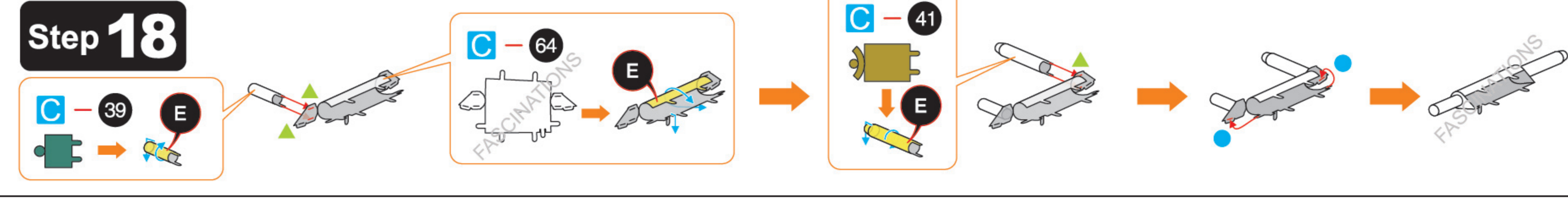

Step 19

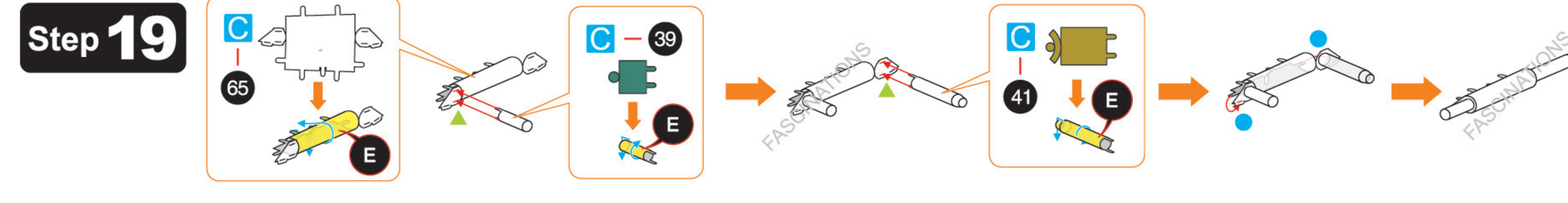

Step 20

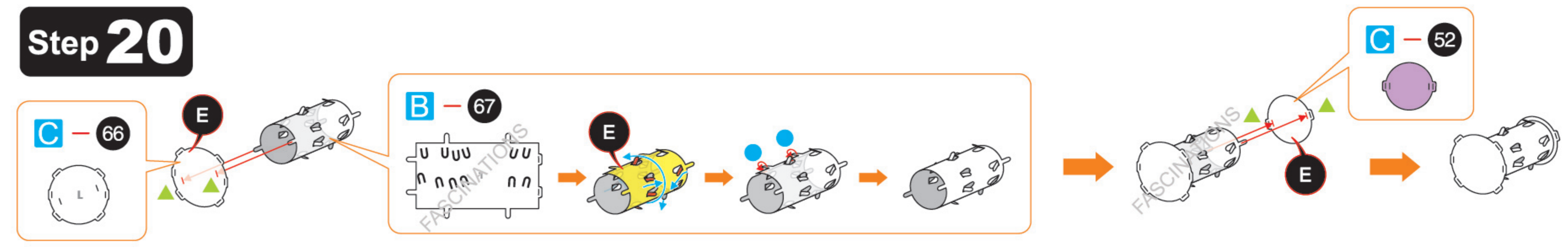

Step 21

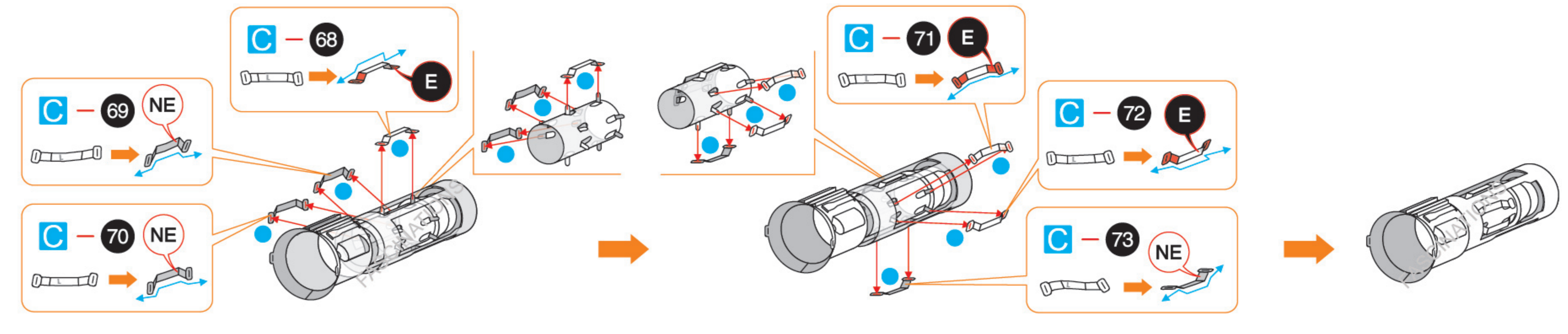
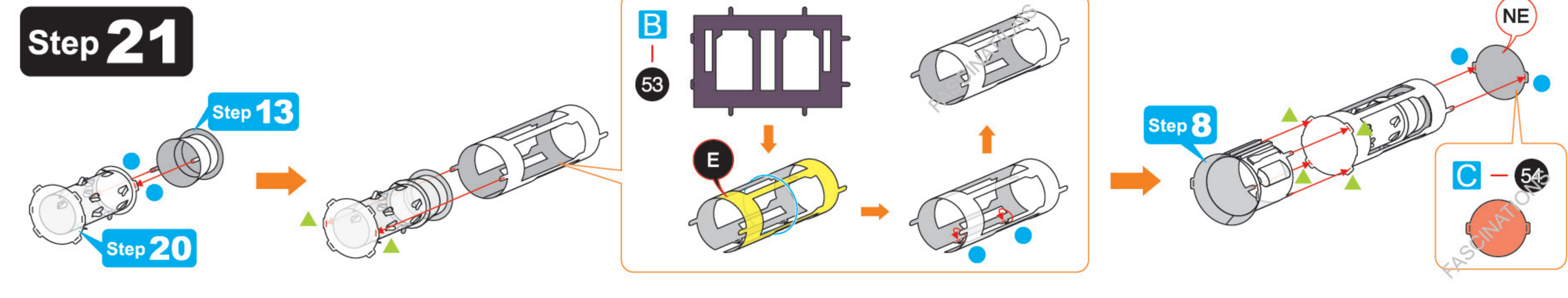

Step 22

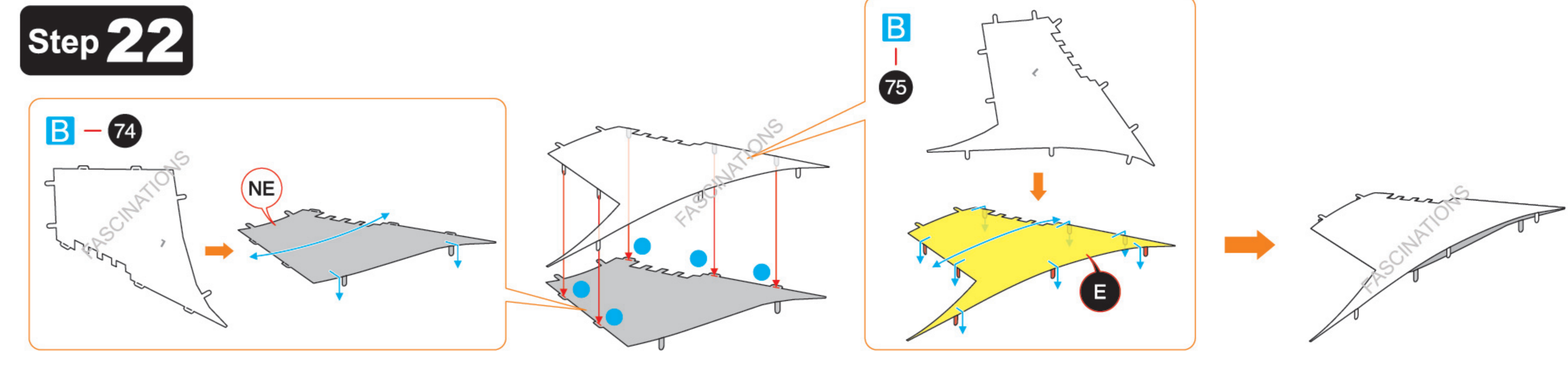

### Step 23

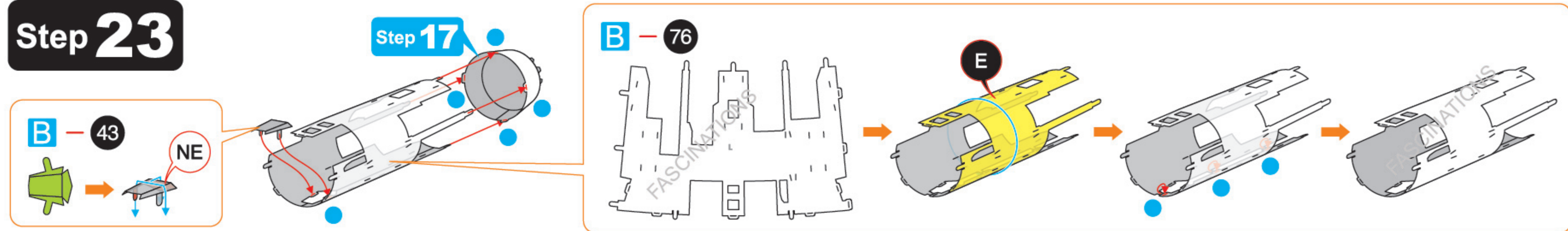

### Step 17

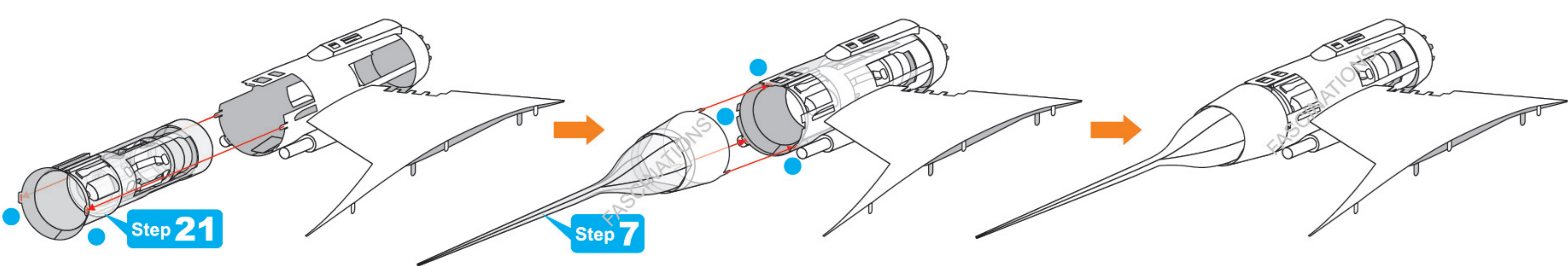
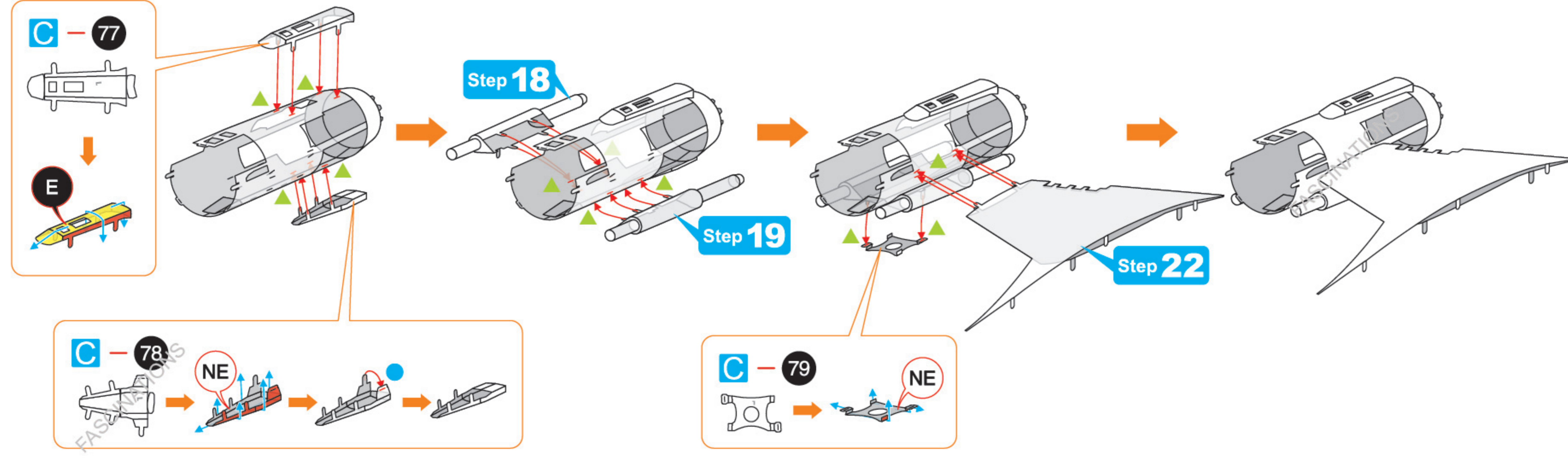

### Step 24

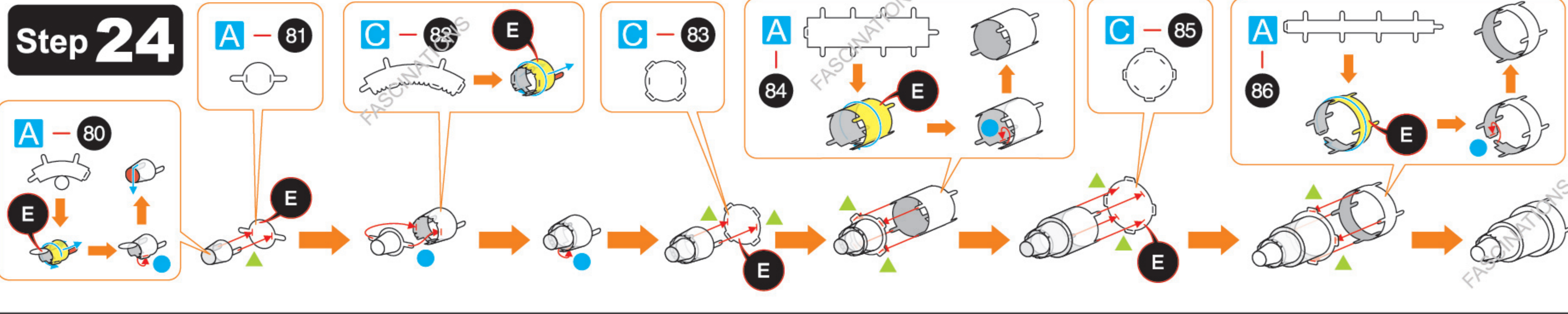

### Step 25

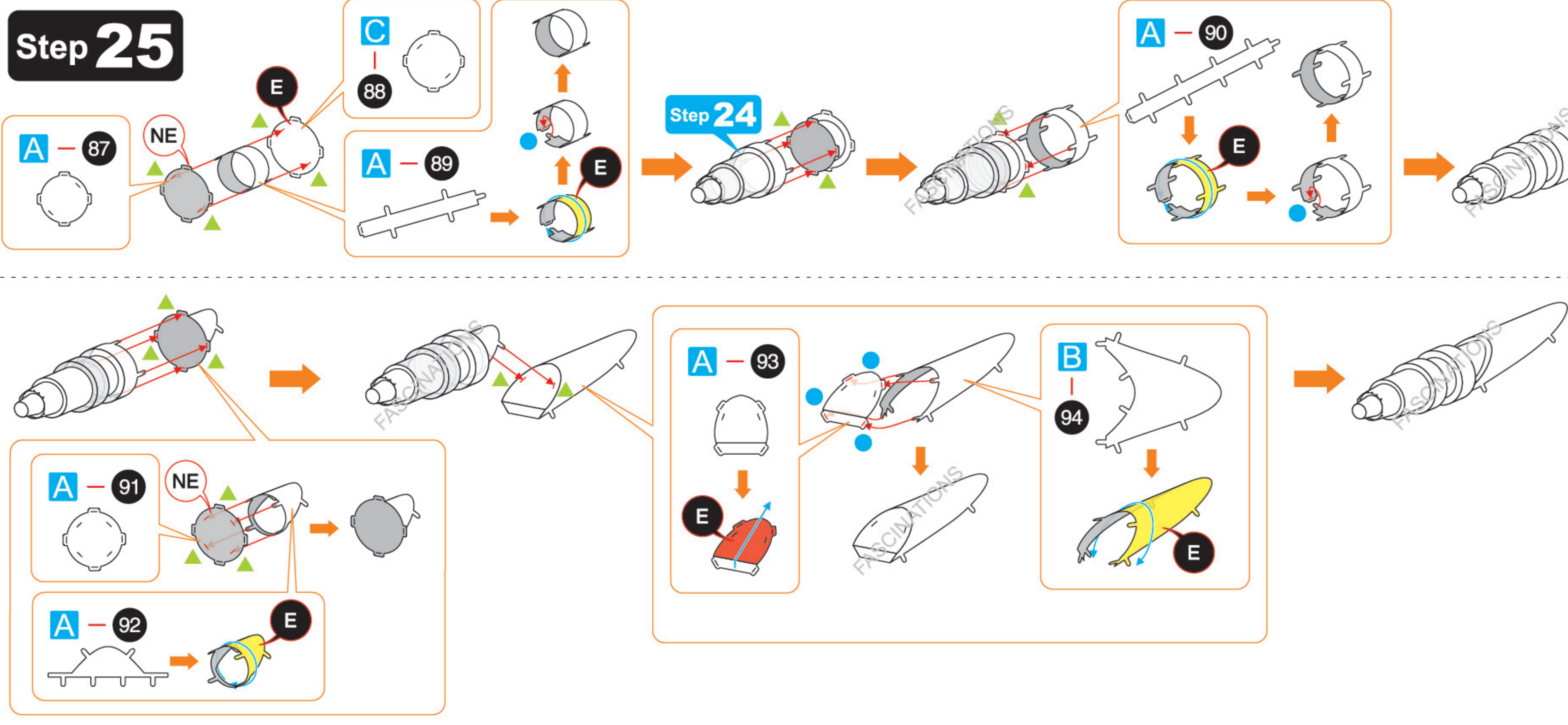

### Step 26

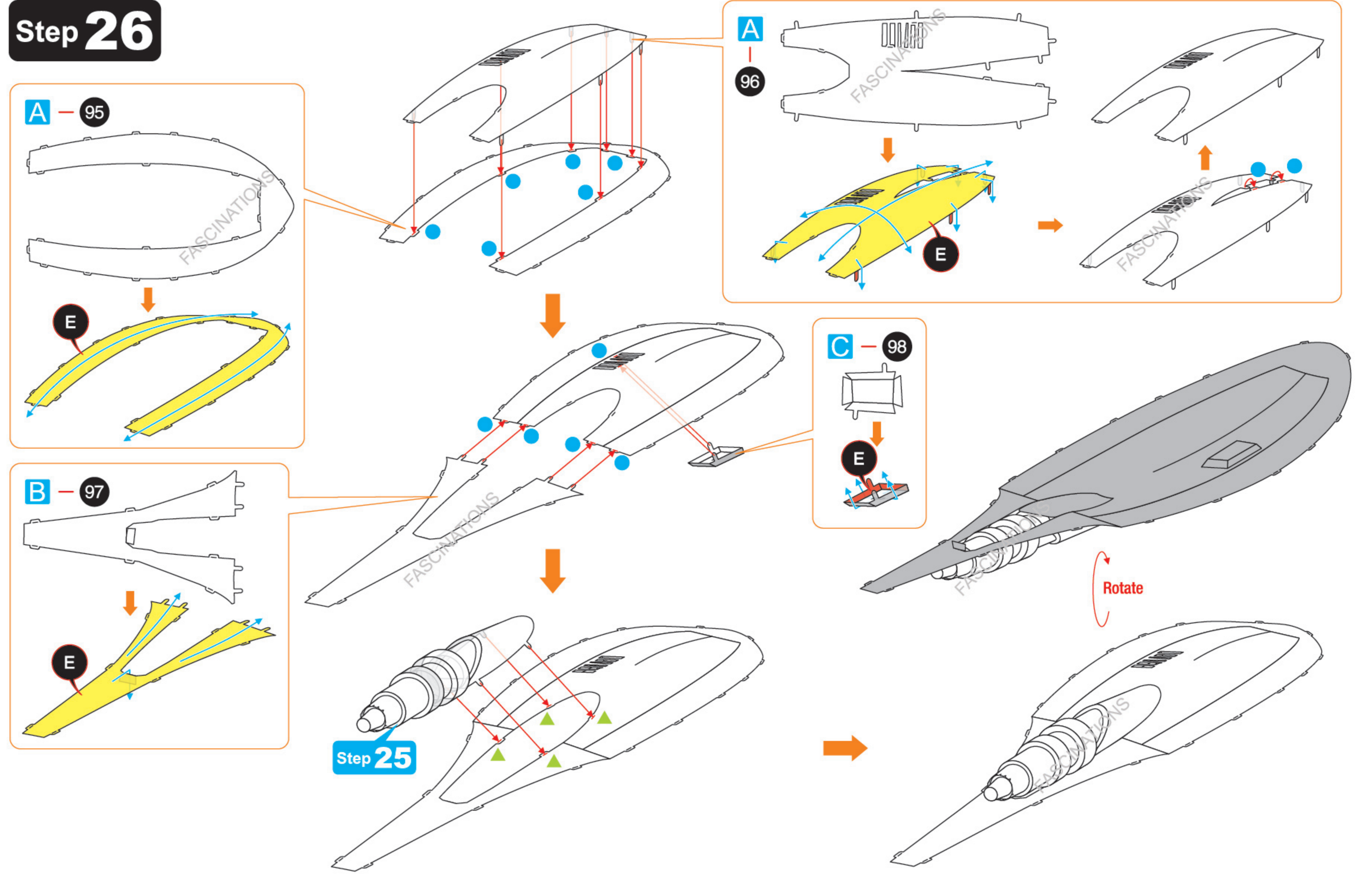

### Step 27

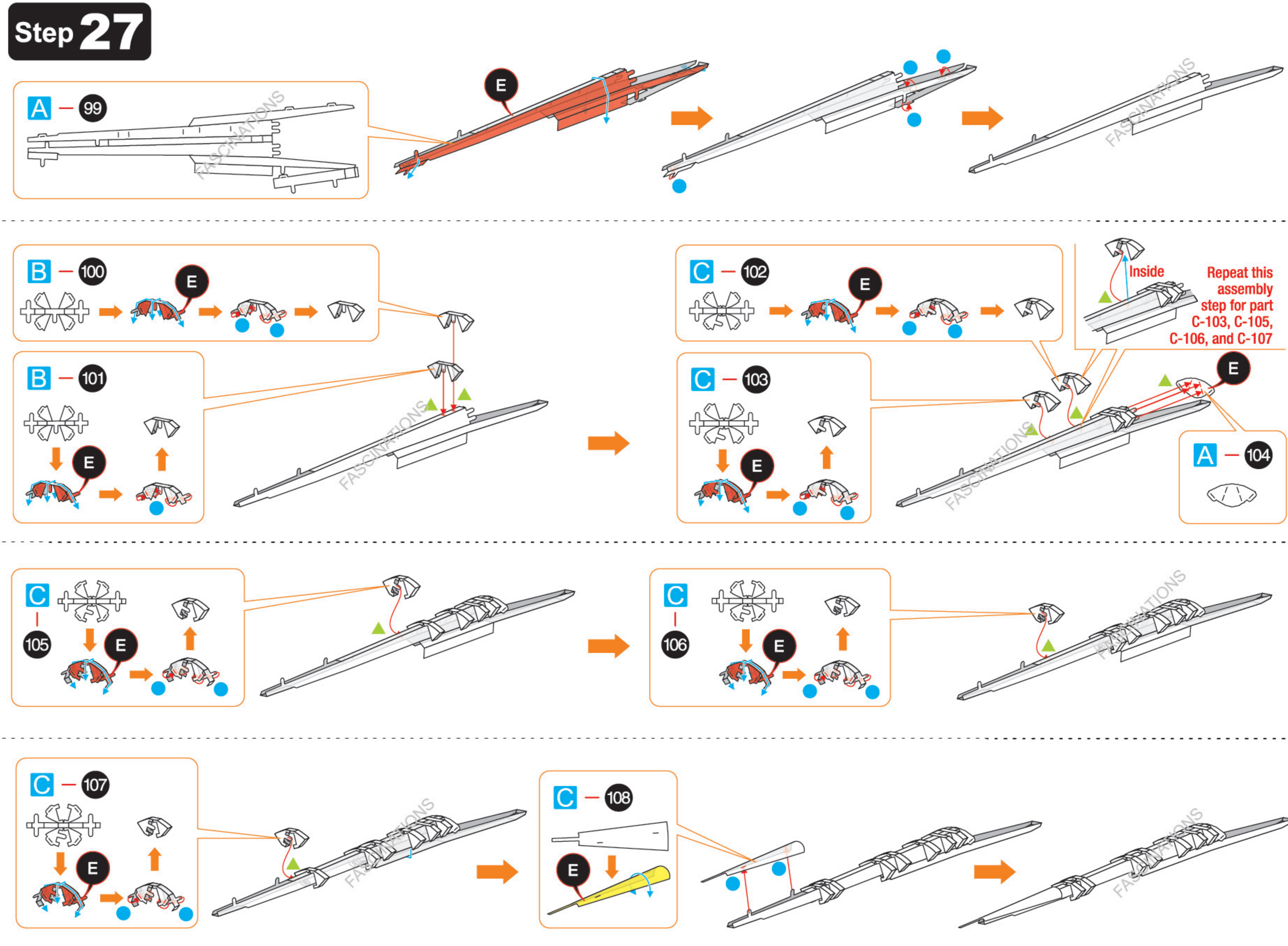

Step 28

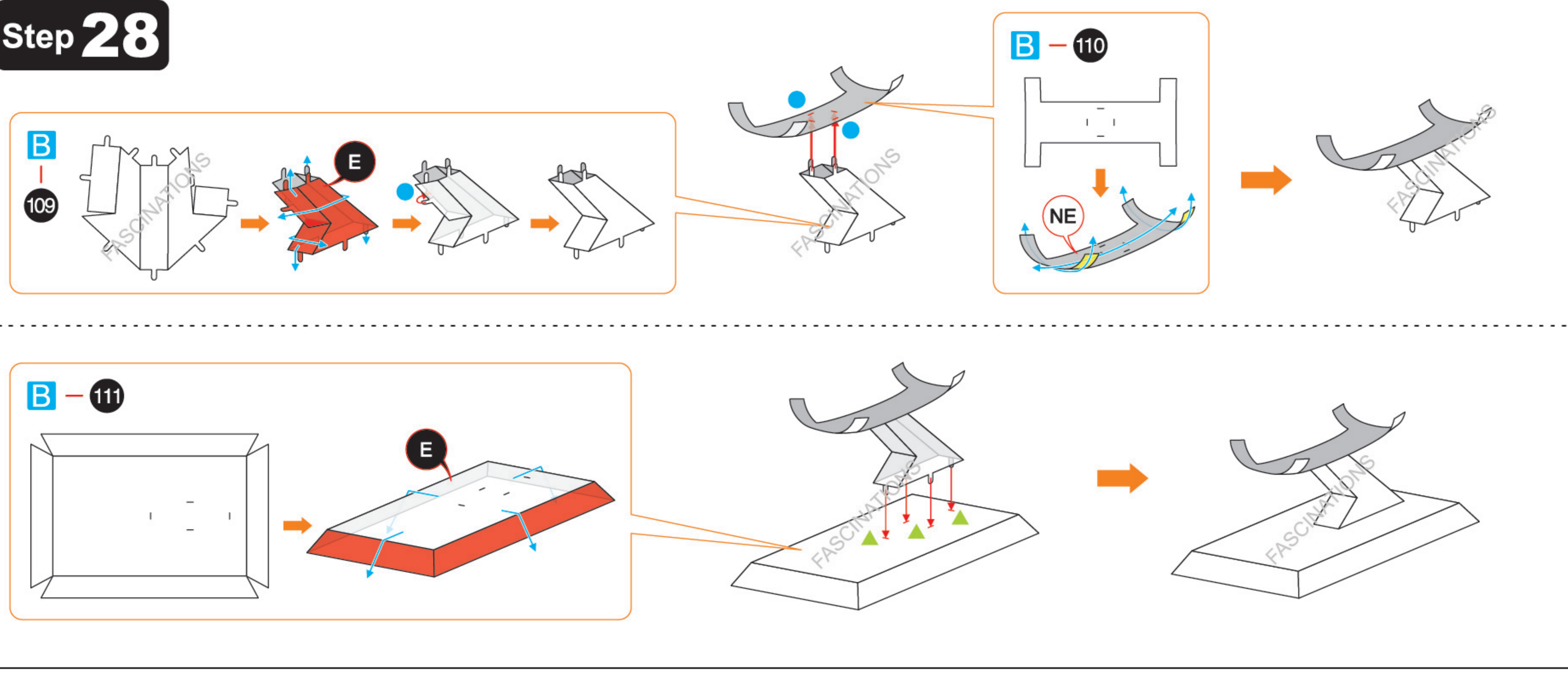

Step 29

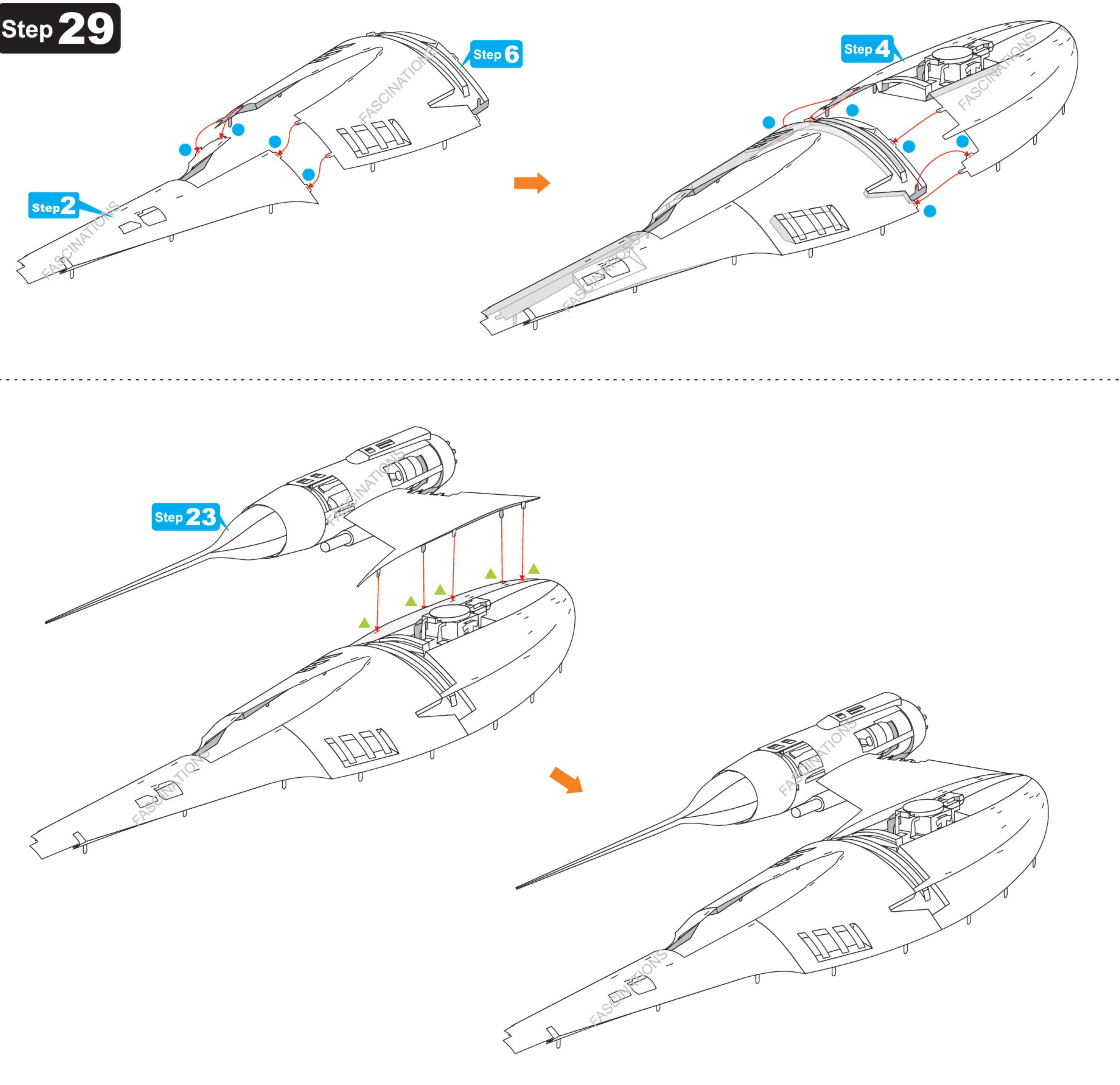

Step 30

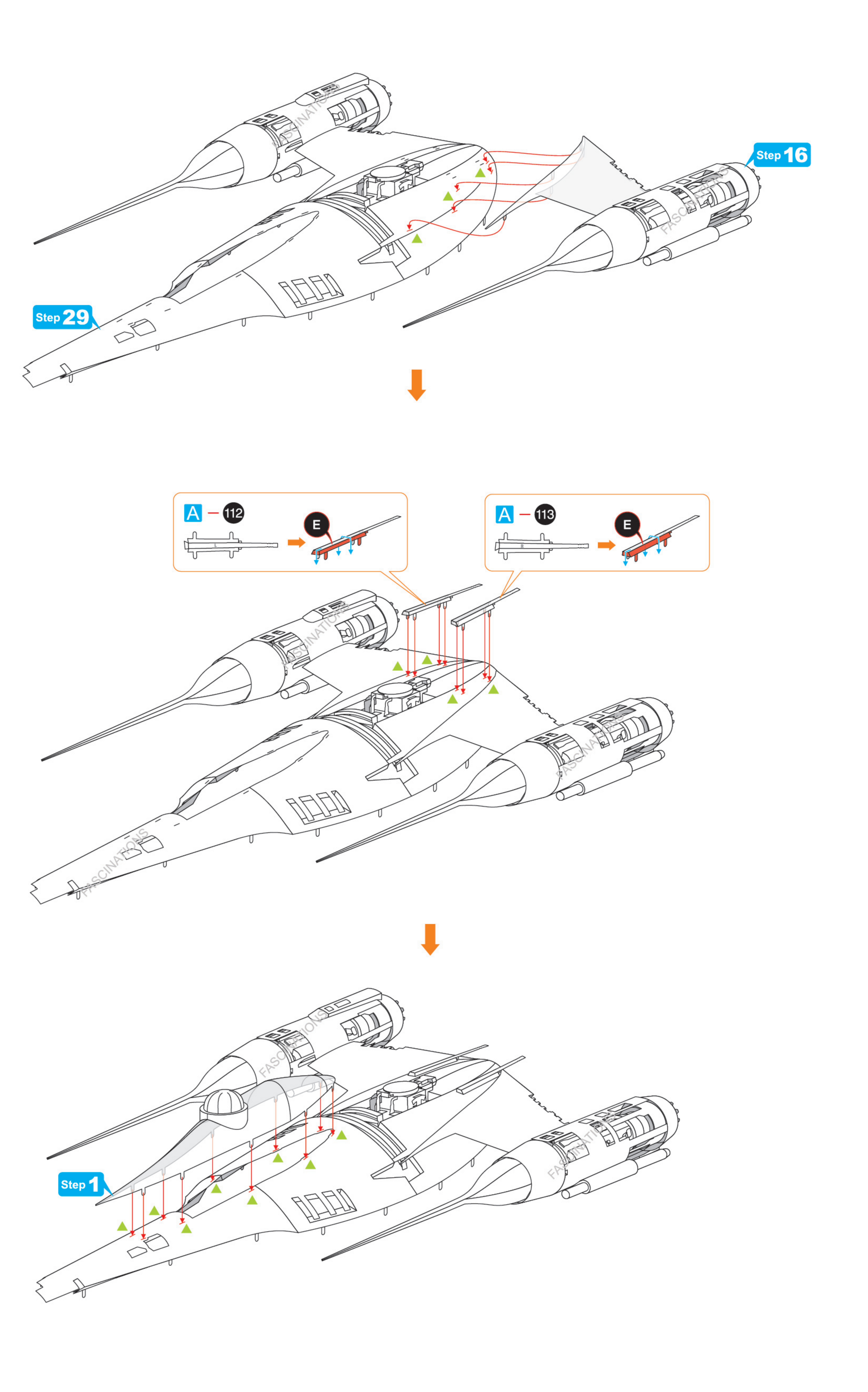

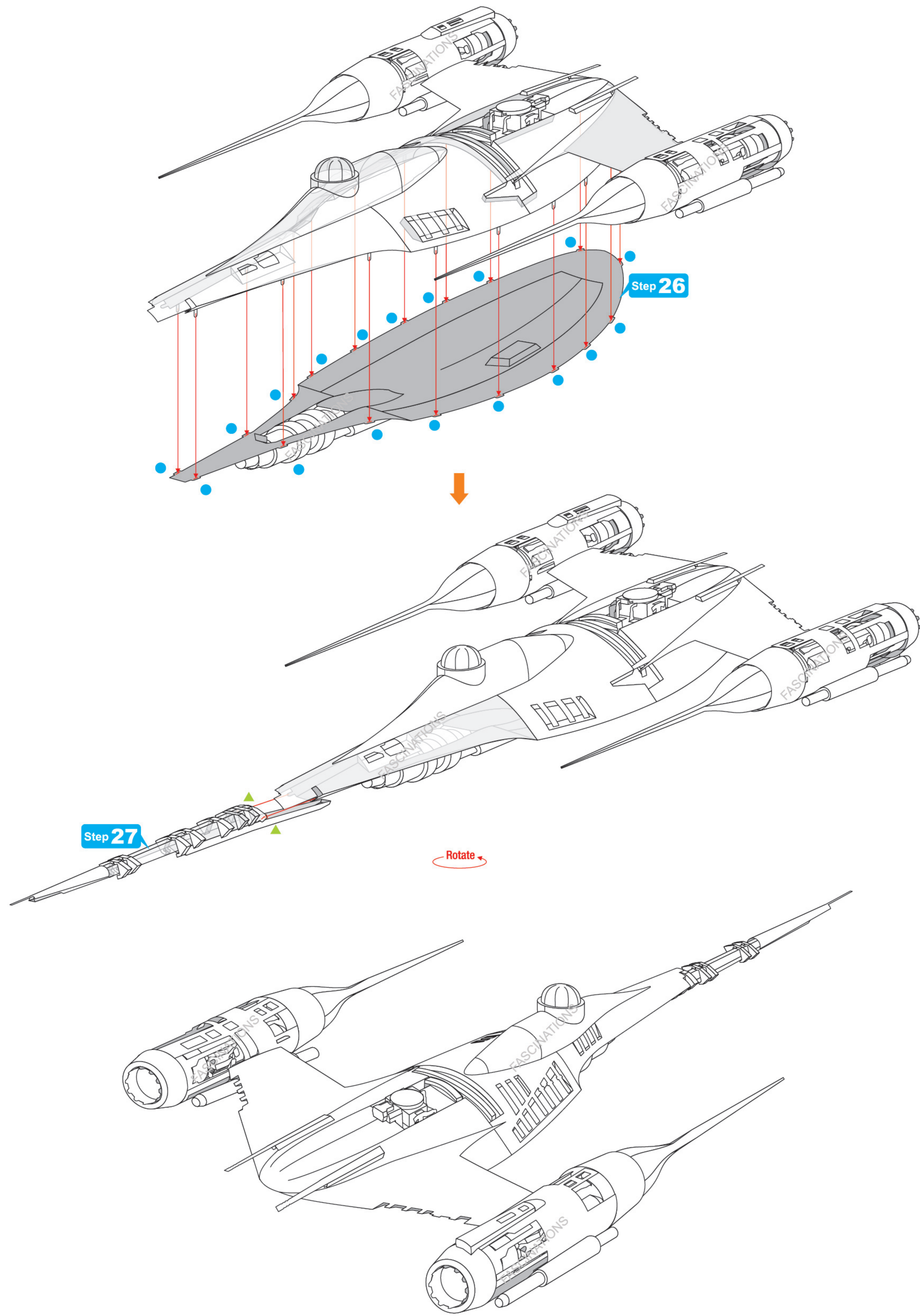

Step 31

