

NIMBUS 2000™ ME1031

It is highly recommended that you visit www.metalearth.com/360/ME1031 to see the completed model before assembling your own

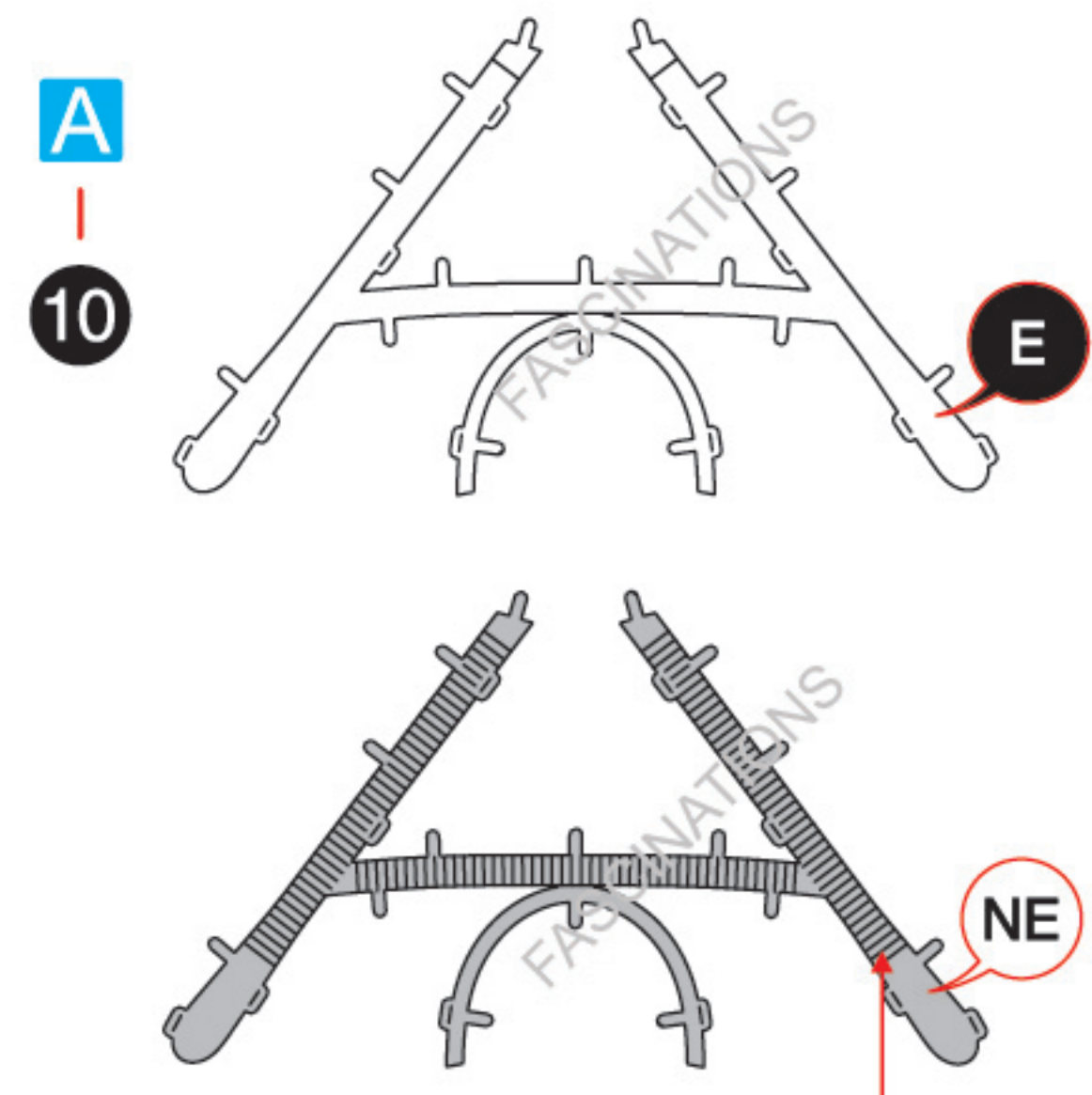

TO CREATE THE BEST CONNECTIONS



Consider these engraved stripes as supporting features for the bend

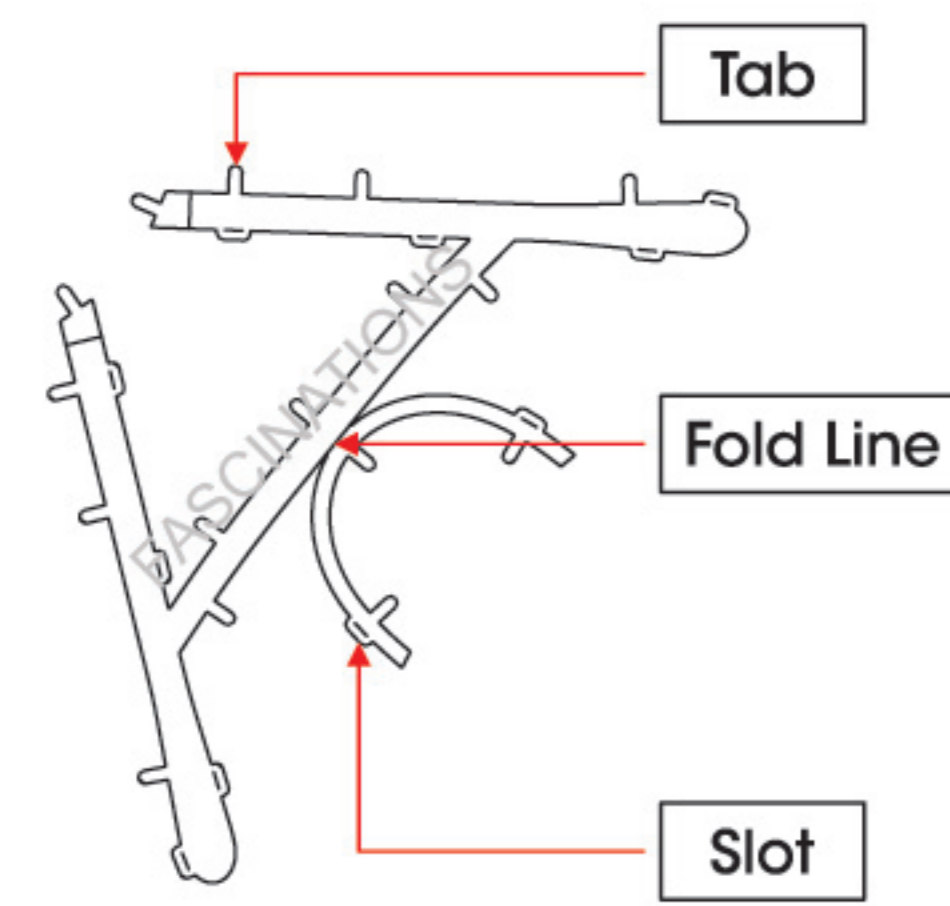

Legends:

- E** Engraved/ Color side
- NE** Non - engraved/ Silver side
- Attention point
- Insert tab and bend 90 degrees
- Insert tab and twist 90 degrees

Assembly tip:

If needed, slightly twist tabs to hold parts together then untwist and bend them down for a nice finish.

- Yellow areas should be curled
- Red areas should be folded

Recommended tools:

- Wire cutters: helpful for taking parts from the metal sheets.



- Tweezers or needle nose pliers: helpful for folding parts, bending and twisting tabs.

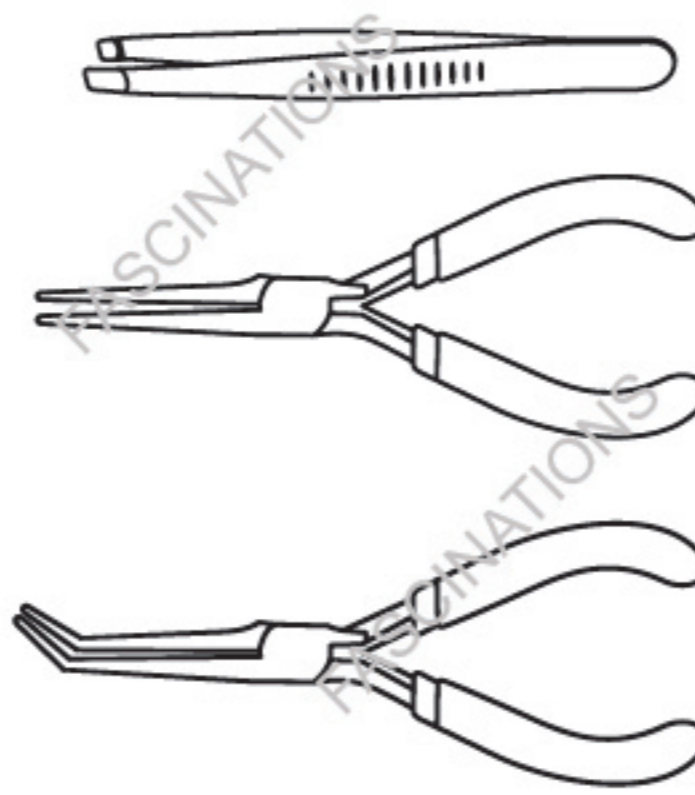

METAL SHEETS

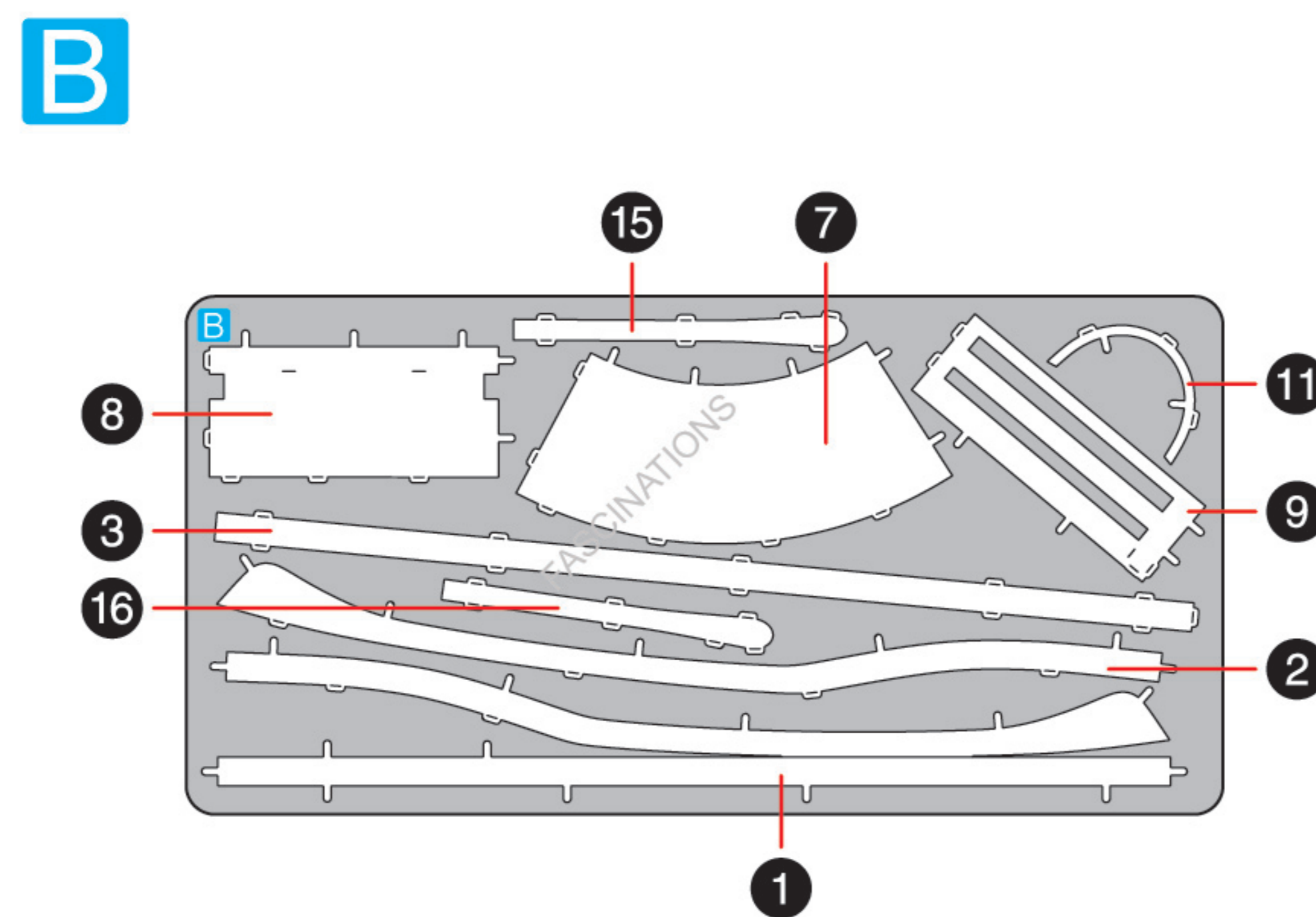
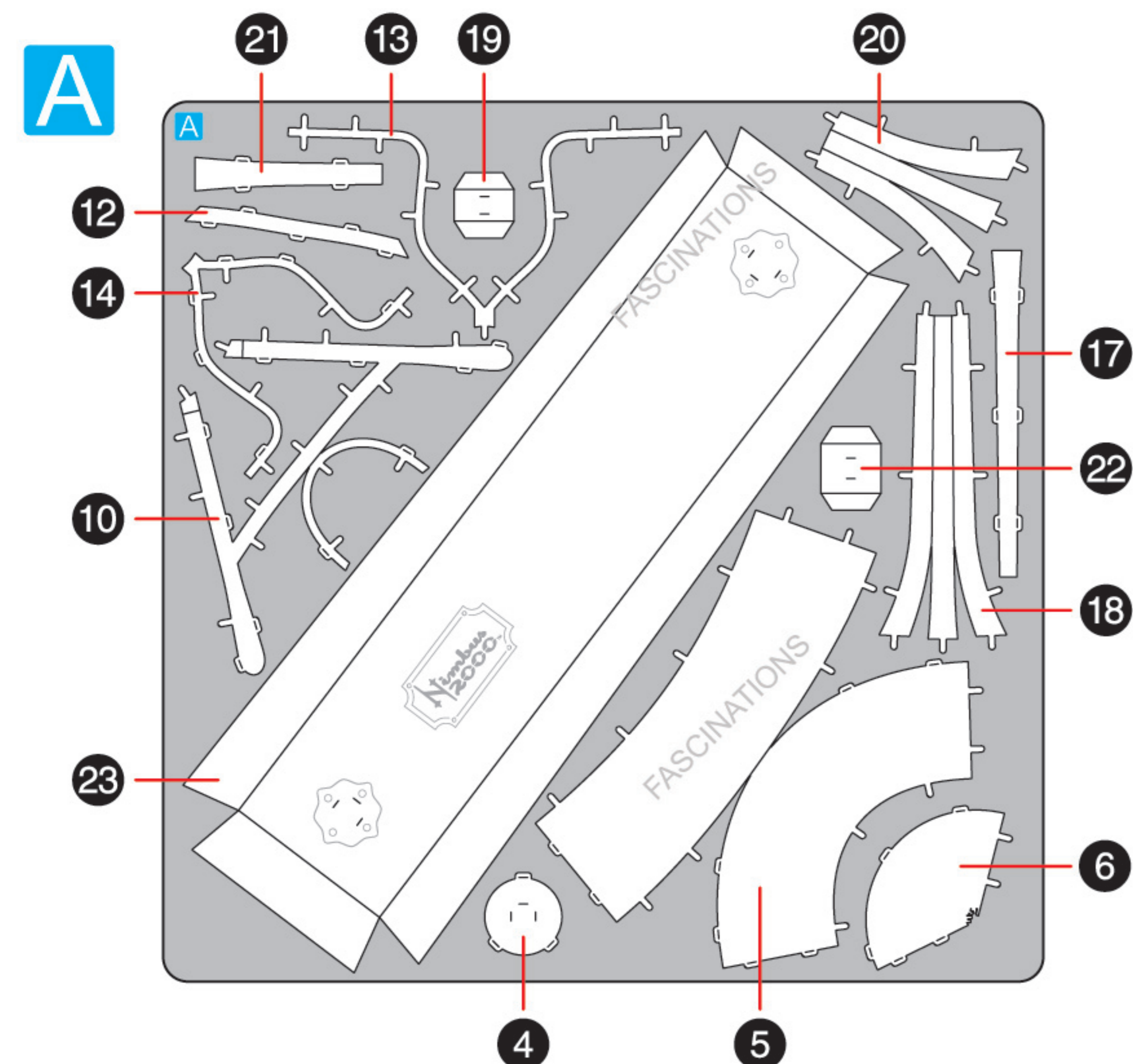

In order to avoid possible injury from sharp edges, please carefully discard the metal sheets after parts have been removed.

ASSEMBLY FLOW CHART

Step 1

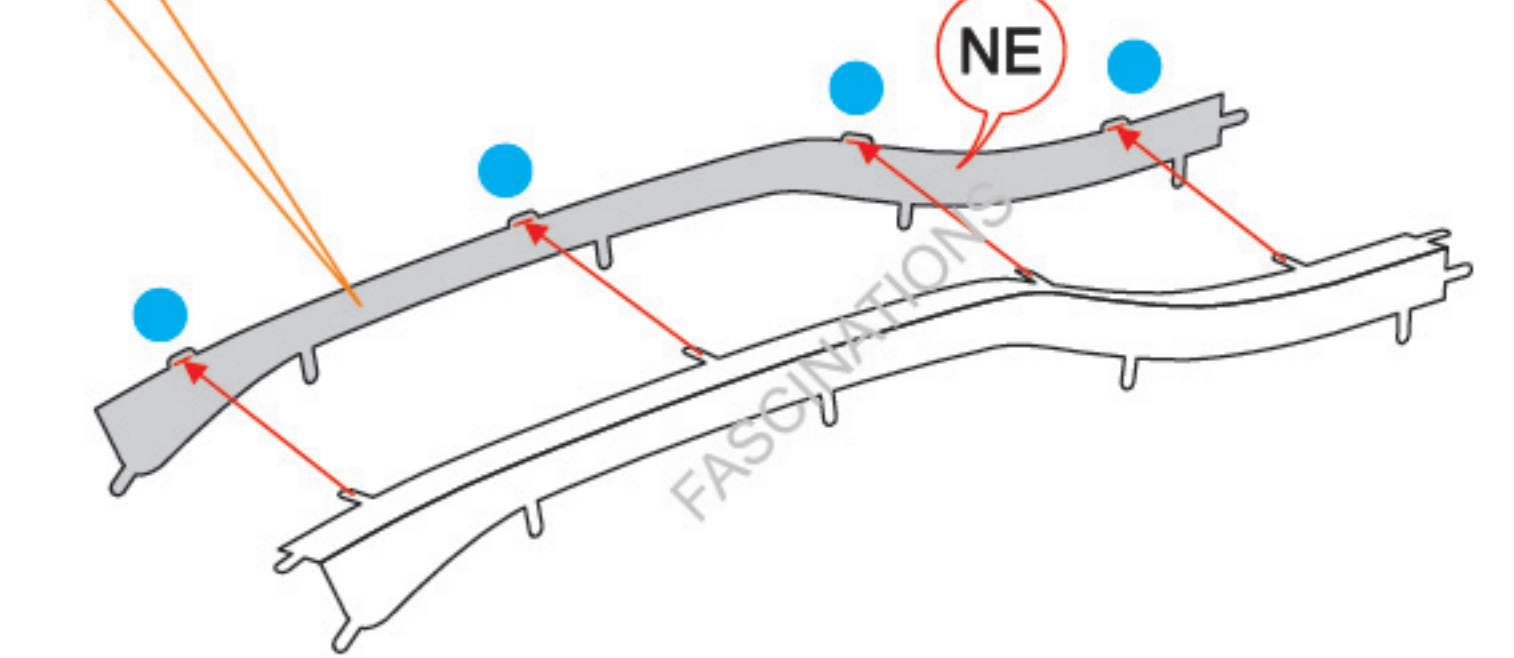
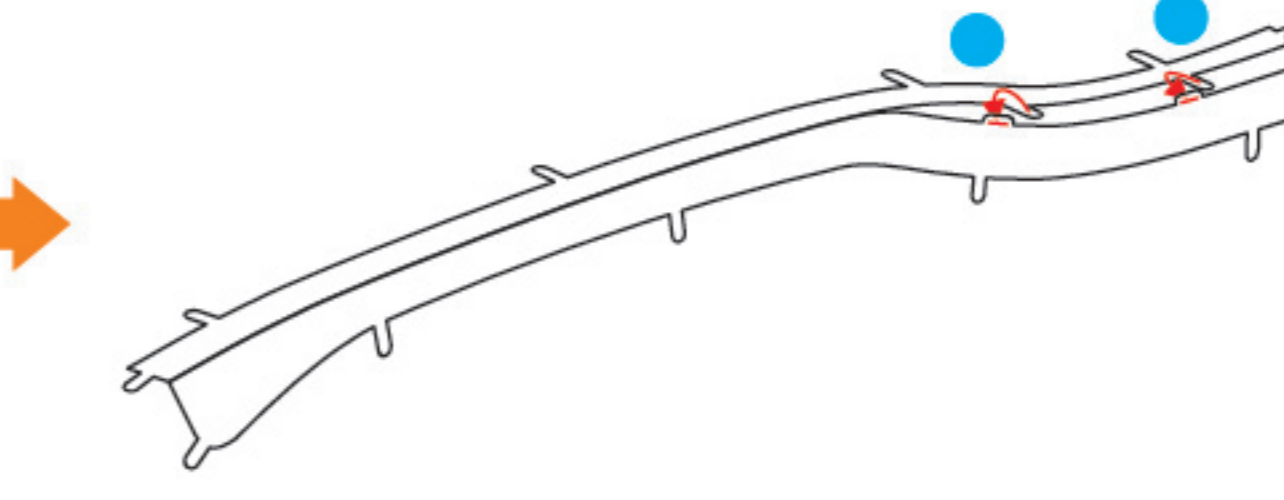
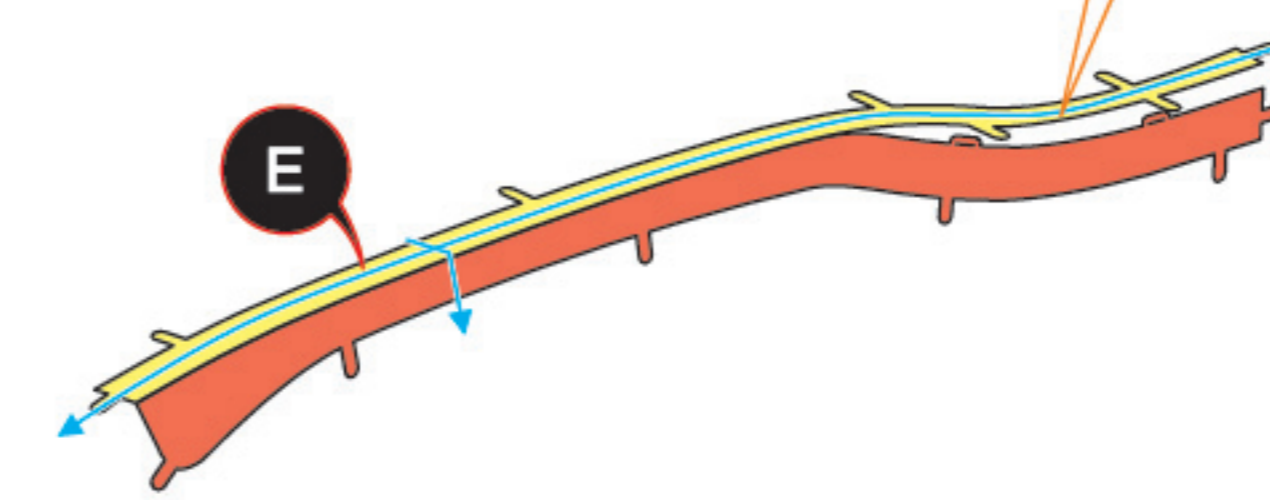
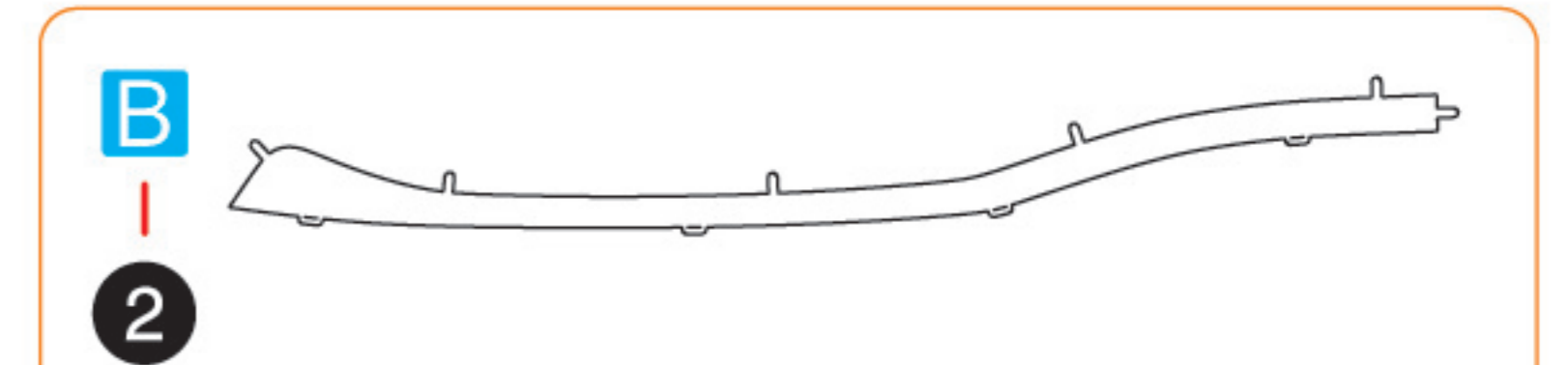
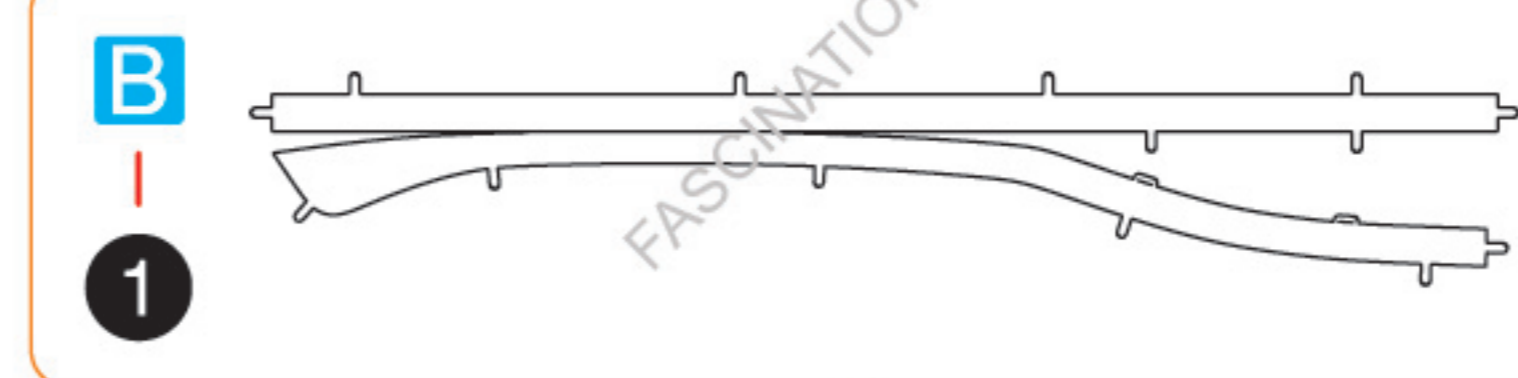

Connect the tabs illustrated in red first

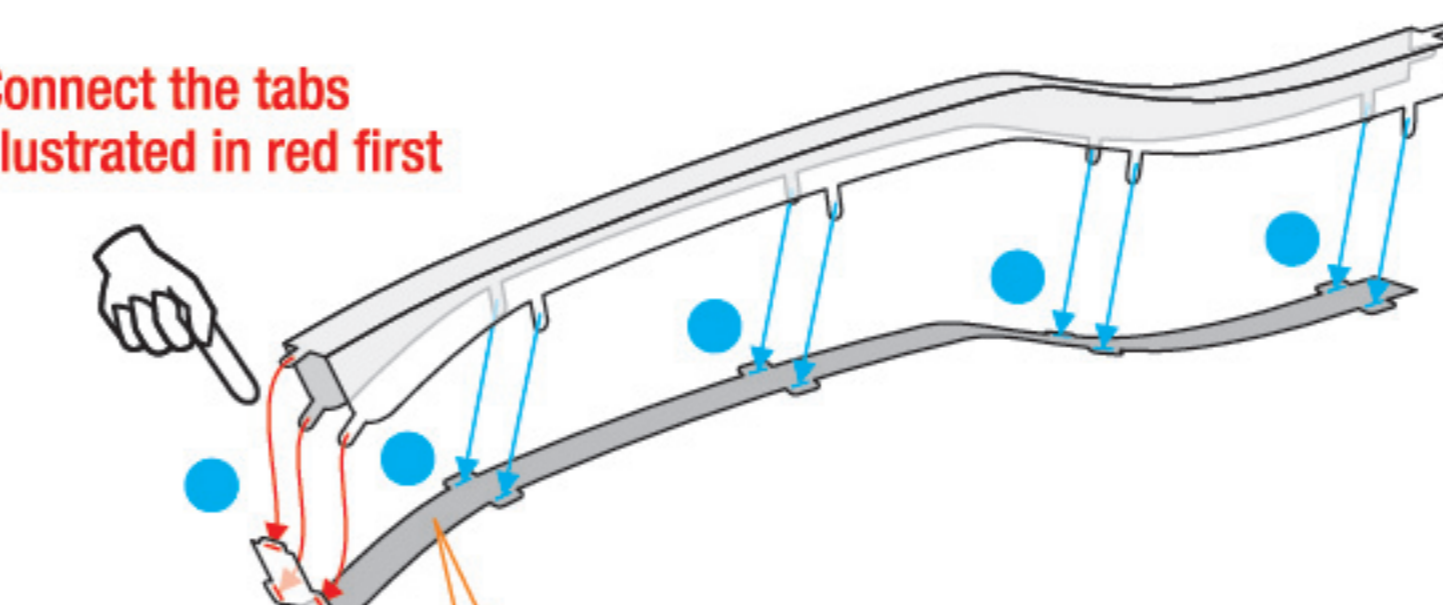

B-3

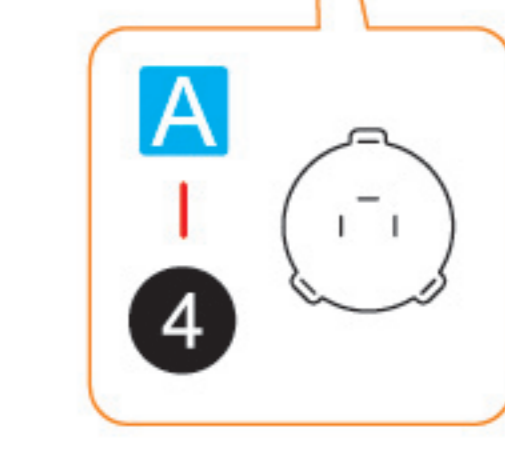
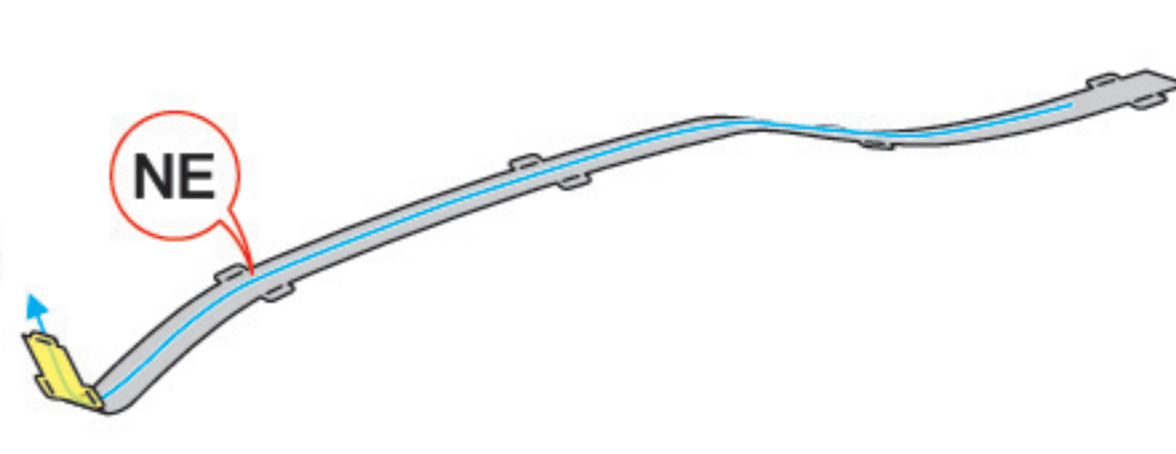
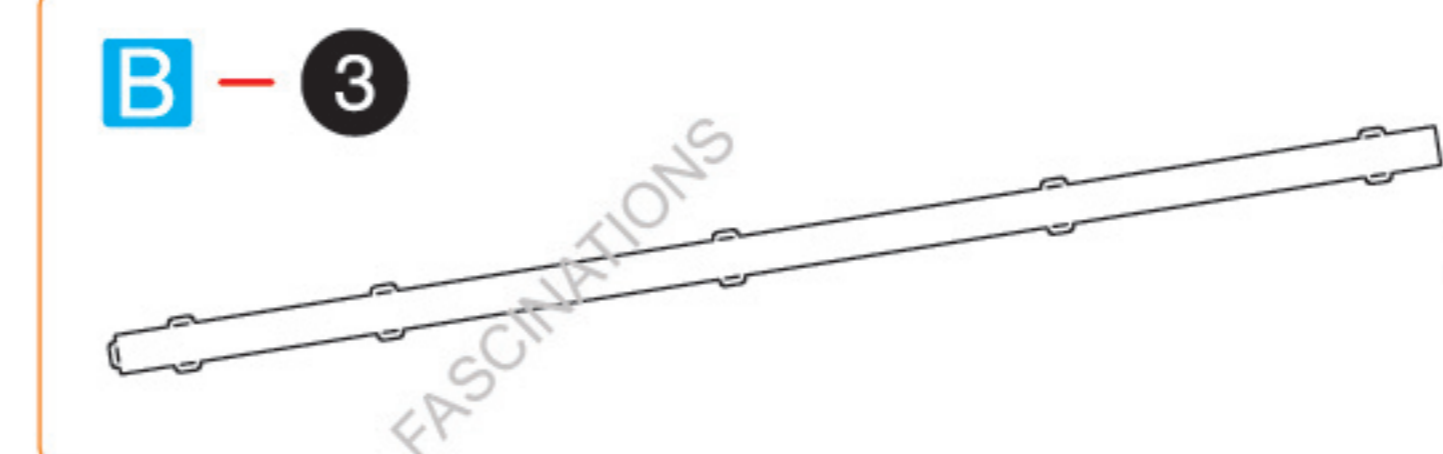

Step 2

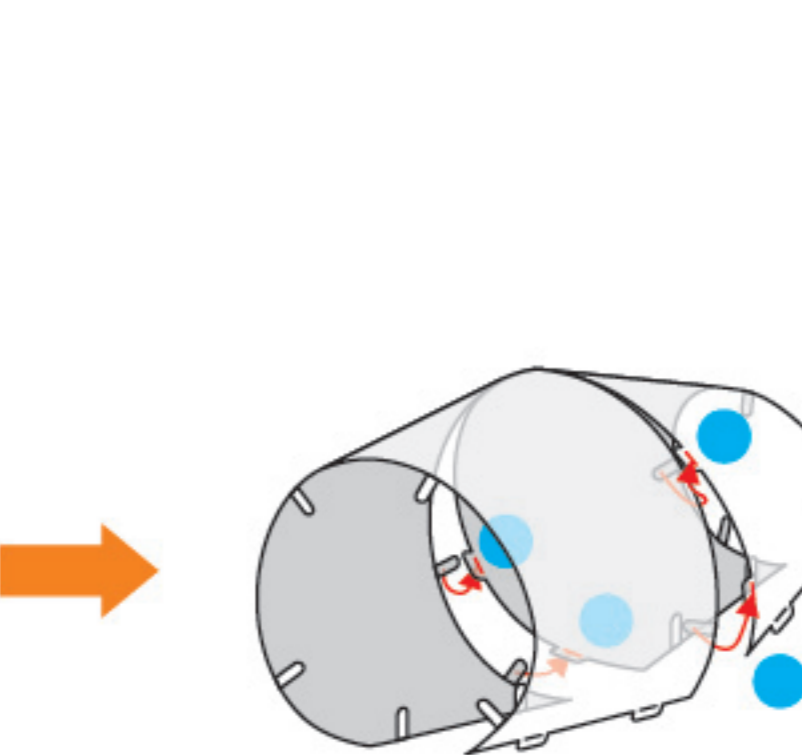
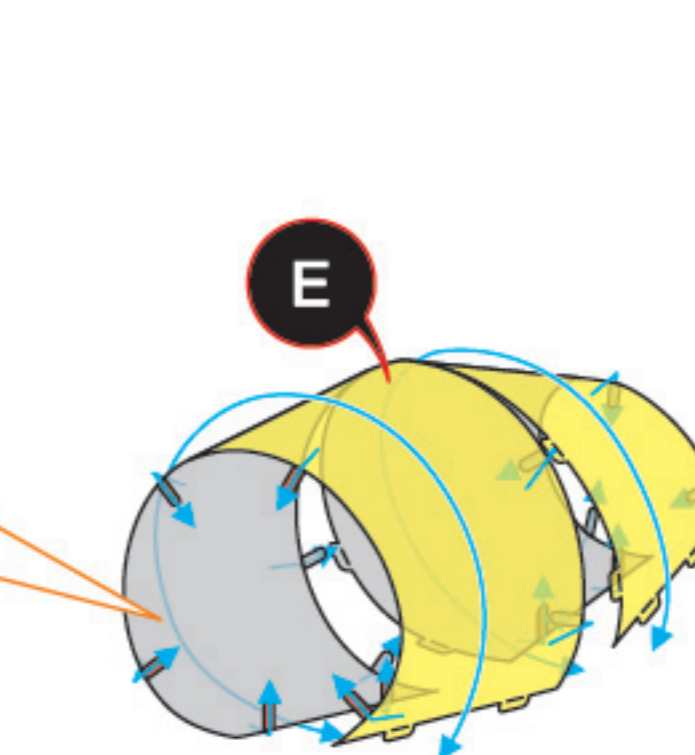
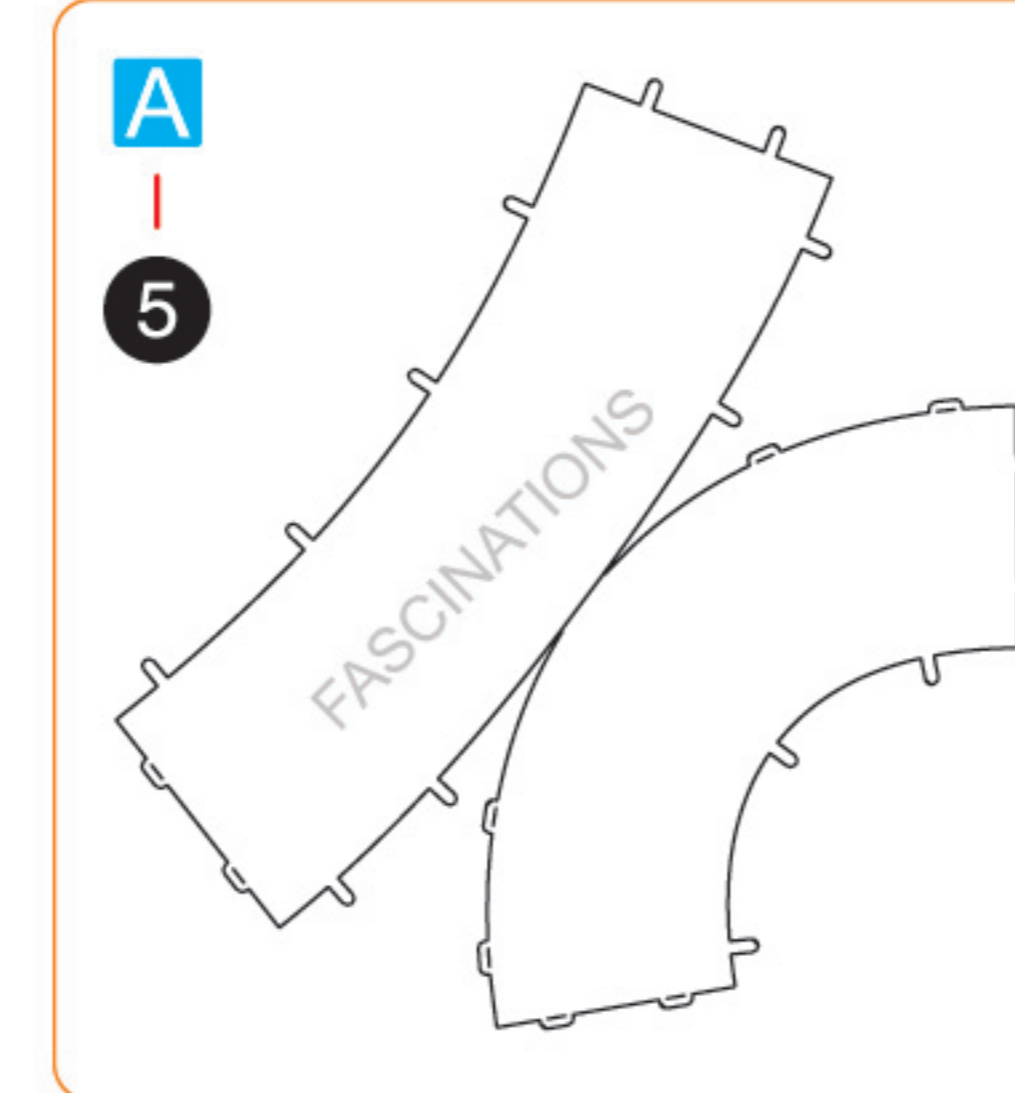

Connect the tabs illustrated in red first

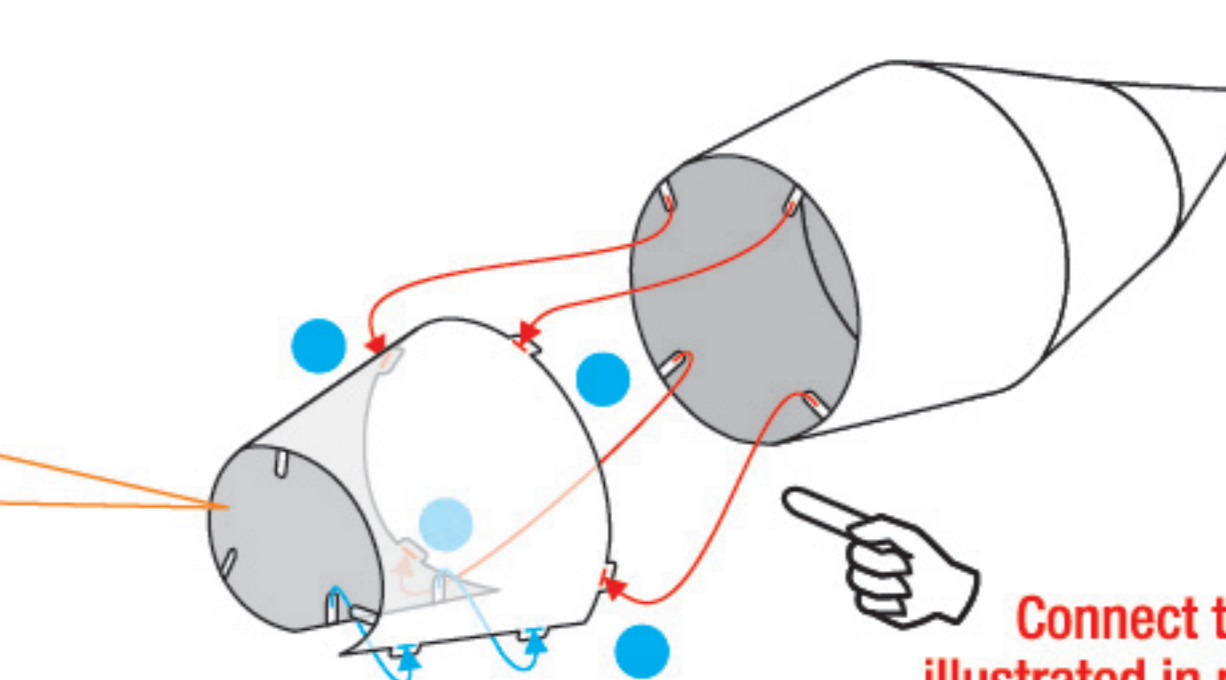
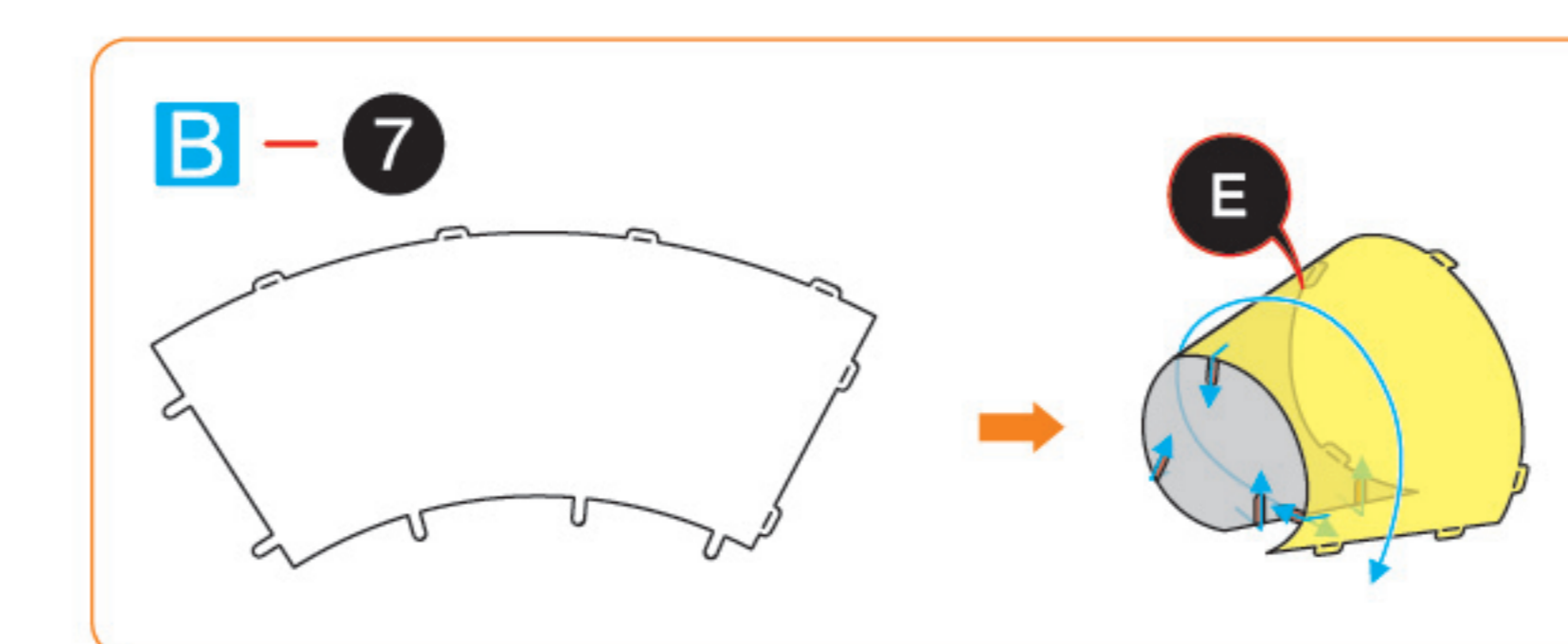
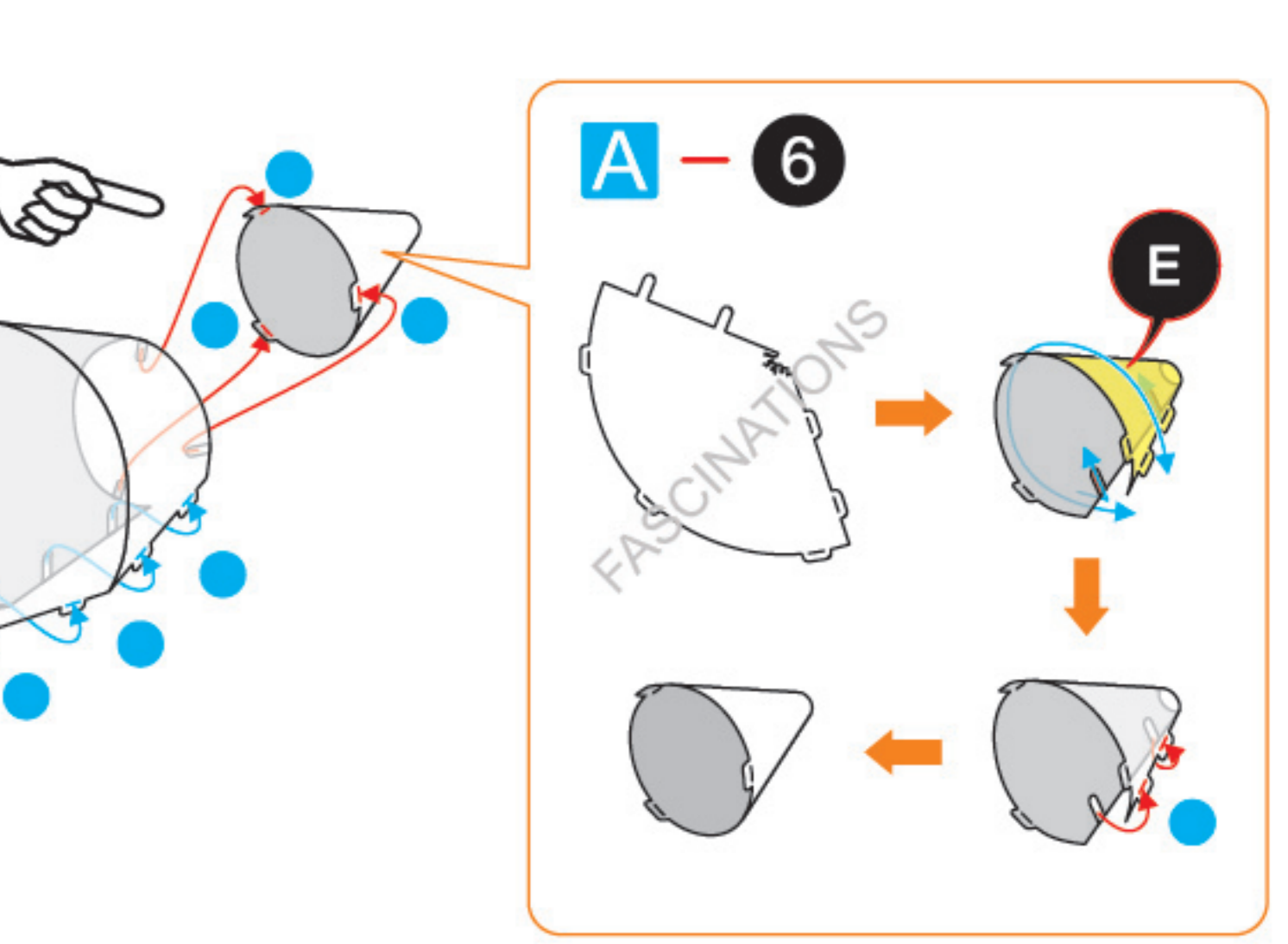

Connect the tabs illustrated in red first

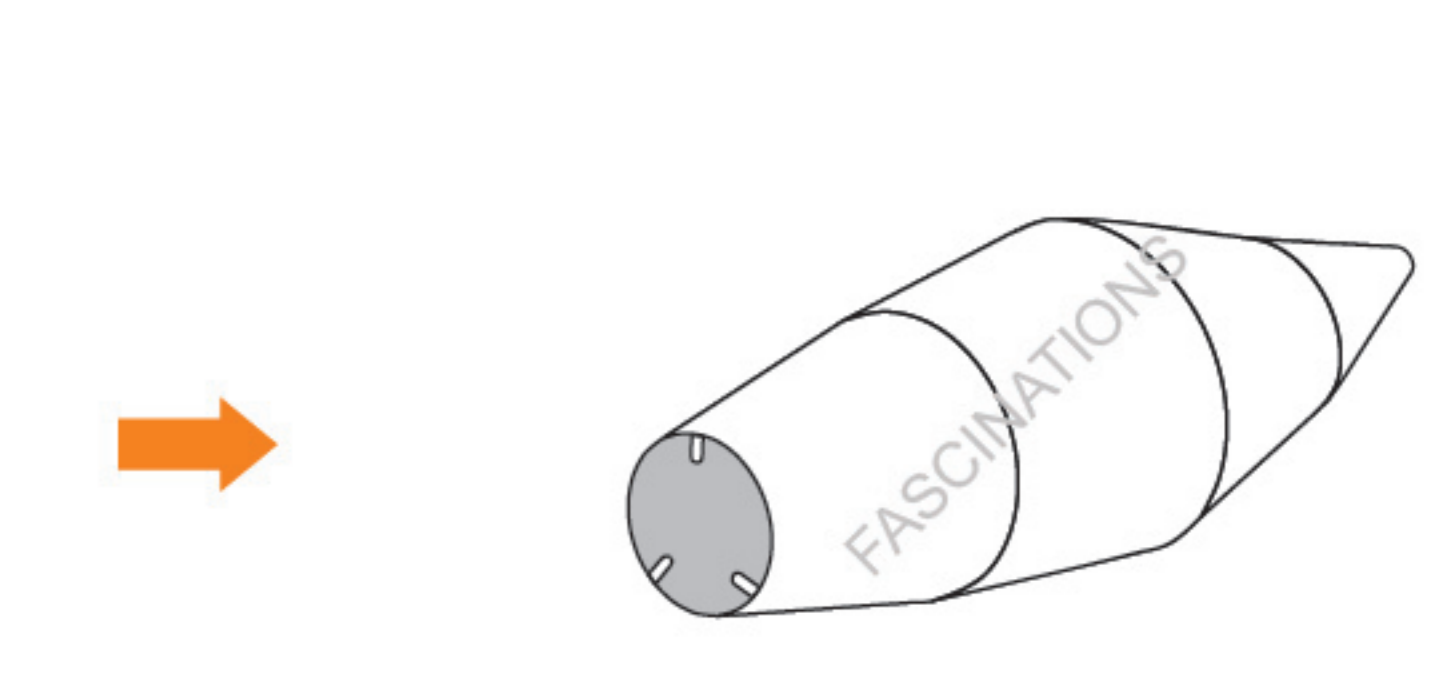

Step 3

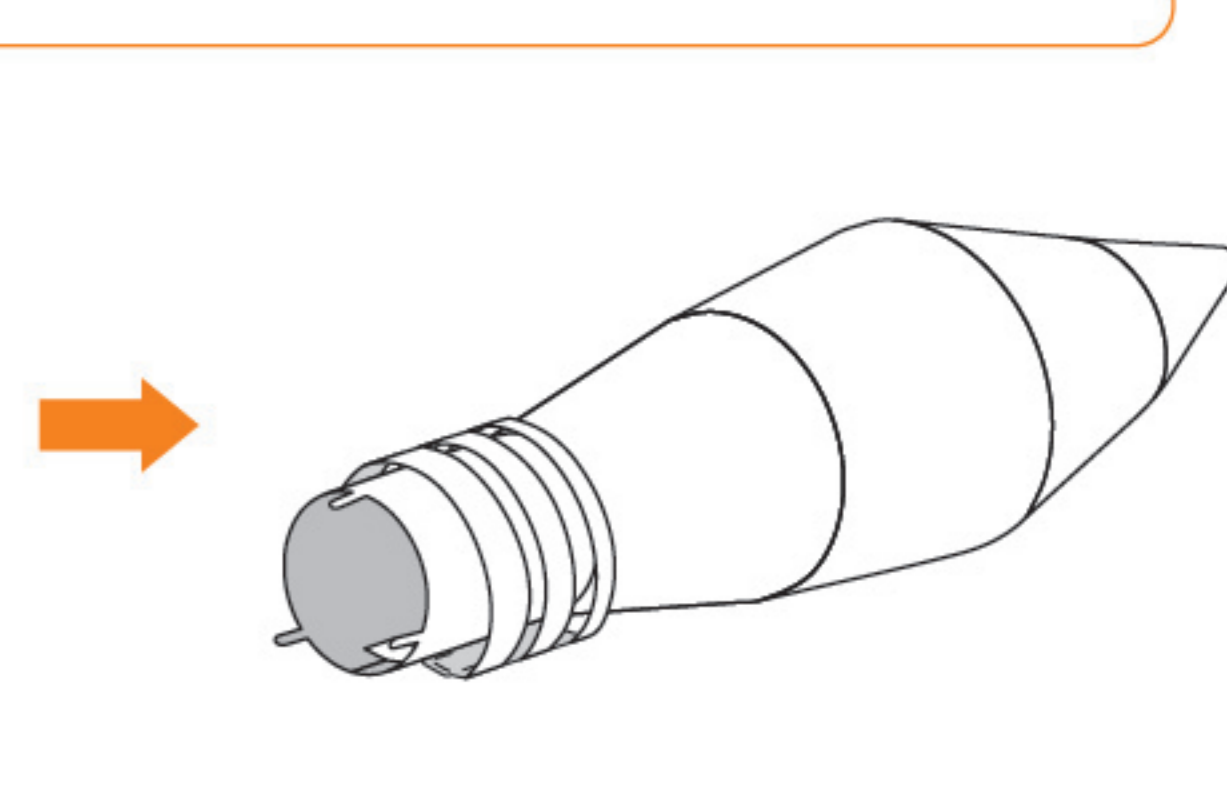
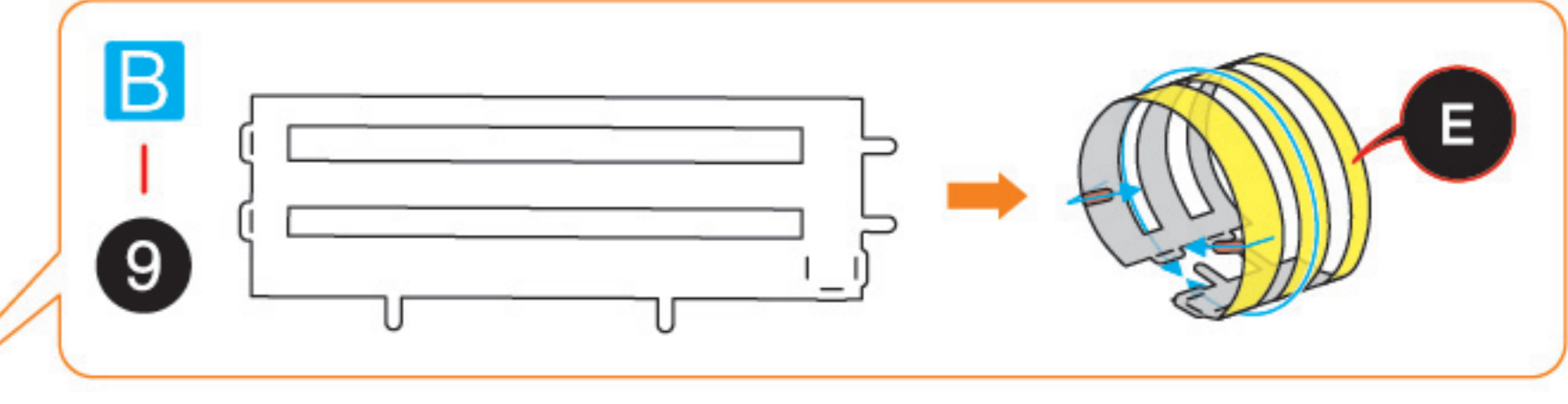
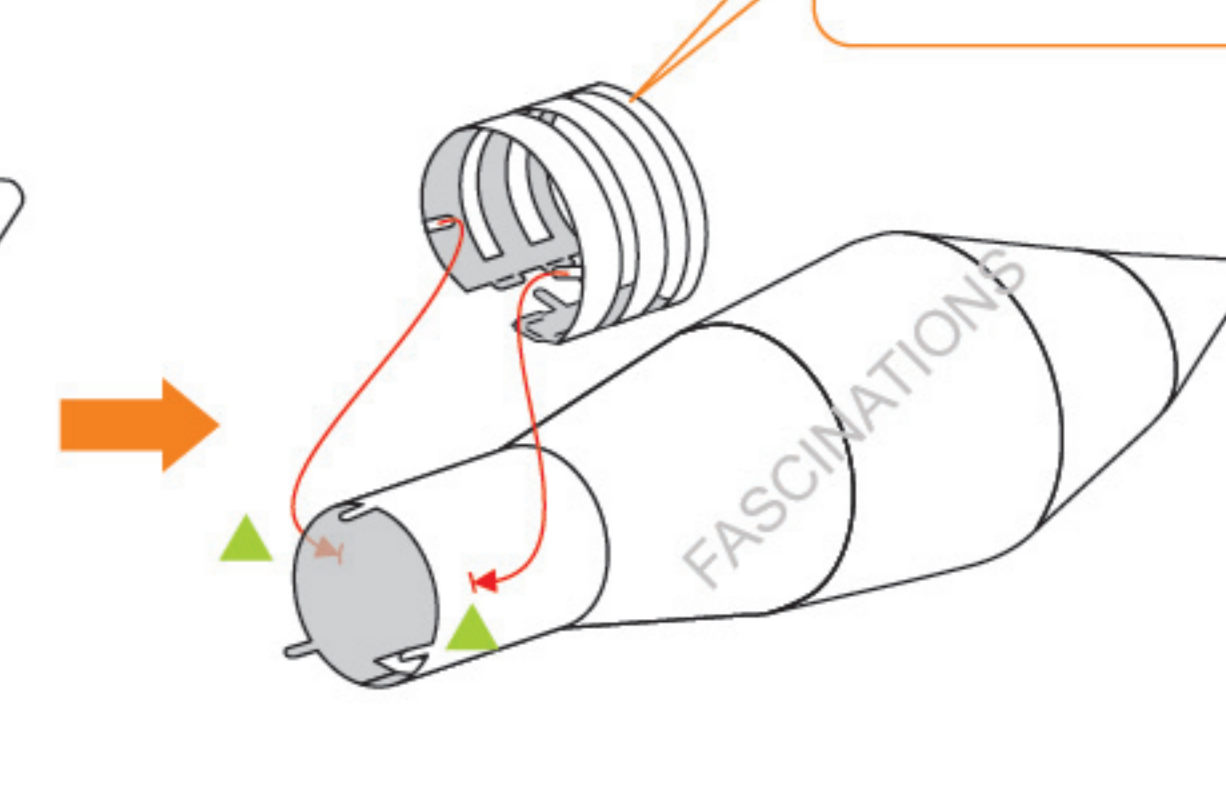
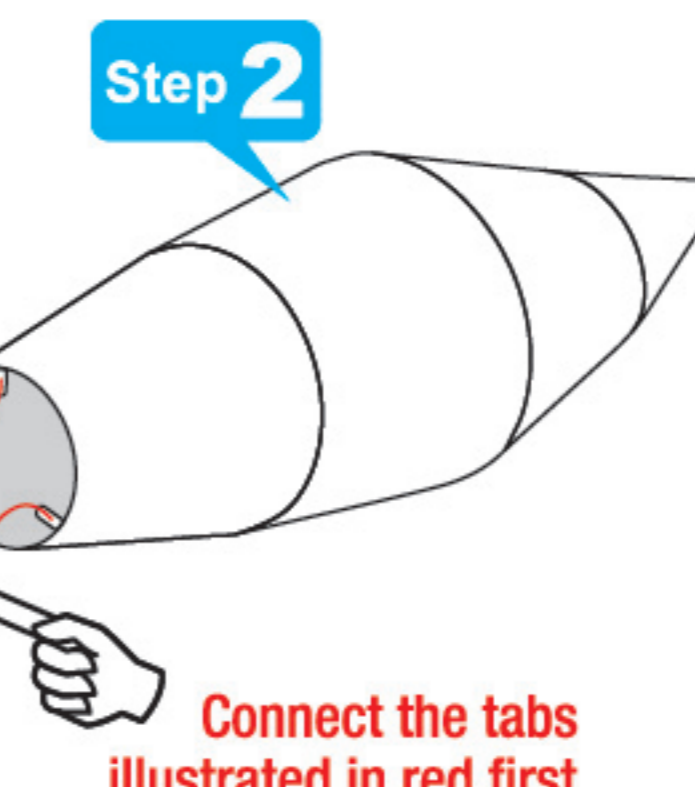
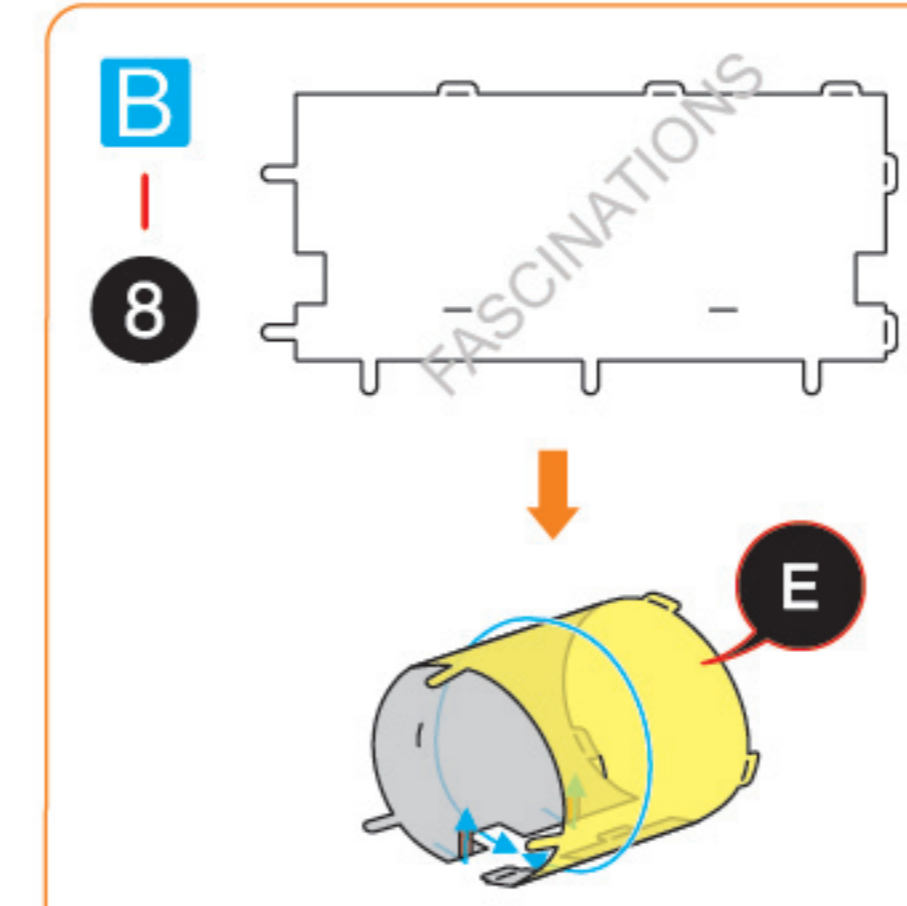

Step 4 Tips: Look through the assembly flow before you start

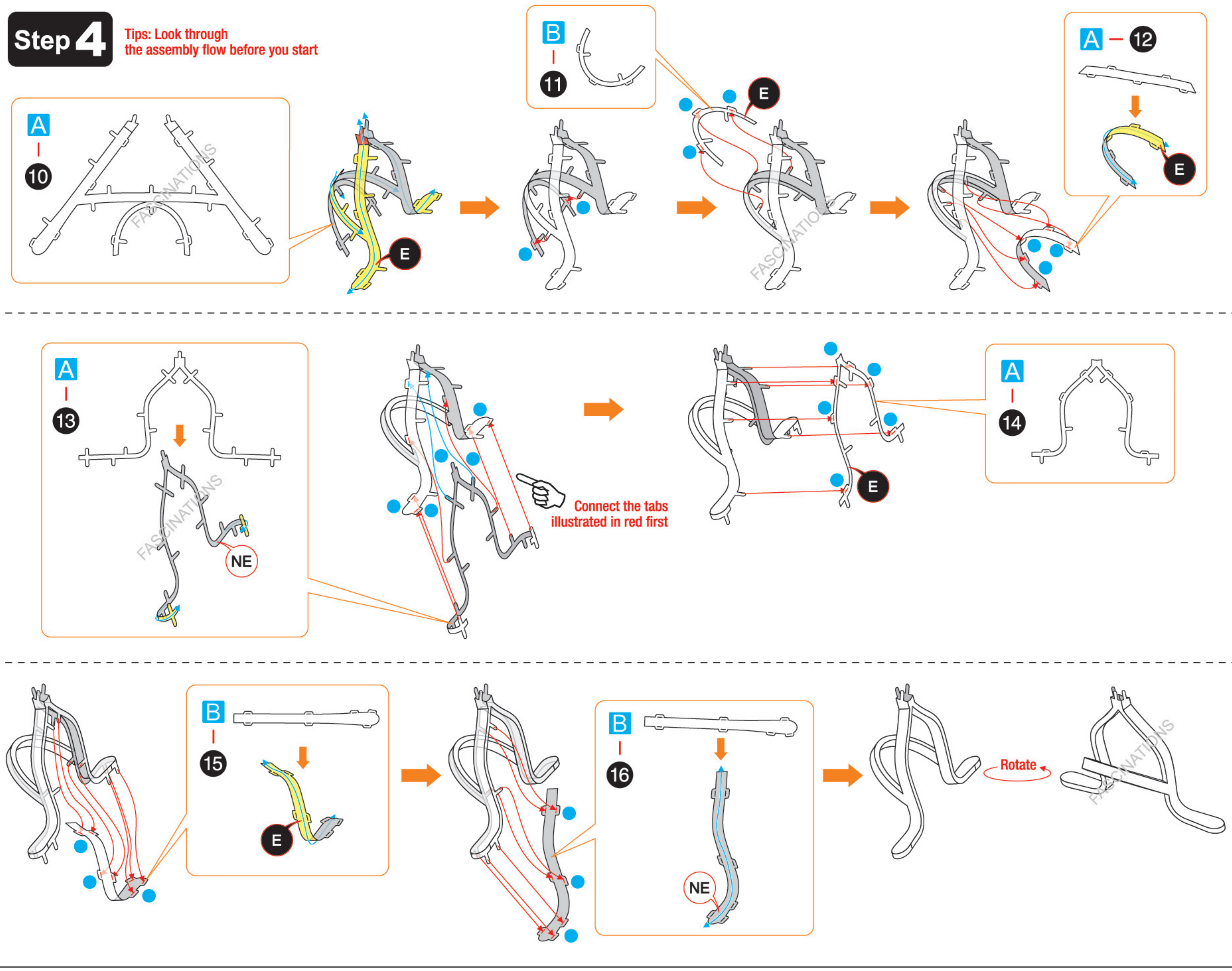

Step 5

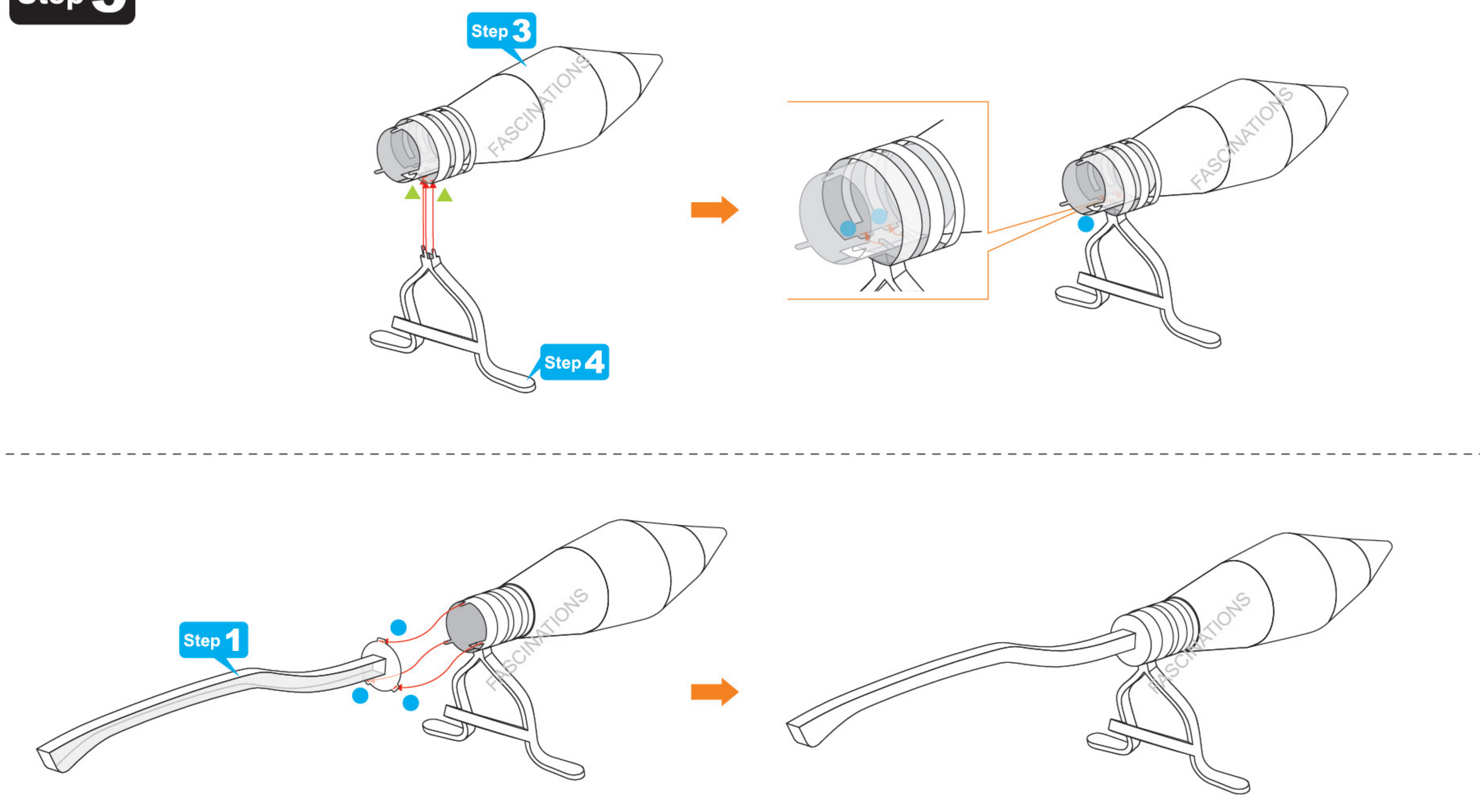

Step 6

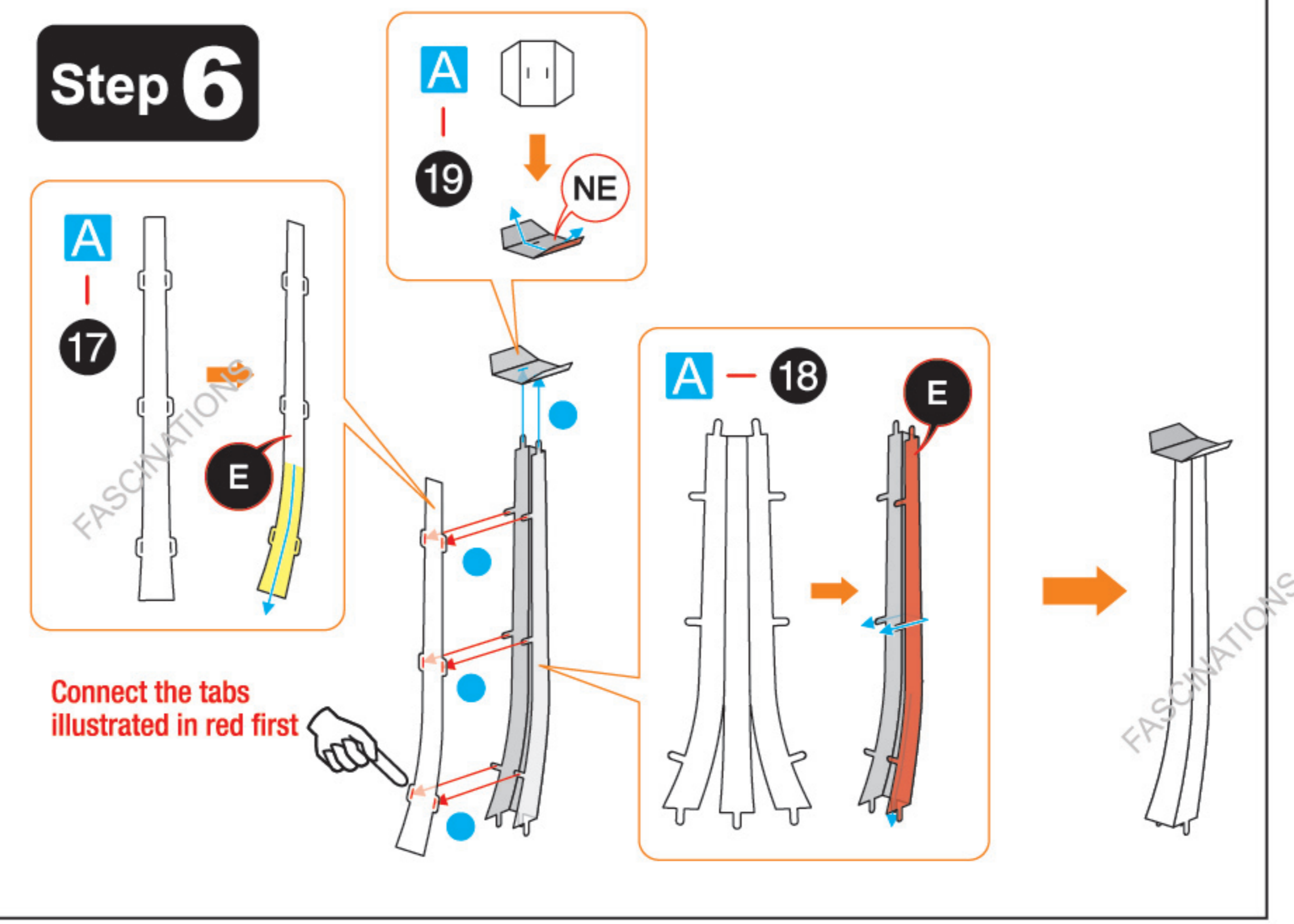

Step 7

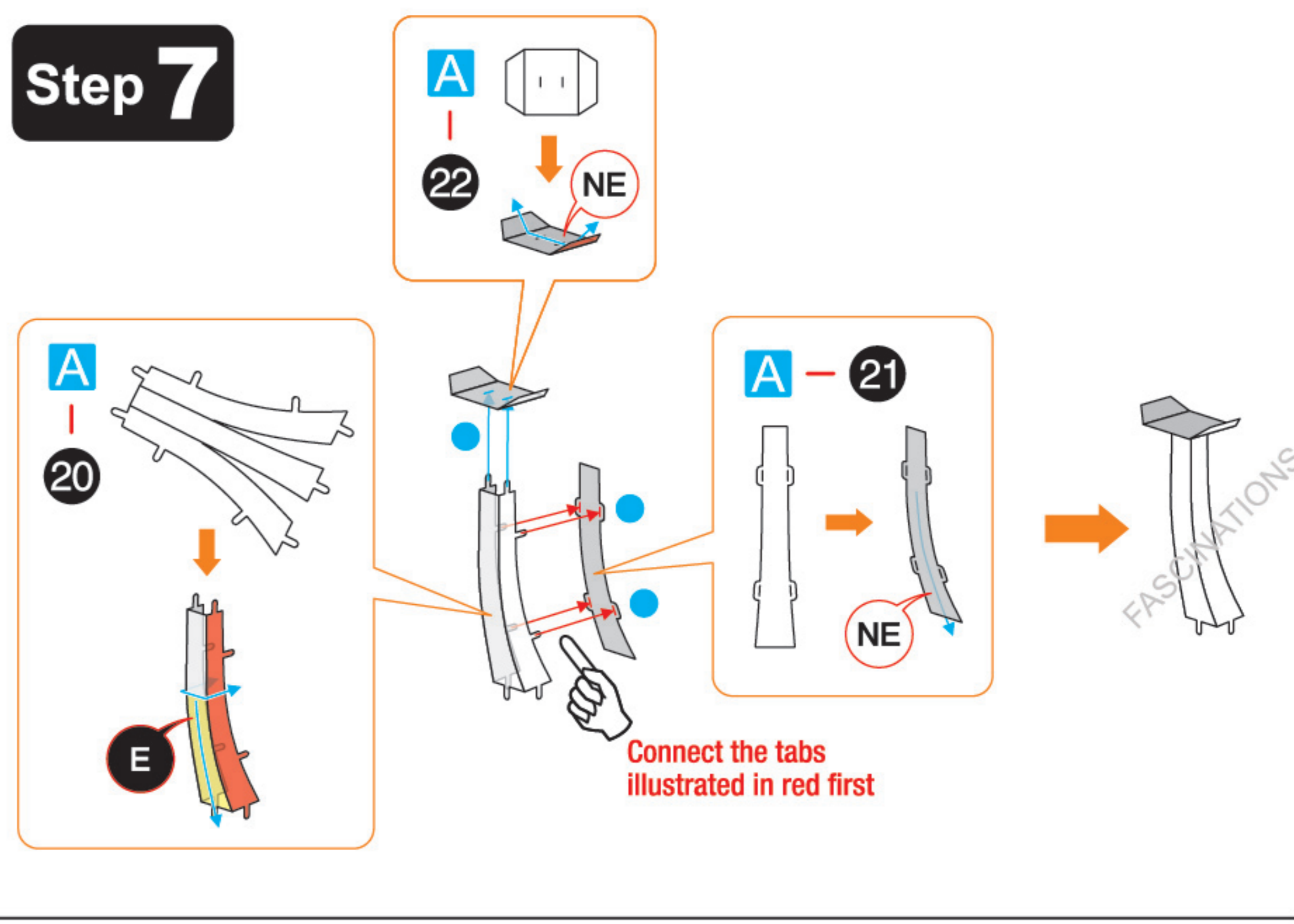

Step 8

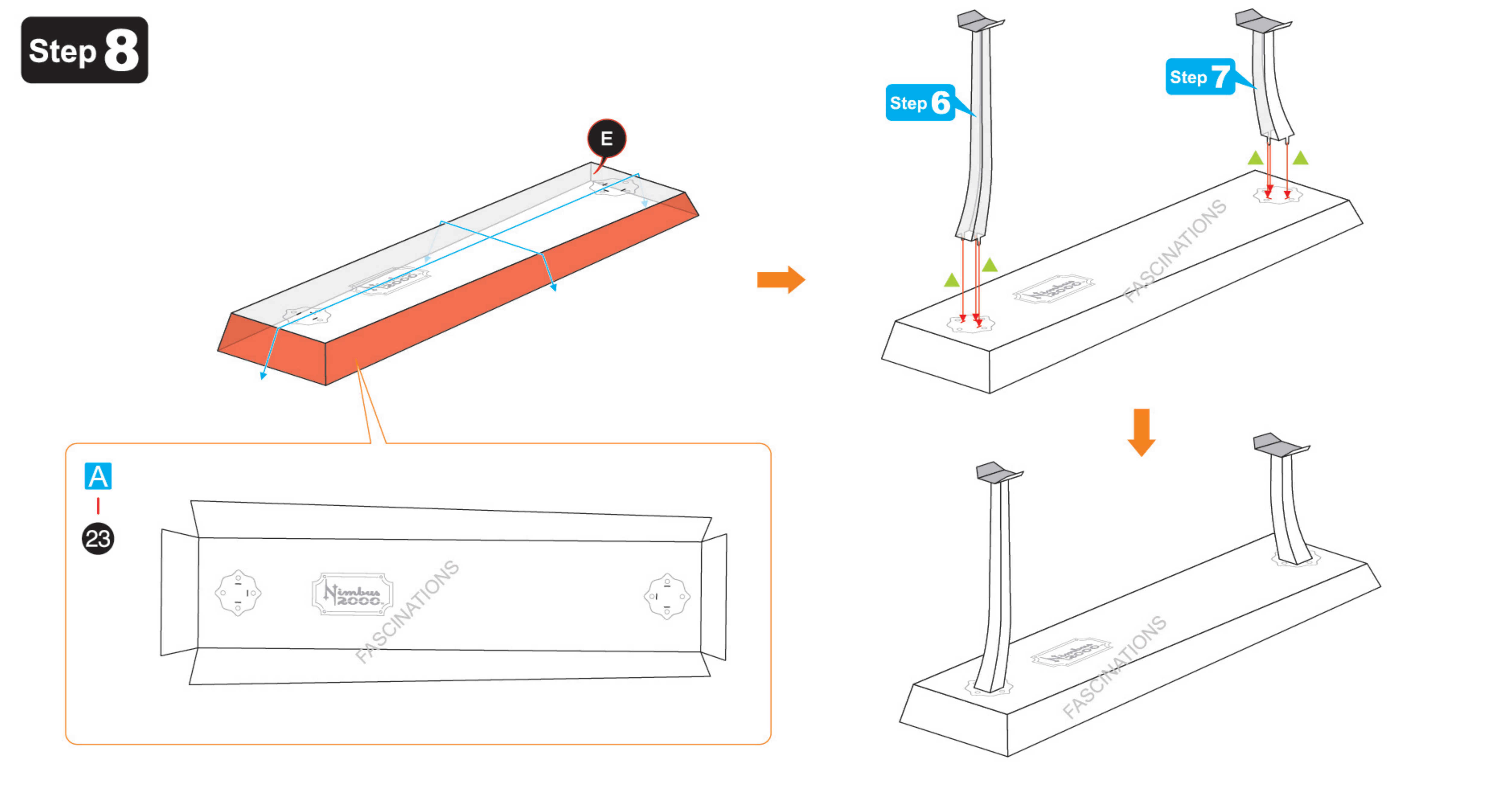

Step 9

