

Space Shuttle Atlantis  
Item No. MMS015



It is highly recommended that you visit [www.metalearth.com/360/mms015](http://www.metalearth.com/360/mms015) to see the completed model before assembling your own

**Legends:**

- Engraved side
- Non-engraved side
- Attention point
- Insert tab and bend 90 degrees
- Insert tab and twist 90 degrees

**Assembly tip:**

If needed, slightly twist tabs to hold parts together then untwist and bend them down for a nice finish

**Recommended tools:**

-Wire cutters: helpful for taking parts from the metal sheets.



-Tweezers or needle nose pliers: helpful for folding parts, bending and twisting tabs.

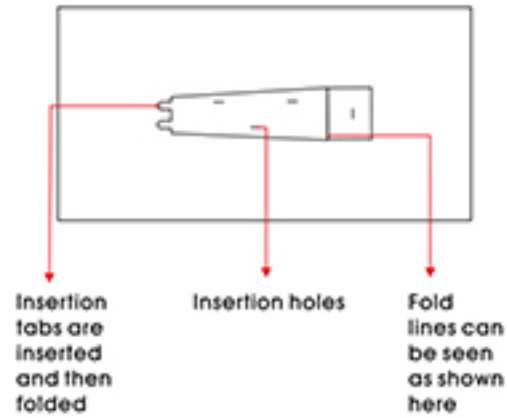

**Metal sheet**

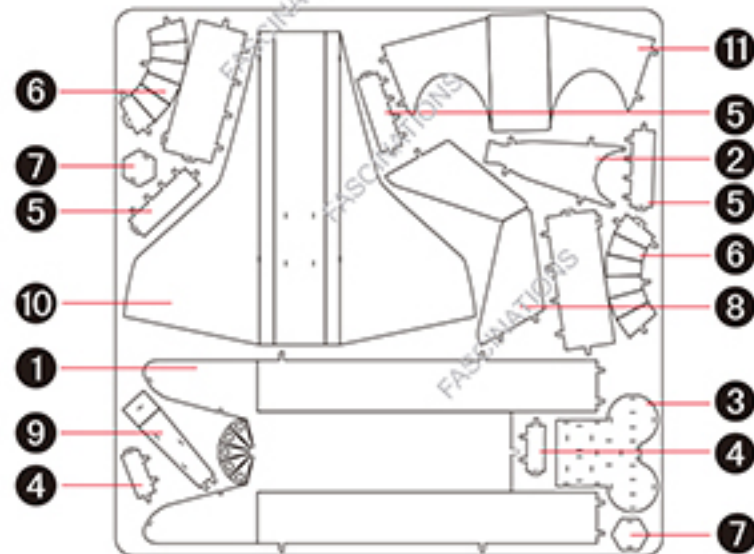

In order to avoid possible injury from sharp edges, please carefully discard the metal sheet after parts have been removed

## Assembly Flow Chart

