



Brandenburg Gate
Item No. MMS025



It is highly recommended that you visit www.metalearth.com/360/mms025 to see the completed model before assembling your own

Legends:

- Engraved side
- Non-engraved side
- Attention point
- Insert tab and bend 90 degrees
- Insert tab and twist 90 degrees

Recommended tools:

-Wire cutters: helpful for taking parts from the metal sheets.



-Tweezers or needle nose pliers: helpful for folding parts, bending and twisting tabs.

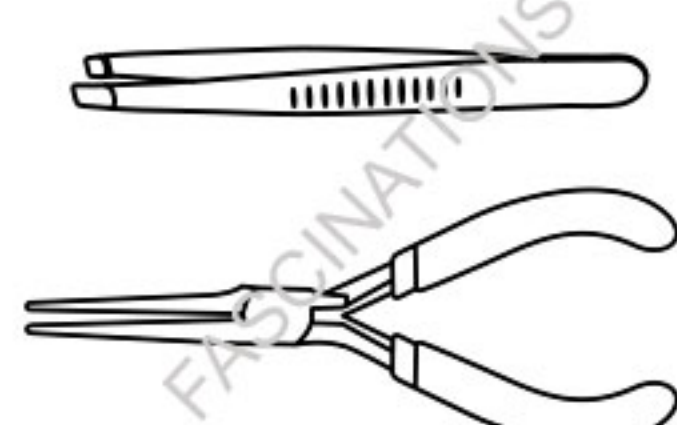

Assembly tip:

If needed, slightly twist tabs to hold parts together then untwist and bend them down for a nice finish

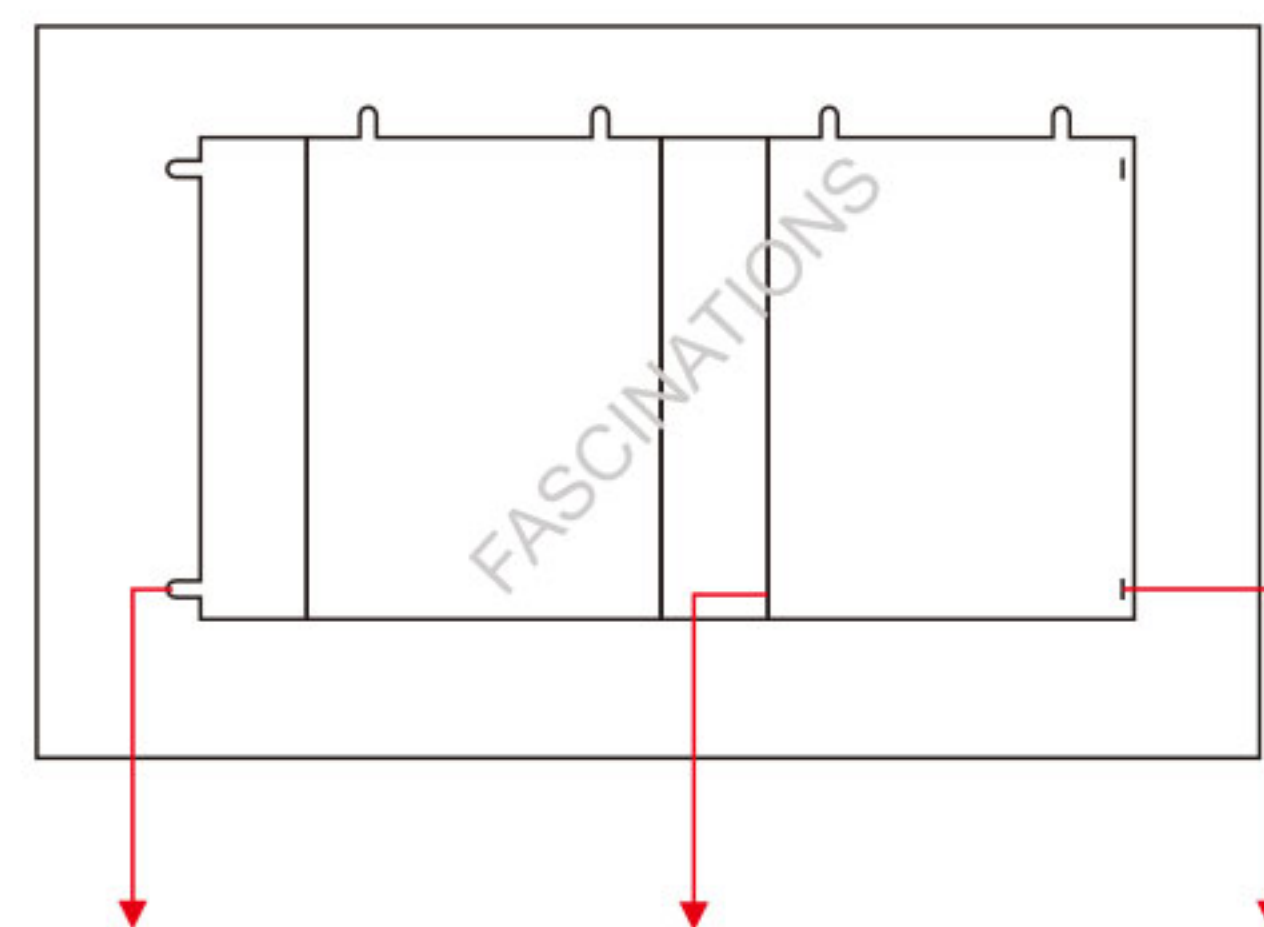

Insertion tabs are inserted and then folded
Fold lines can be seen as shown here
Insertion holes

Metal sheets

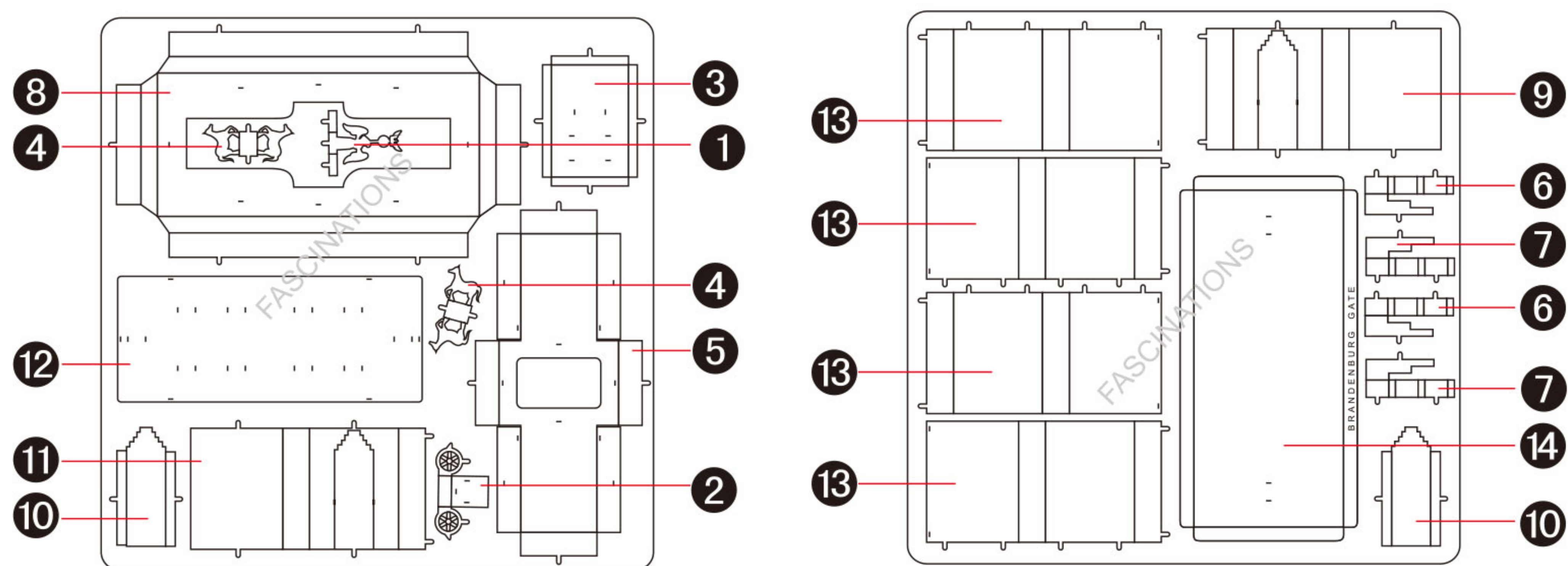

In order to avoid possible injury from sharp edges, please carefully discard the metal sheets after parts have been removed

Assembly Flow Chart

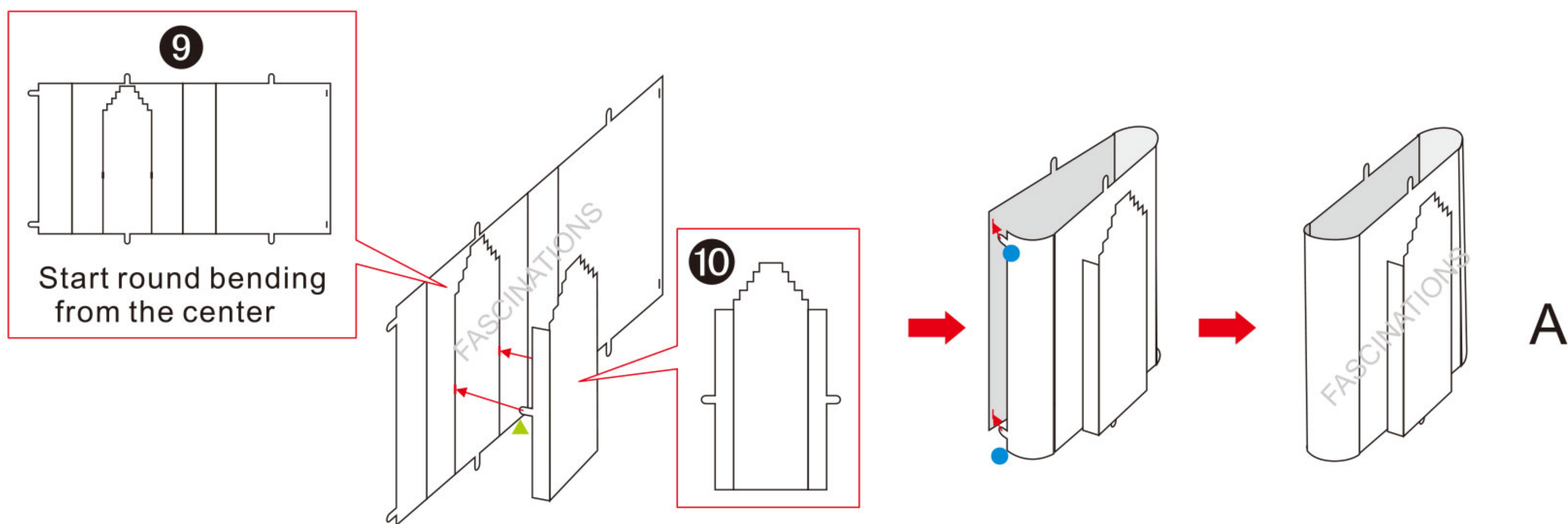
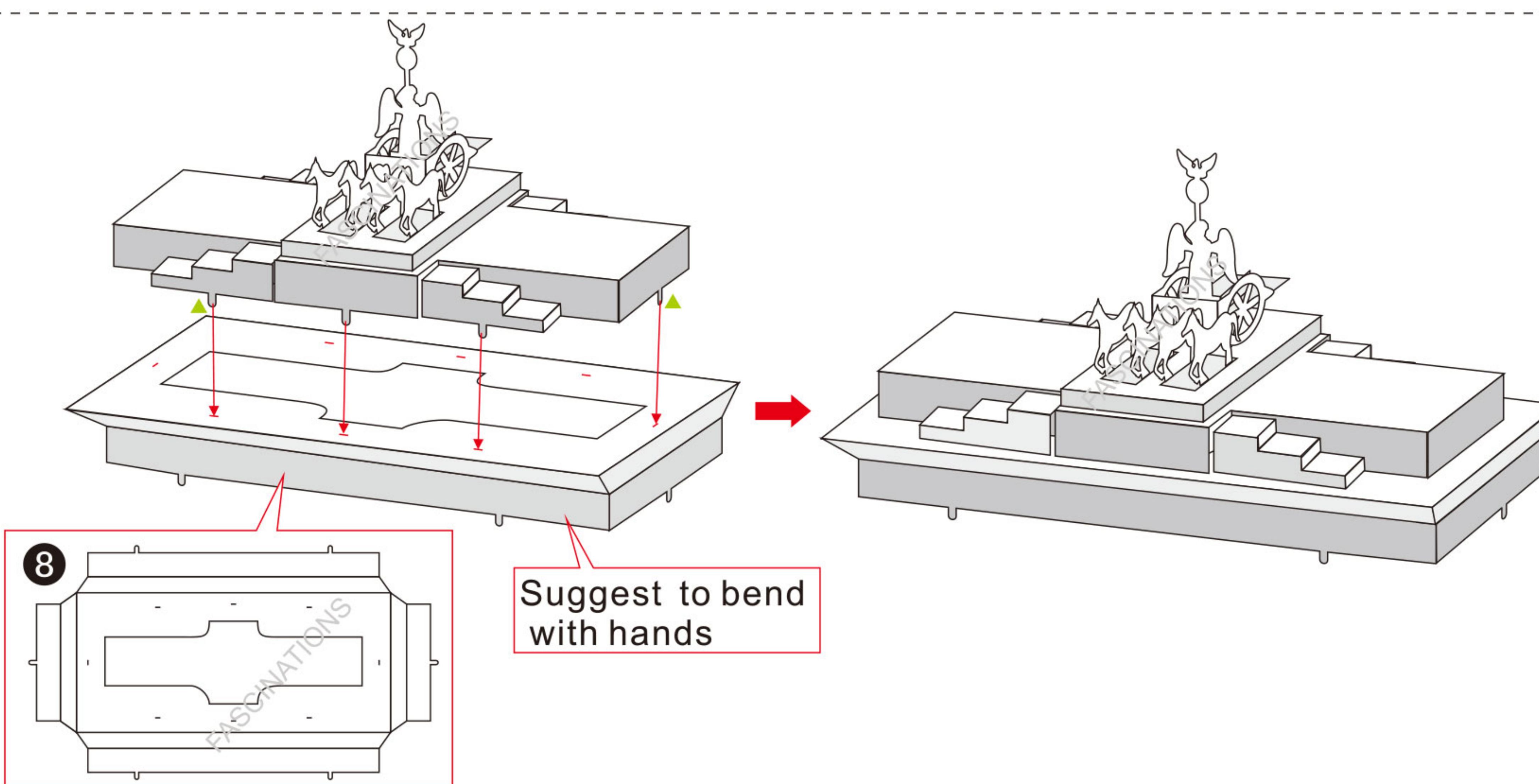
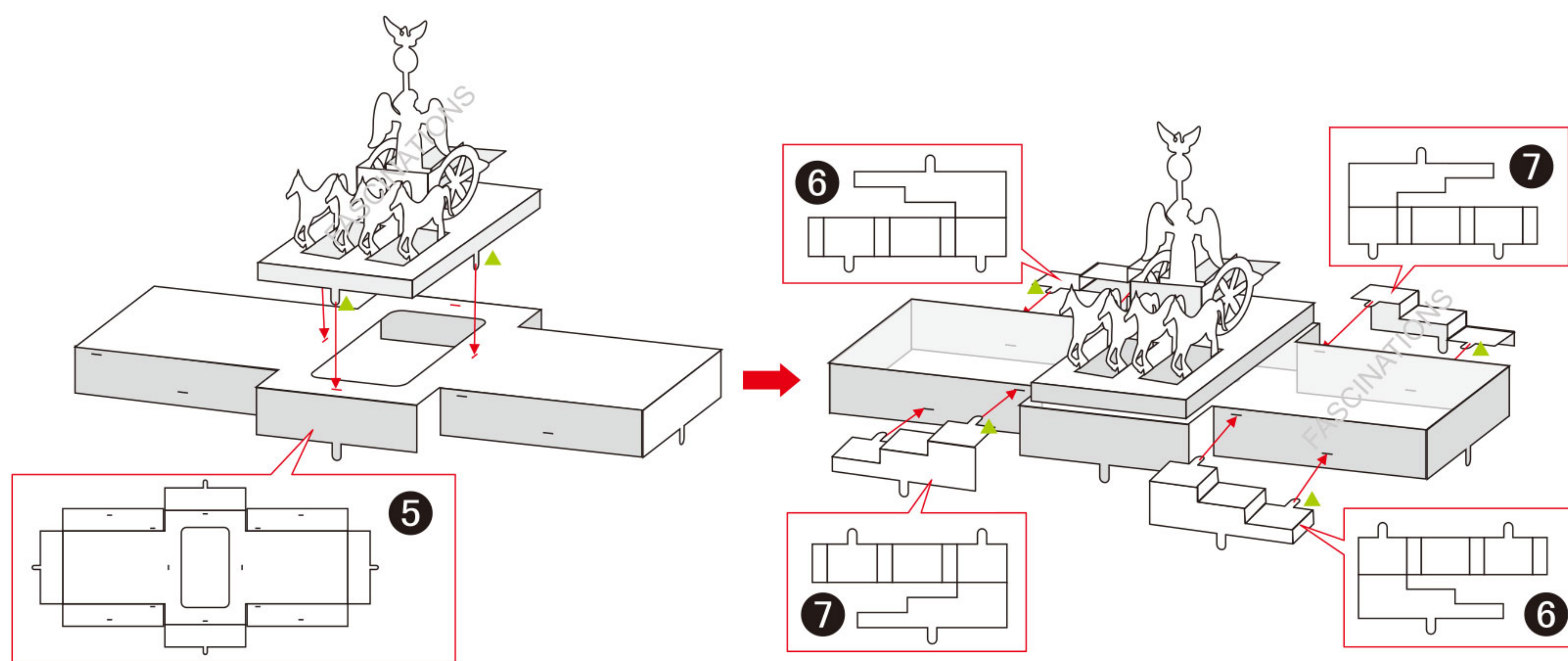
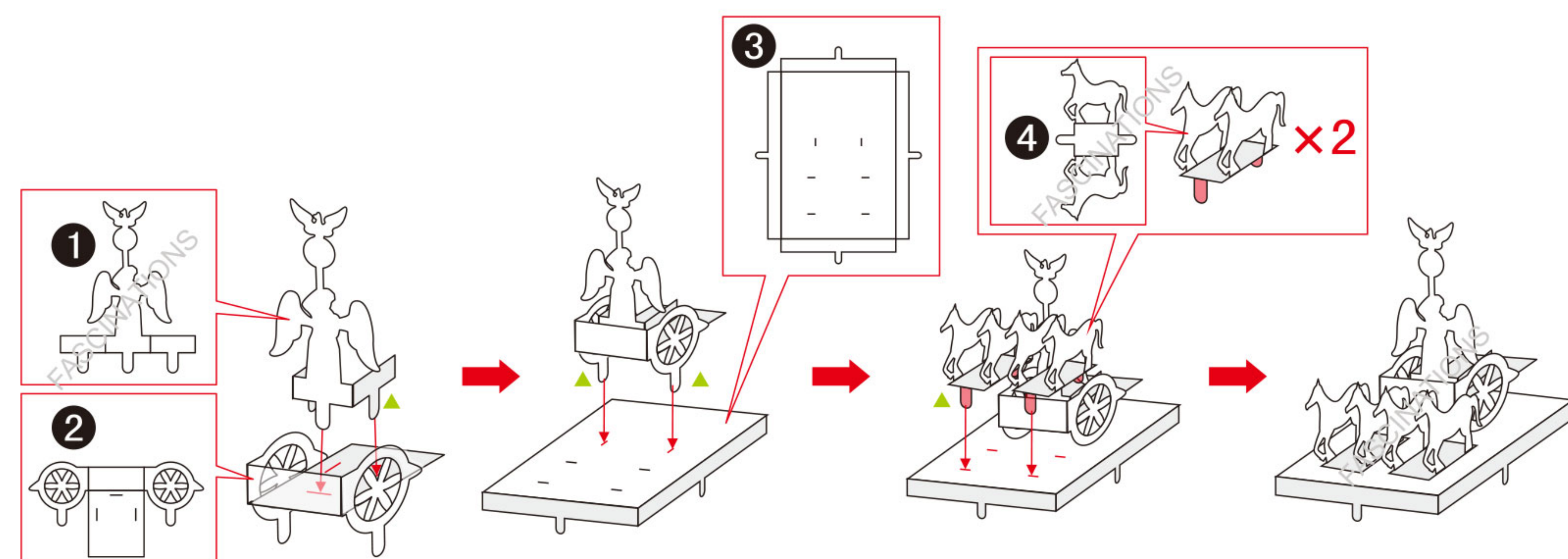

Start round bending from the center

A

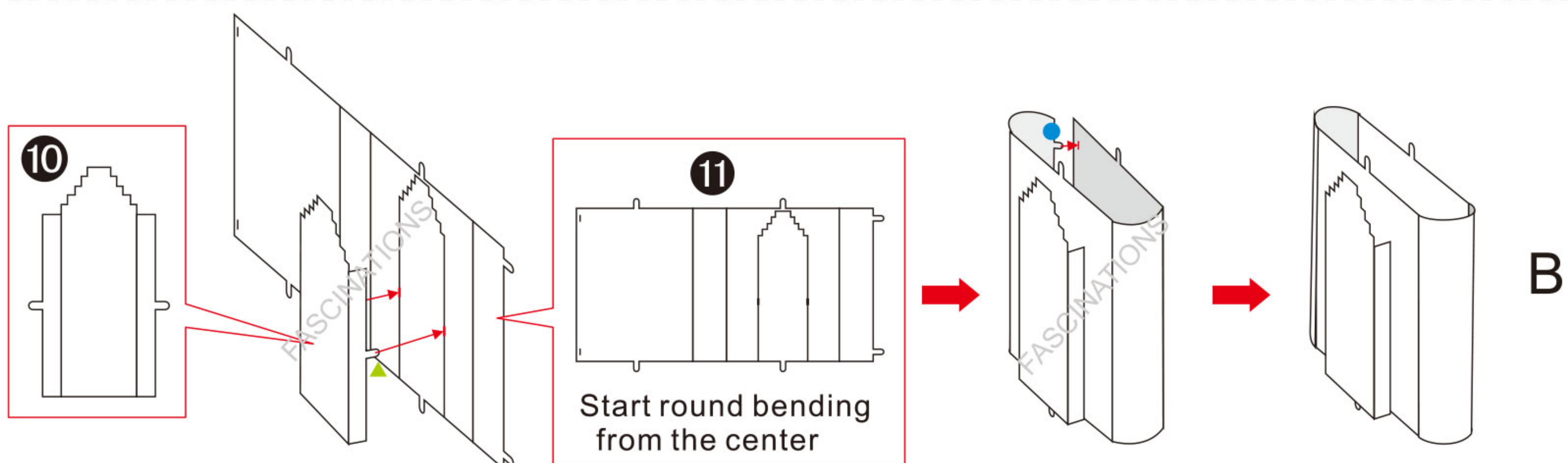

Start round bending from the center

B

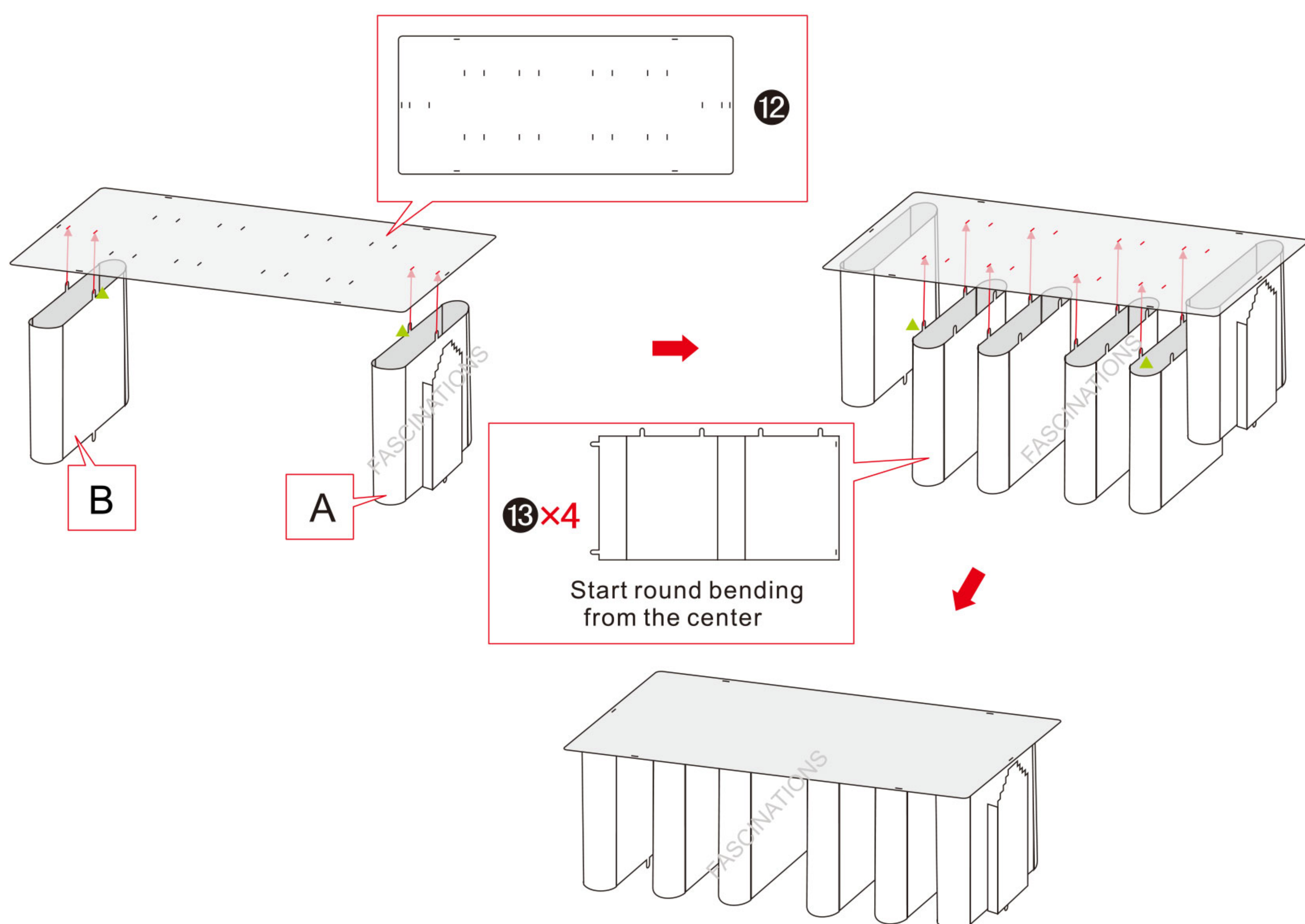

13x4

Start round bending from the center

