

T-34 Tank
Item No. MMS201



It is highly recommended that you visit www.metalearth.com/360/mms201 to see the completed model before assembling your own

Insertion tabs are inserted and then folded

Insertion holes

Fold lines can be seen as shown here

Legends:

- E Engraved side
- NE Non-engraved side
- Attention point
- Insert tab and bend 90 degrees
- ▲ Insert tab and twist 90 degrees

Assembly tip:
If needed, slightly twist tabs to hold parts together then untwist and bend them down for a nice finish

Recommended tools:

- Wire cutters: helpful for taking parts from the metal sheets.
- Tweezers or needle nose pliers: helpful for folding parts, bending and twisting tabs.

Metal sheets

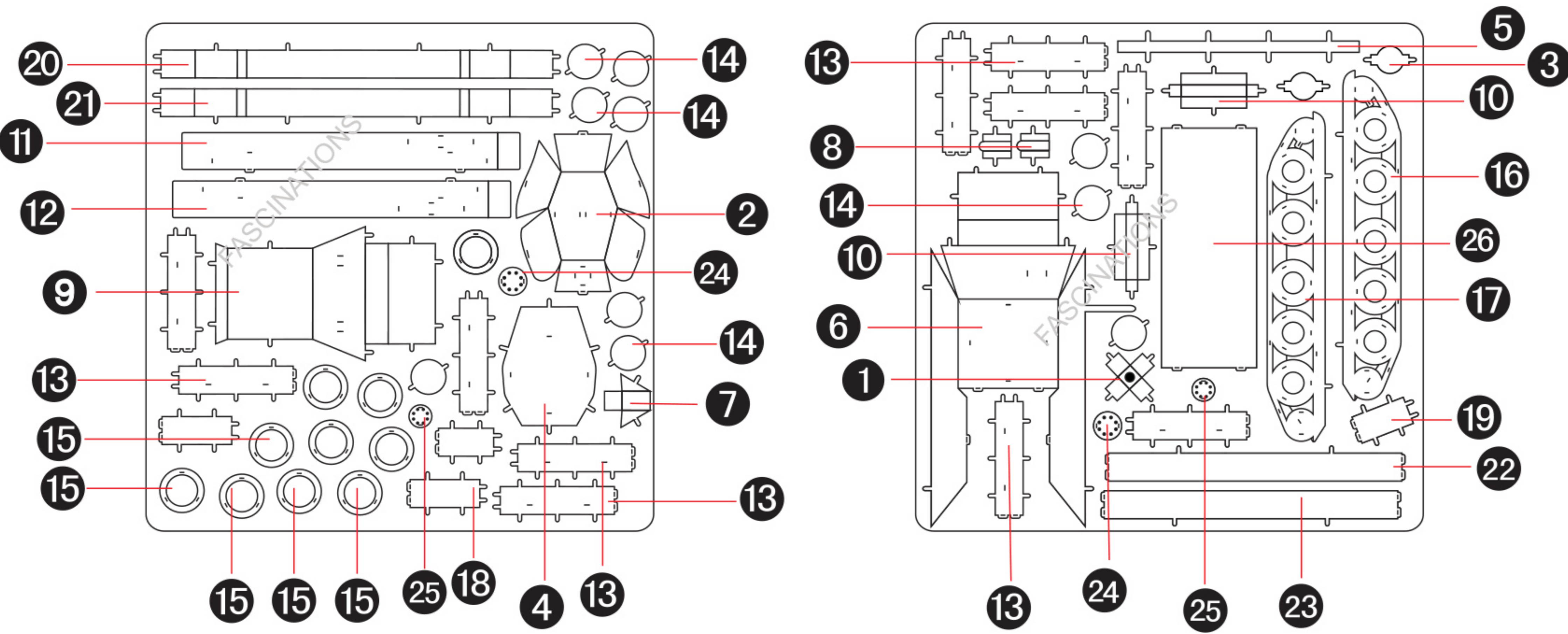

! In order to avoid possible injury from sharp edges, please carefully discard the metal sheet after parts have been removed

Assembly Flow Chart

