

Metal Earth

3D METAL MODEL KITS

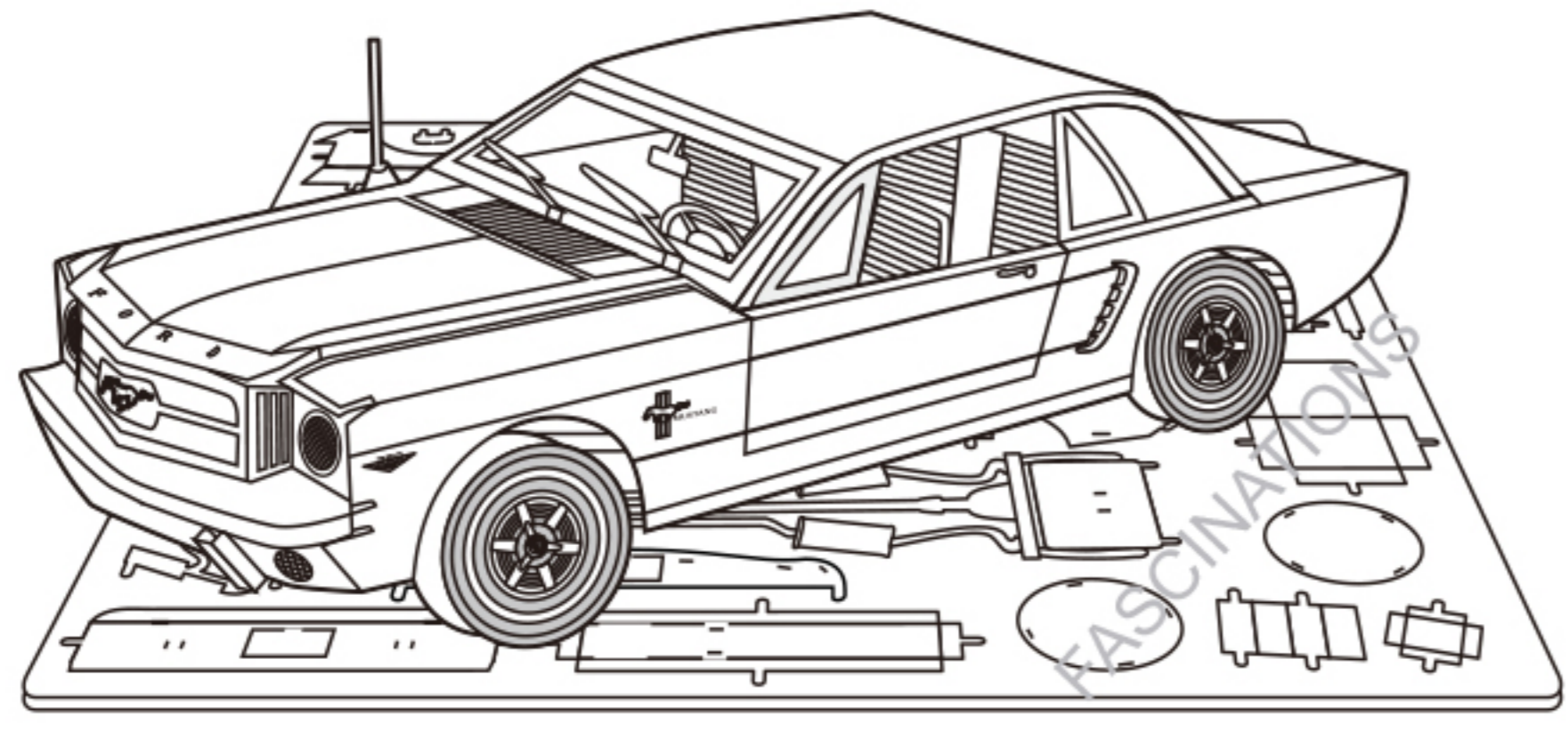

1965 Ford Mustang Coupe

Item No. MMS056



It is highly recommended that you visit www.metalearth.com/360/mms056 to see the completed model before assembling your own

Legends:

- E** Engraved side
- NE** Non-engraved side
- Hand icon** Attention point
- Blue circle** Insert tab and bend 90 degrees
- Yellow triangle** Insert tab and twist 90 degrees

Recommended tools:

- Wire cutters: helpful for taking parts from the metal sheets.
- Tweezers or needle nose pliers: helpful for folding parts, bending and twisting tabs.

Assembly tip:
If needed, slightly twist tabs to hold parts together then untwist and bend them down for a nice finish

Insertion tabs are inserted and then folded

Insertion holes

Fold lines can be seen as shown here

Metal sheets

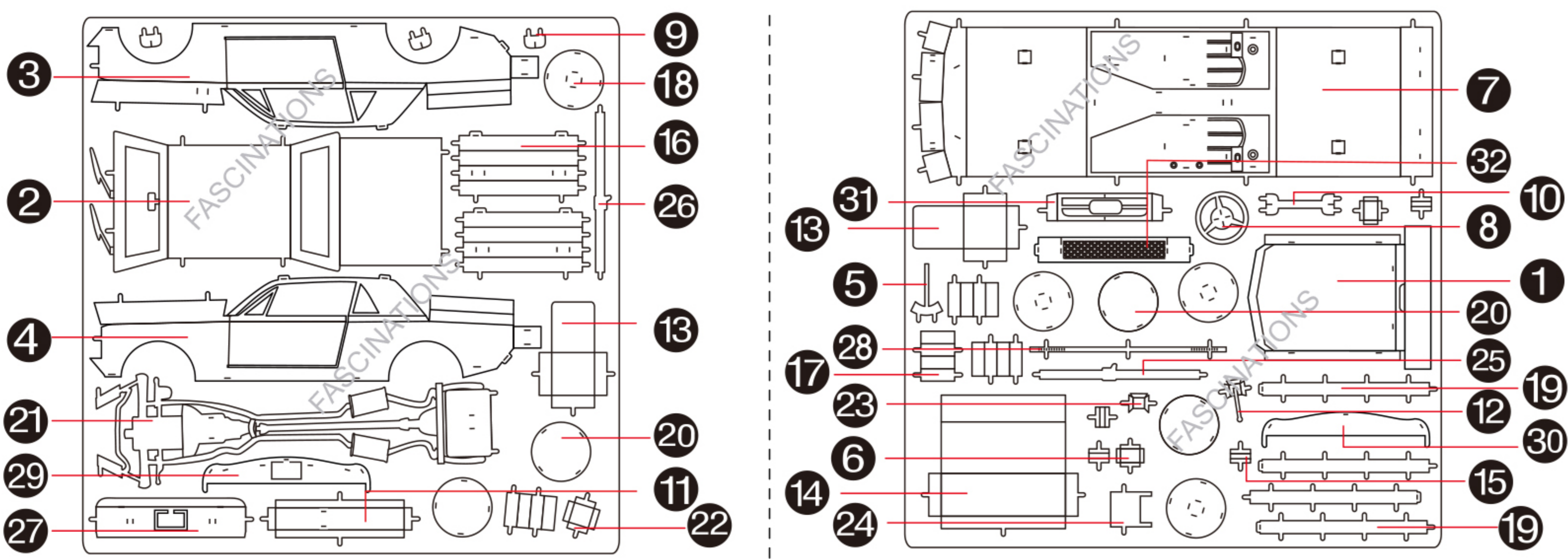

Warning: In order to avoid possible injury from sharp edges, please carefully discard the metal sheet after parts have been removed

Assembly Flow Chart

