

Stag Beetle

Item No. MMS071



It is highly recommended that you visit [www.metalearth.com/360/mms071](http://www.metalearth.com/360/mms071) to see the completed model before assembling your own

**Legends:**

- Engraved side
- Non-engraved side
- Attention point
- Insert tab and bend 90 degrees
- Insert tab and twist 90 degrees

**Recommended tools:**

-Wire cutters: helpful for taking parts from the metal sheets.

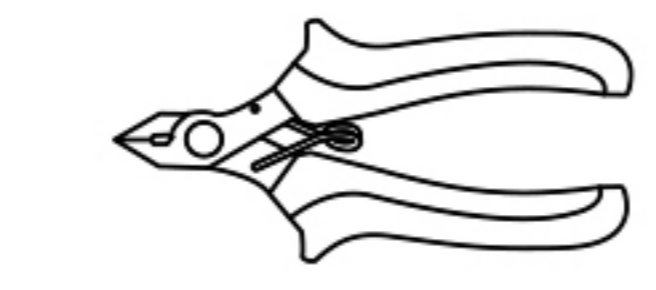

-Tweezers or needle nose pliers: helpful for folding parts, bending and twisting tabs.

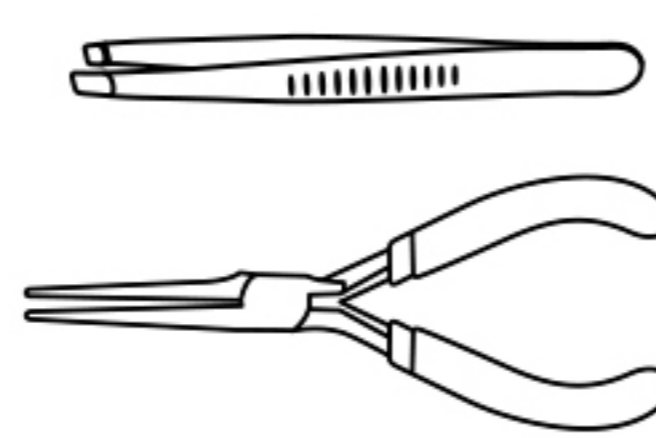

**Assembly tip:**

If needed, slightly twist tabs to hold parts together then untwist and bend them down for a nice finish

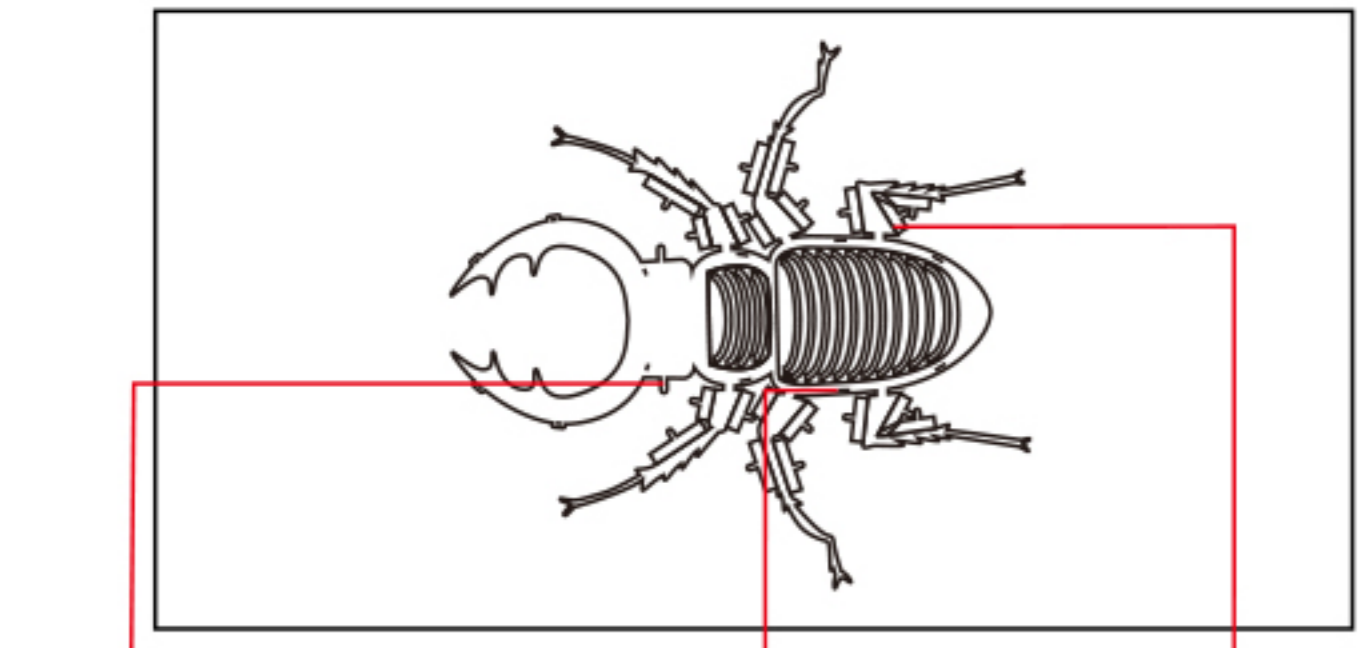

Insertion tabs are inserted and then folded

Insertion holes

Fold lines can be seen as shown here

**Metal sheet**

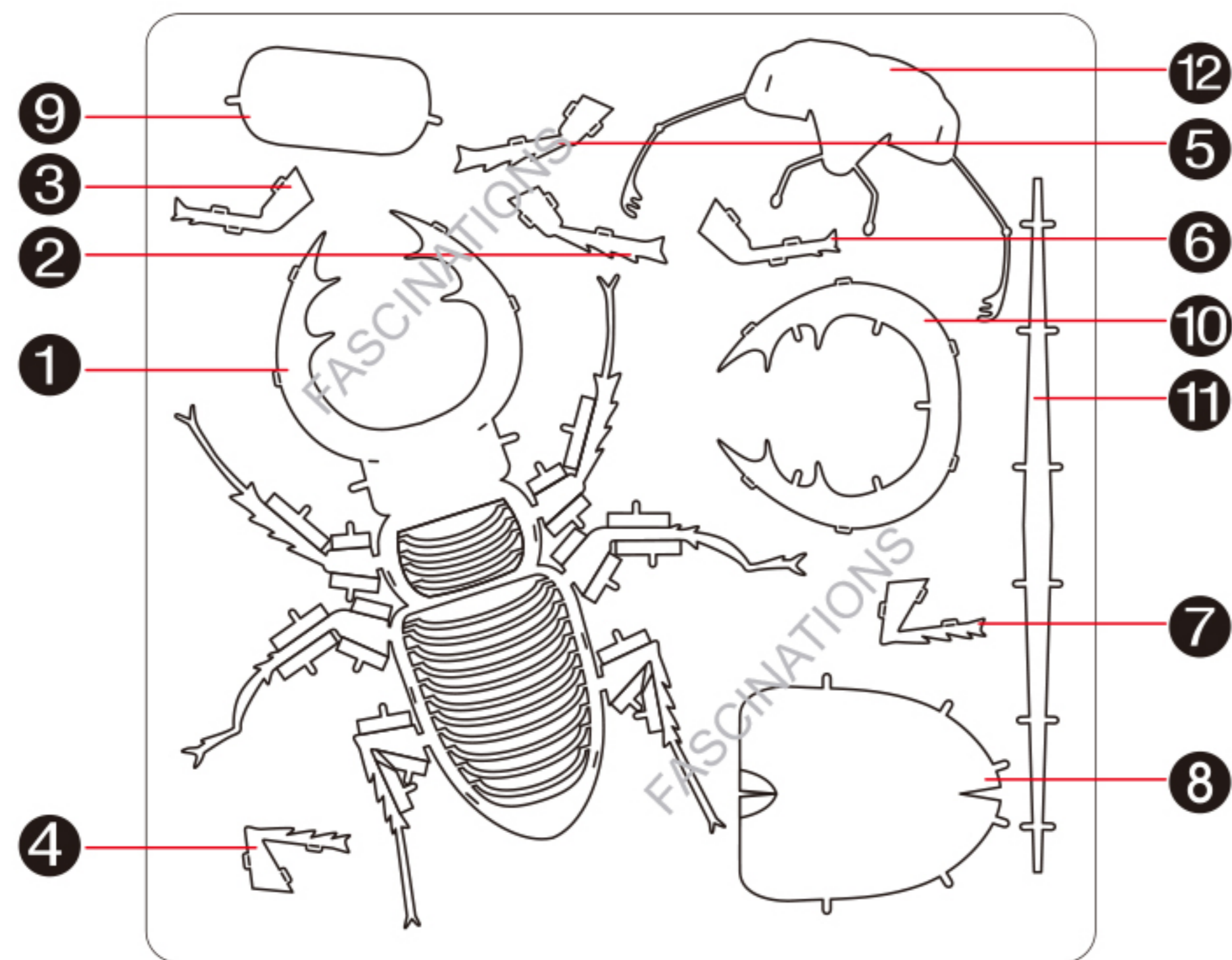

In order to avoid possible injury from sharp edges, please carefully discard the metal sheet after parts have been removed

**Assembly Flow Chart**

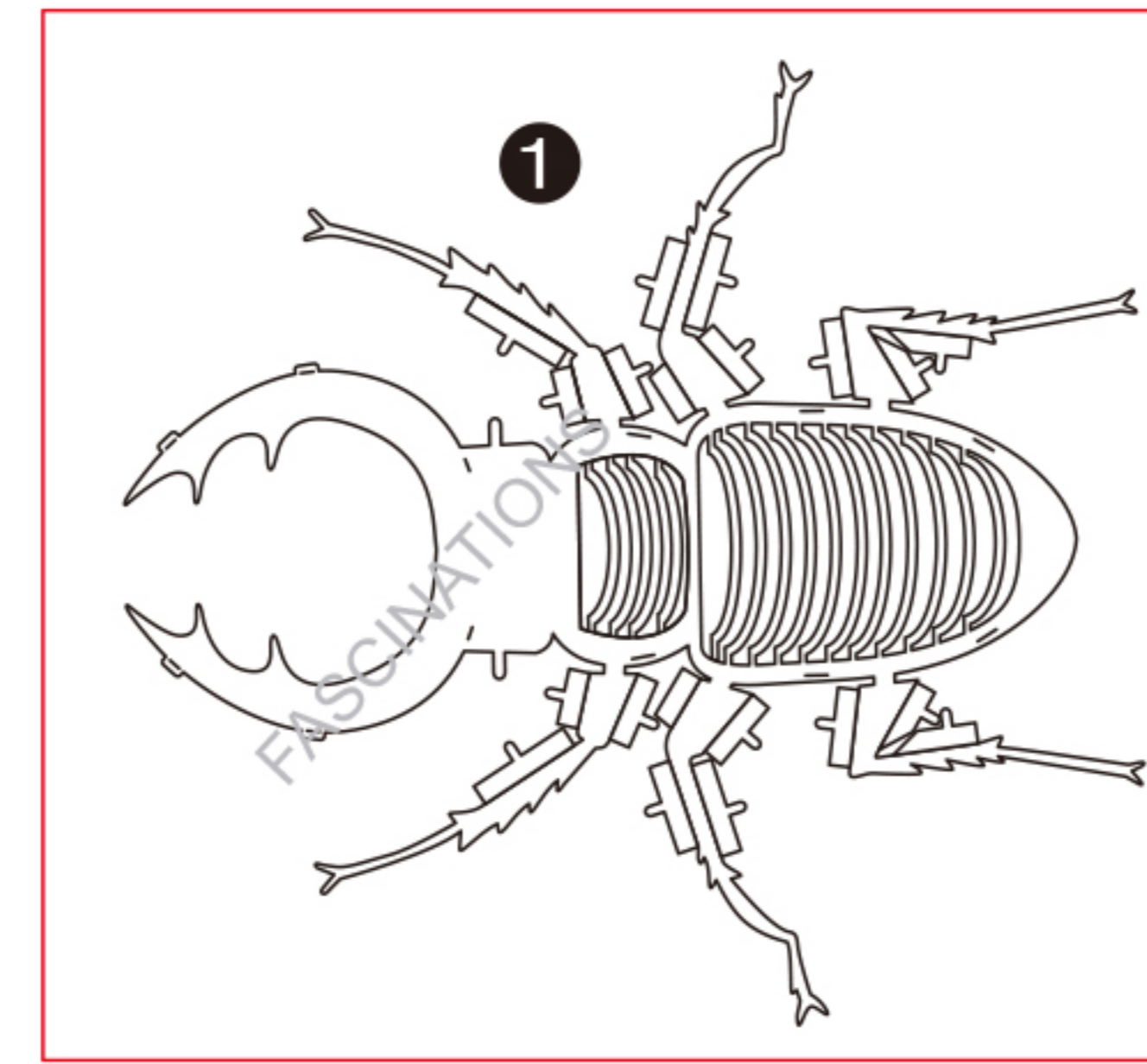

Engraved side faces up

Bending up by hand. Tip: doing this step before taking part #1 out of the metal sheet

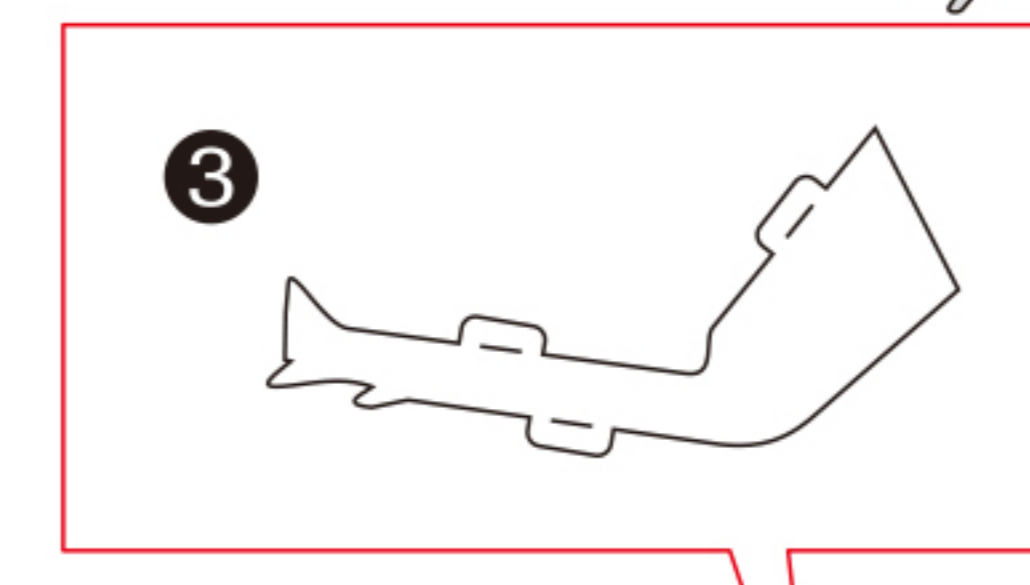
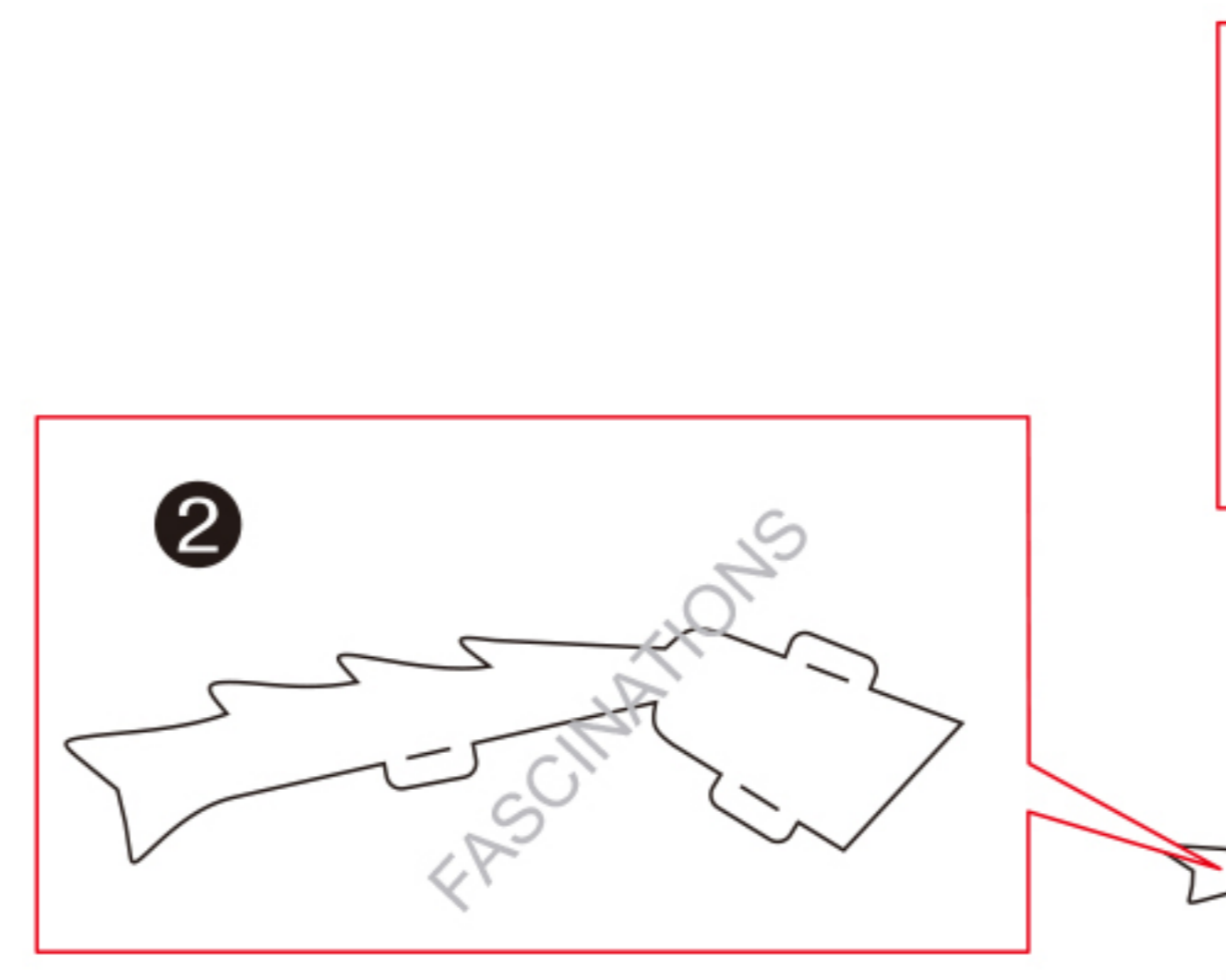
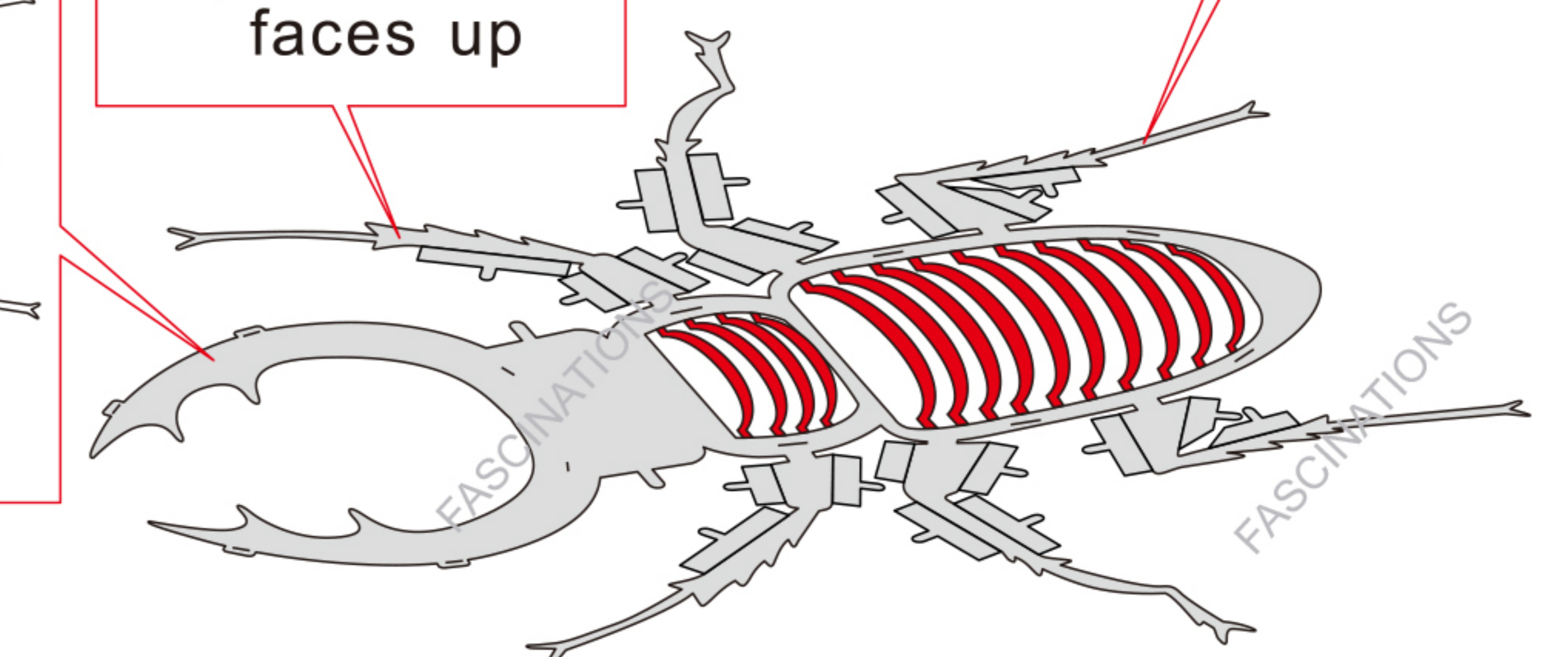

Engraved side faces up

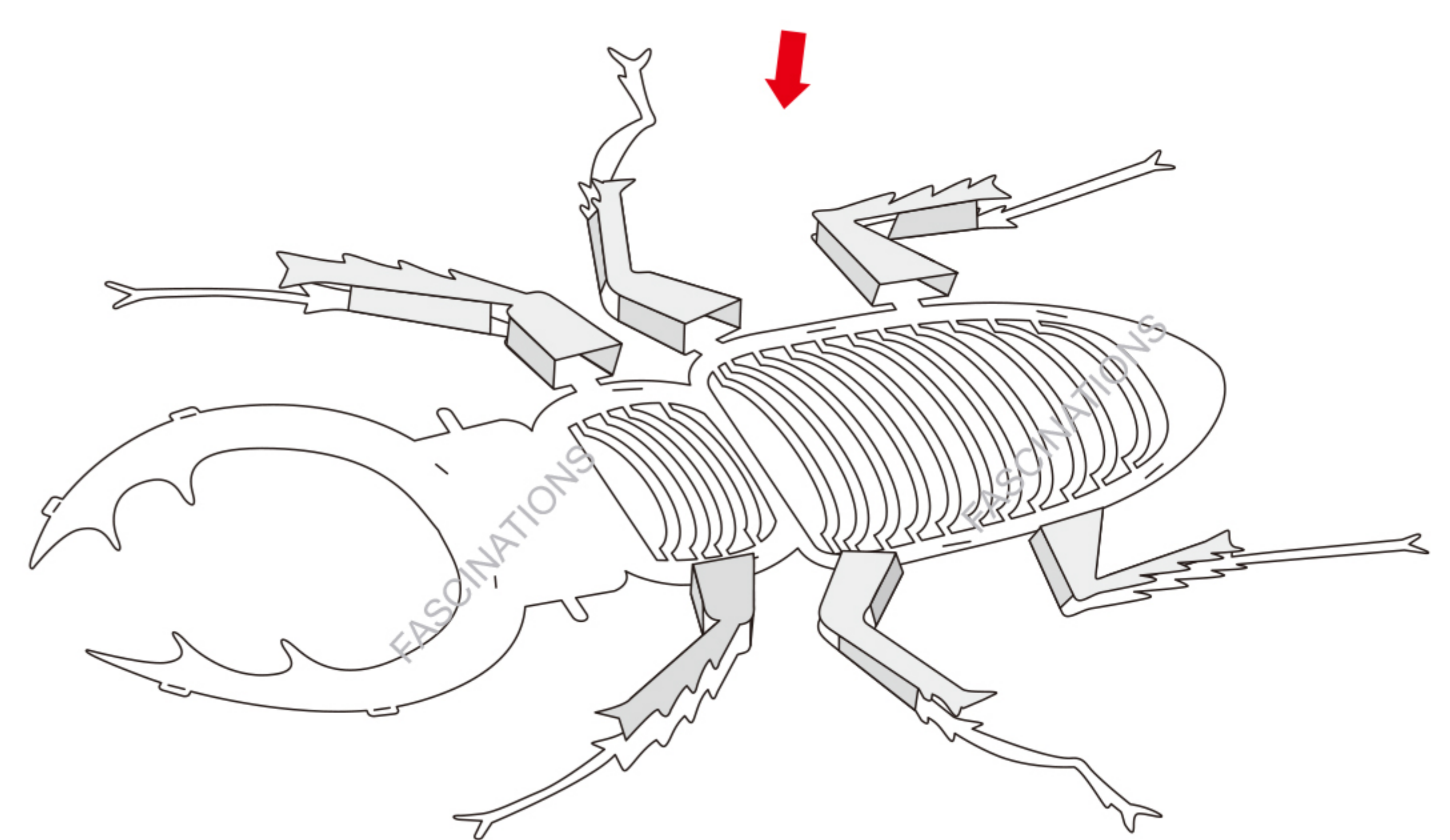
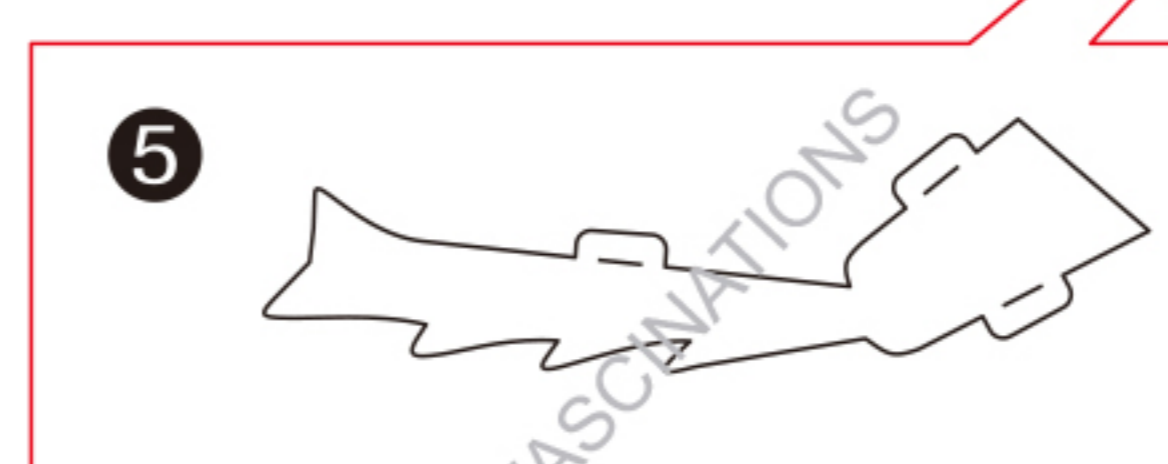
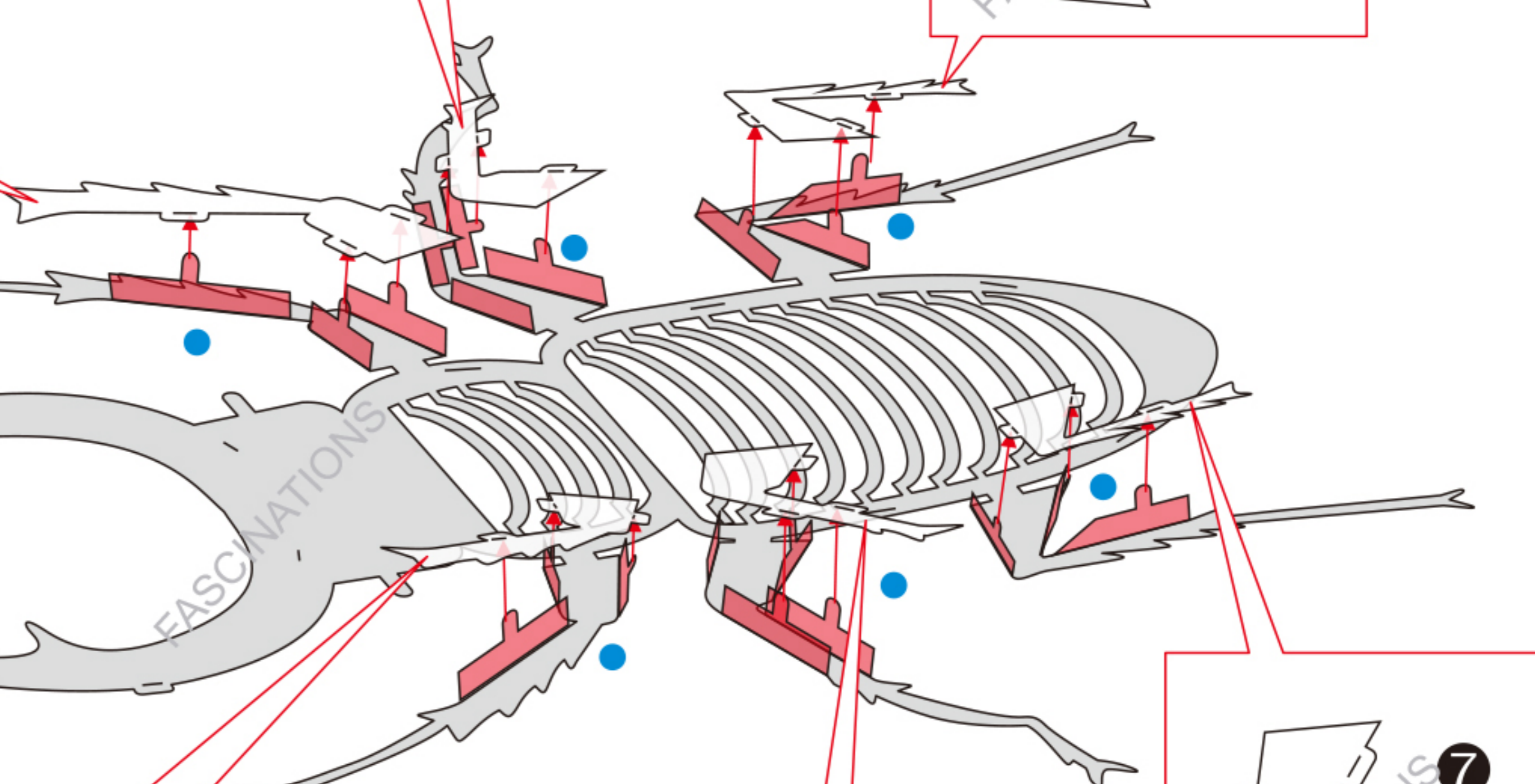
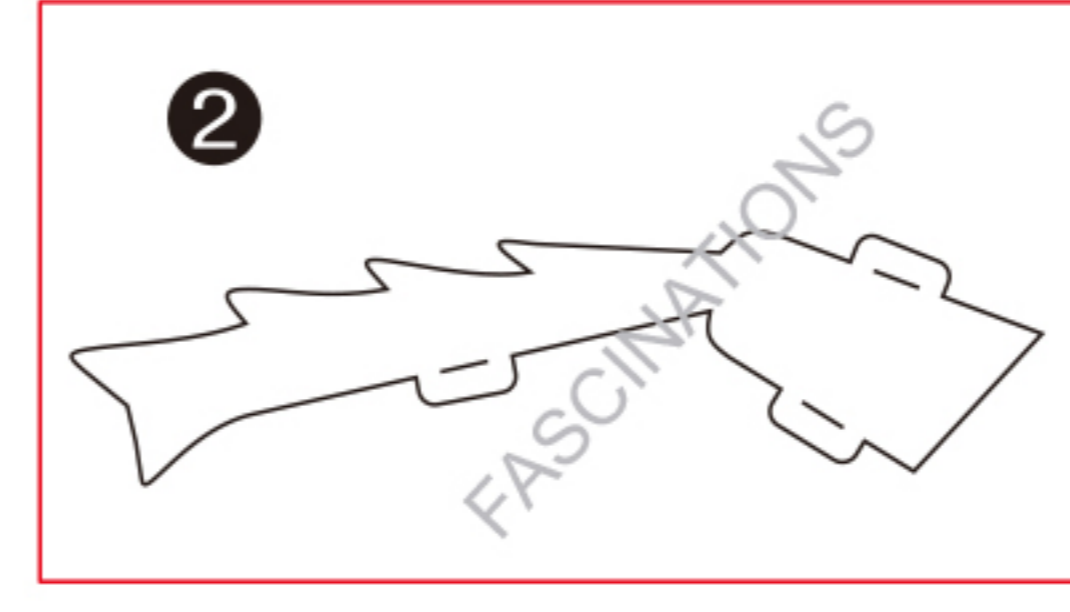

**Bending down by hand**

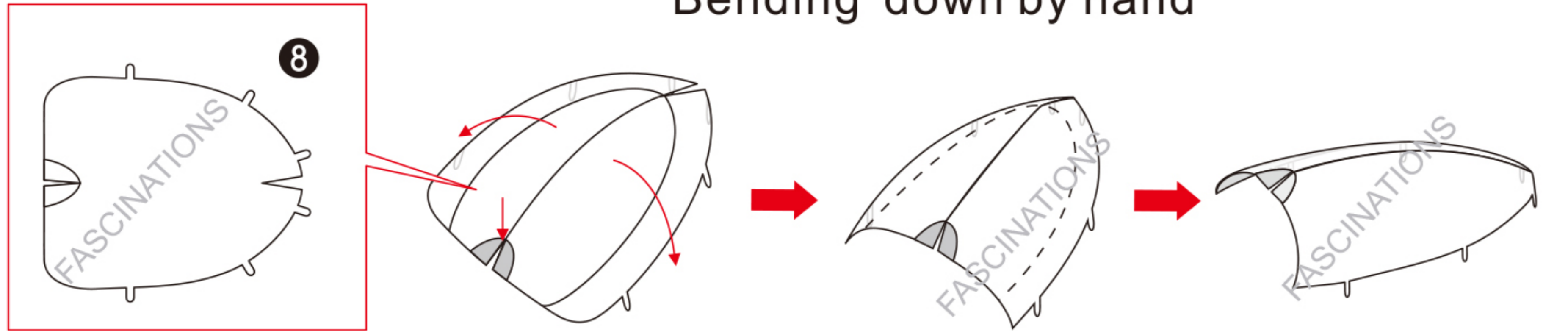

Engraved side faces down

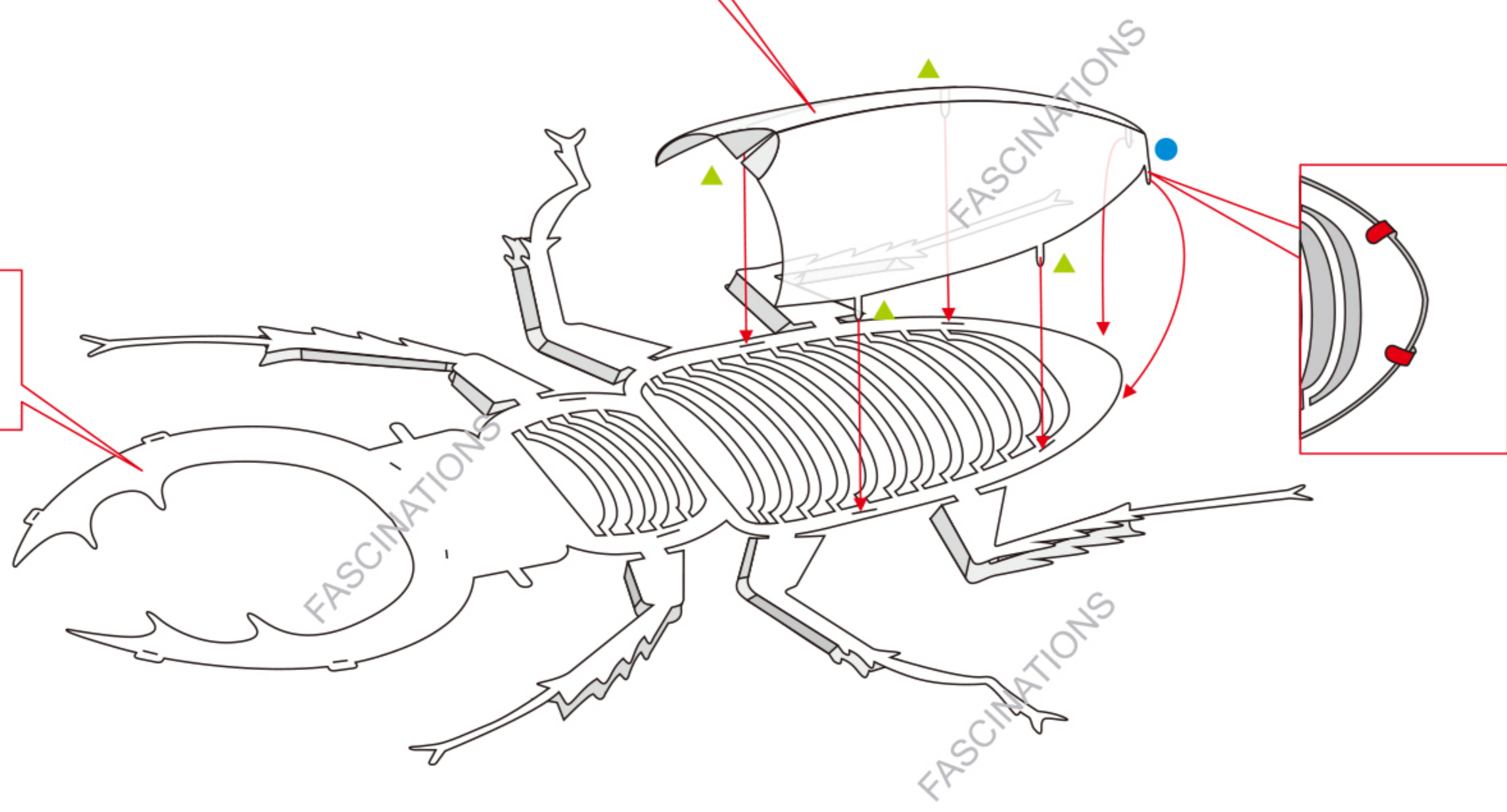

9

Bending by hand

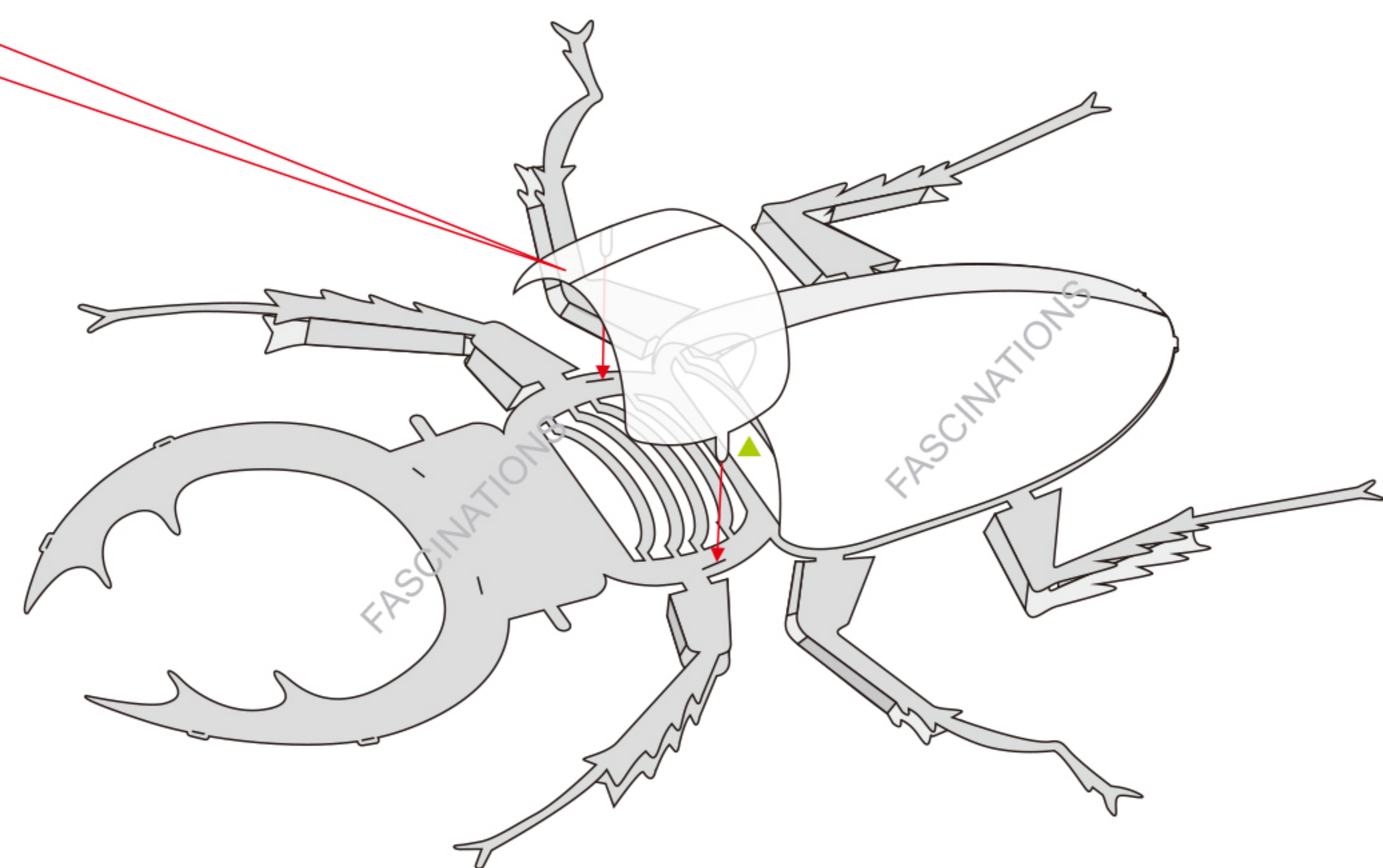
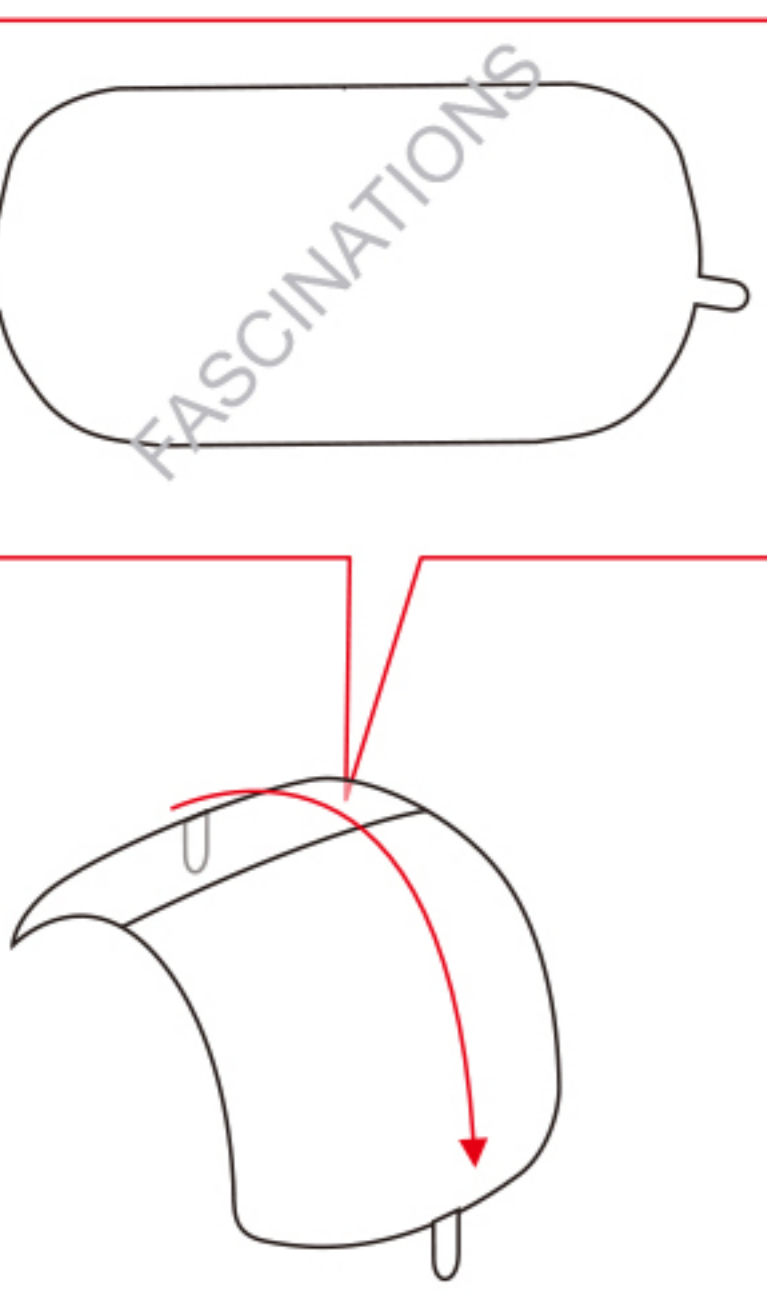

10

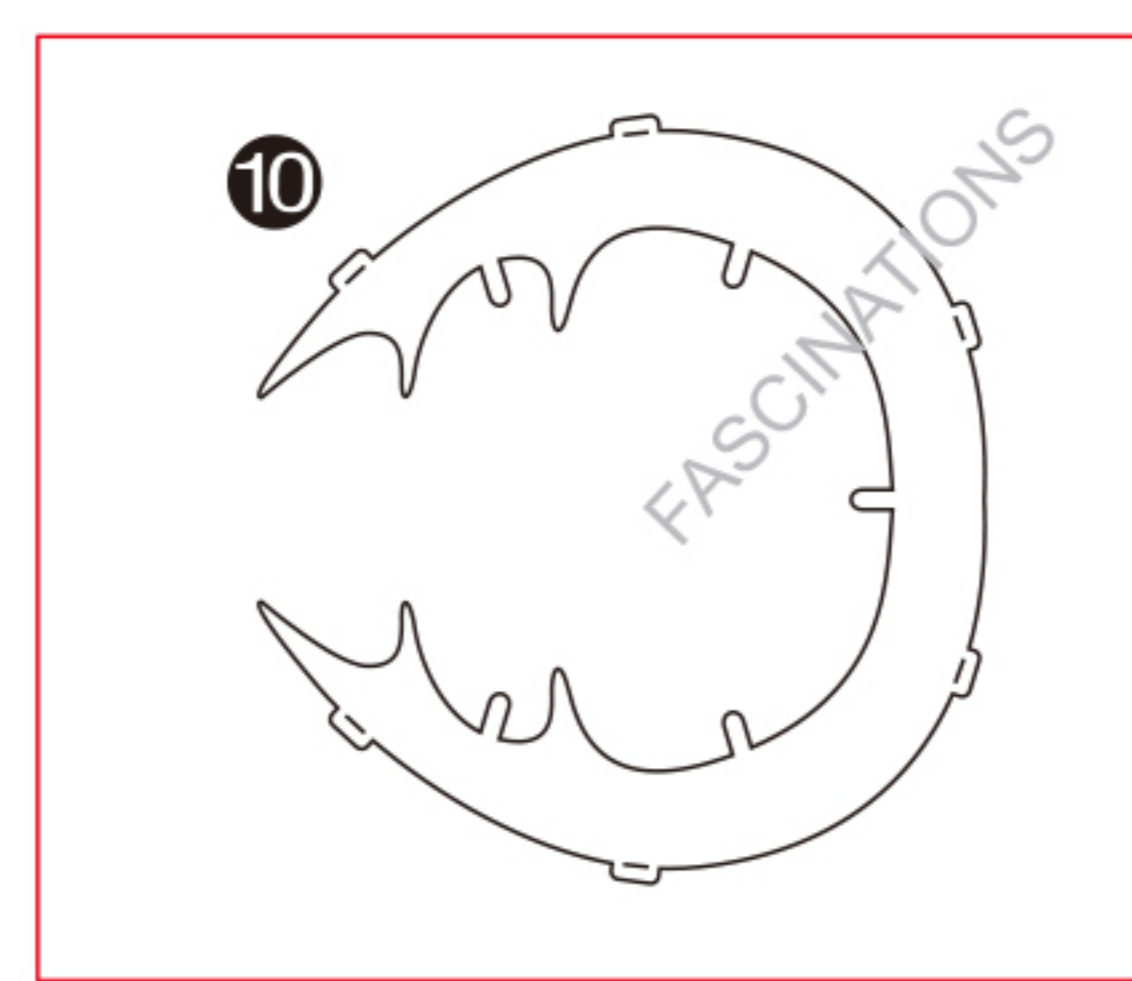

11

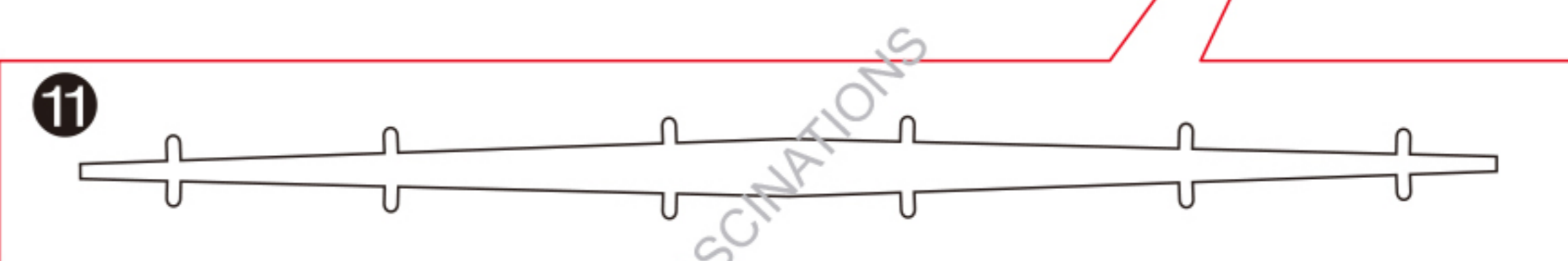

12

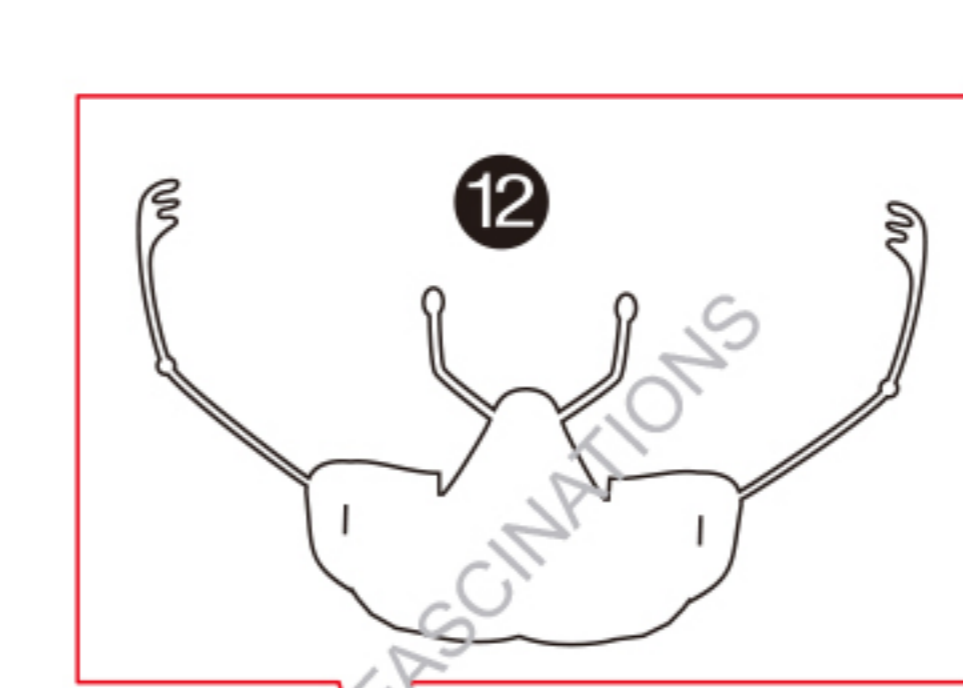

Bending by hand

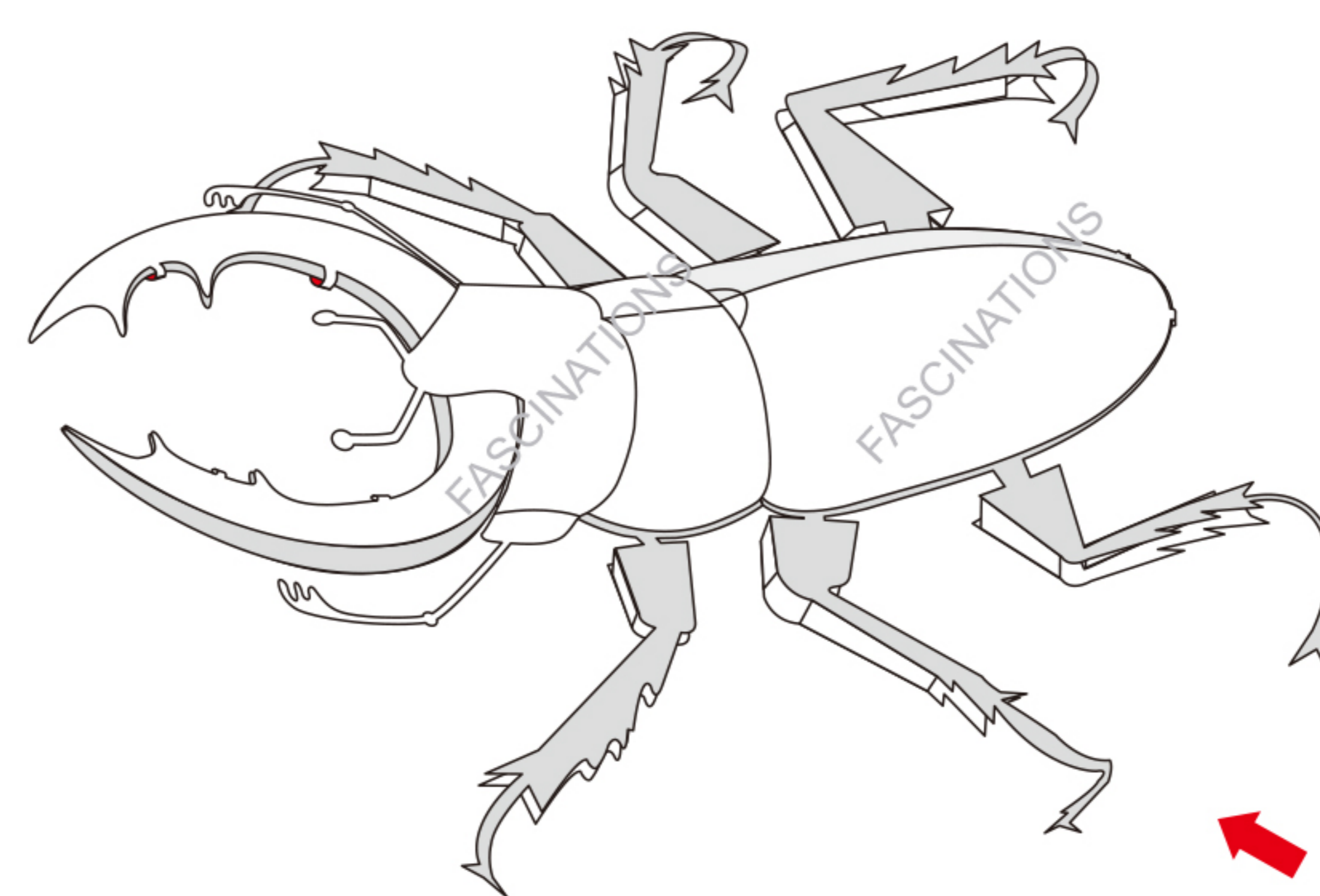

Bending by hand

