

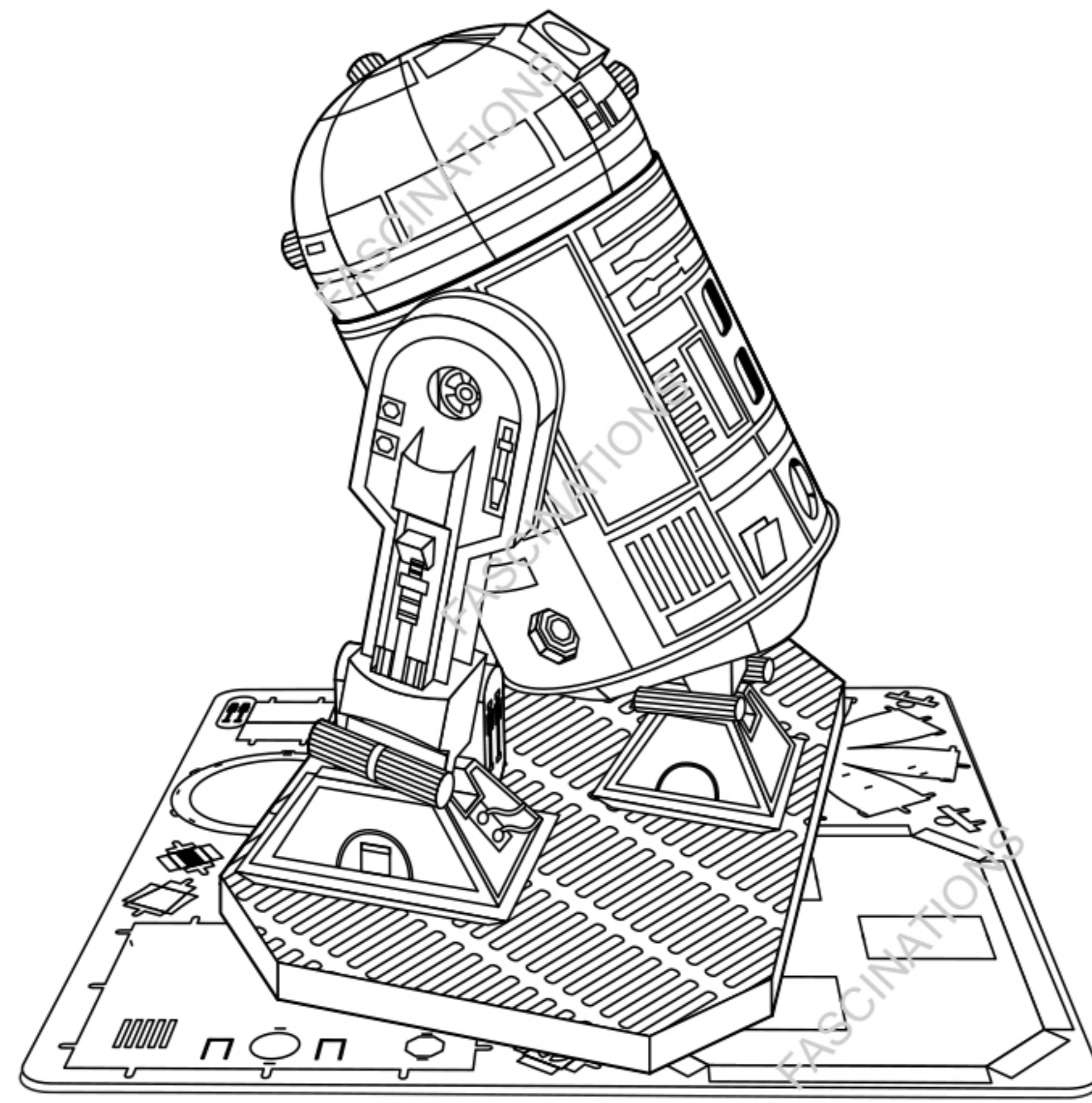

www.starwars.com
© & ™ Lucasfilm Ltd.



R2-D2™
Item No. MMS250

Metal Earth™
3D METAL MODEL KITS



It is highly recommended that you visit www.metalearth.com/360/mms250 to see the completed model before assembling your own

Legends:

- Engraved side
- Non-engraved side
- Attention point
- Insert tab and bend 90 degrees
- Insert tab and twist 90 degrees

Assembly tip:

If needed, slightly twist tabs to hold parts together then untwist and bend them down for a nice finish

Recommended tools:

-Wire cutters: helpful for taking parts from the metal sheets.



-Tweezers or needle nose pliers: helpful for folding parts, bending and twisting tabs.

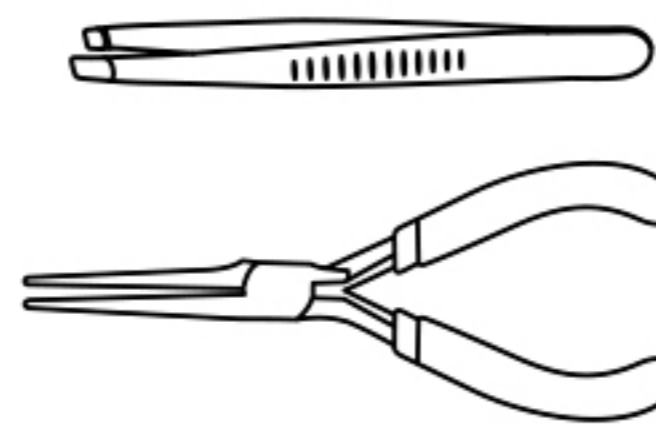

Metal sheets

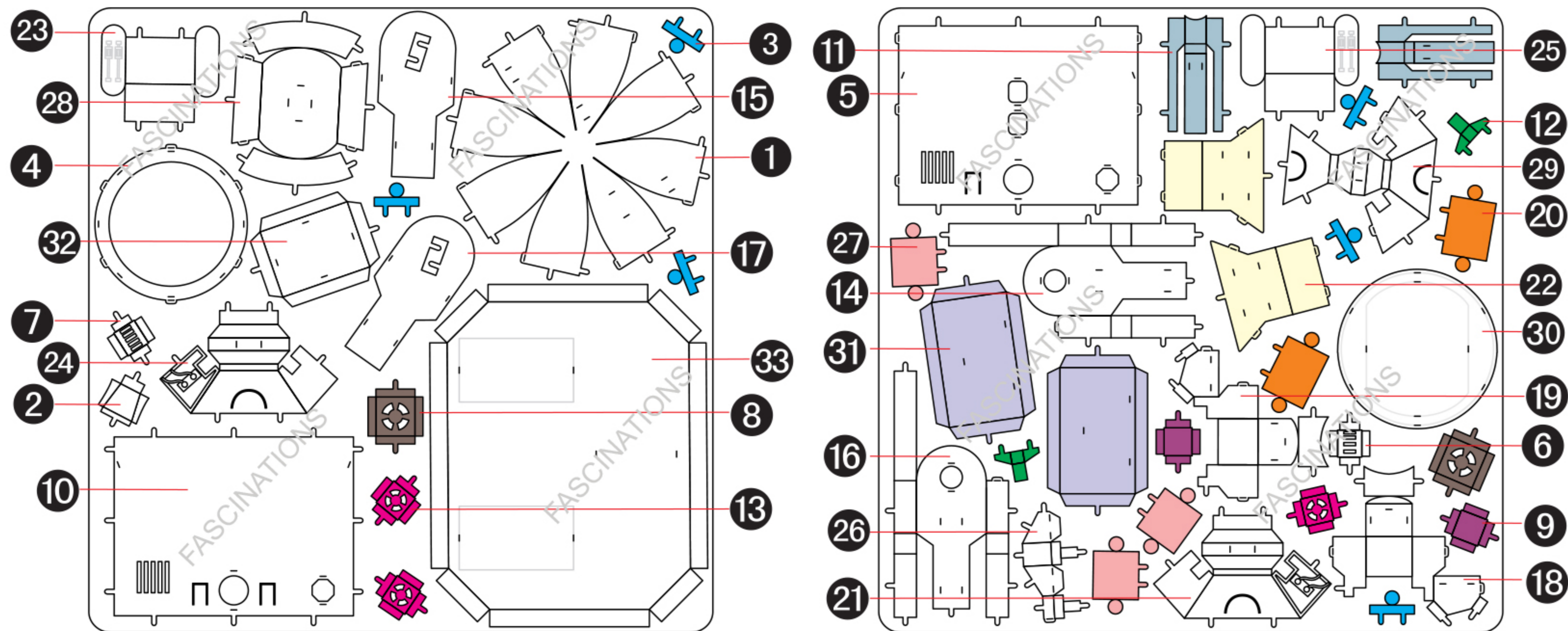

Notes:

In order to avoid possible injury from sharp edges, please carefully discard the metal sheet after parts have been removed.

This product is not a toy. Keep out of reach of children.

Assembly Flow Chart

