

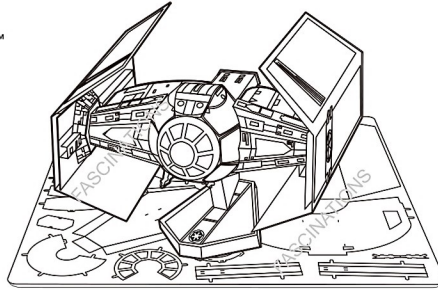

www.starwars.com
© &™ Lucasfilm Ltd.

Metal Earth

3D METAL MODEL KITS



Darth Vader's TIE Advanced X1™

Item No. MMS253



It is highly recommended that you visit www.metalearth.com/360/mms253 to see the completed model before assembling your own

Legends:

- E Engraved side
- NE Non-engraved side
- Attention point
- Insert tab and bend 90 degrees
- ▲ Insert tab and twist 90 degrees

Recommended tools:

- Wire cutters: helpful for taking parts from the metal sheets.
- Tweezers or needle nose pliers: helpful for folding parts, bending and twisting tabs.

Assembly tip:
If needed, slightly twist tabs to hold parts together then untwist and bend them down for a nice finish

Metal sheets

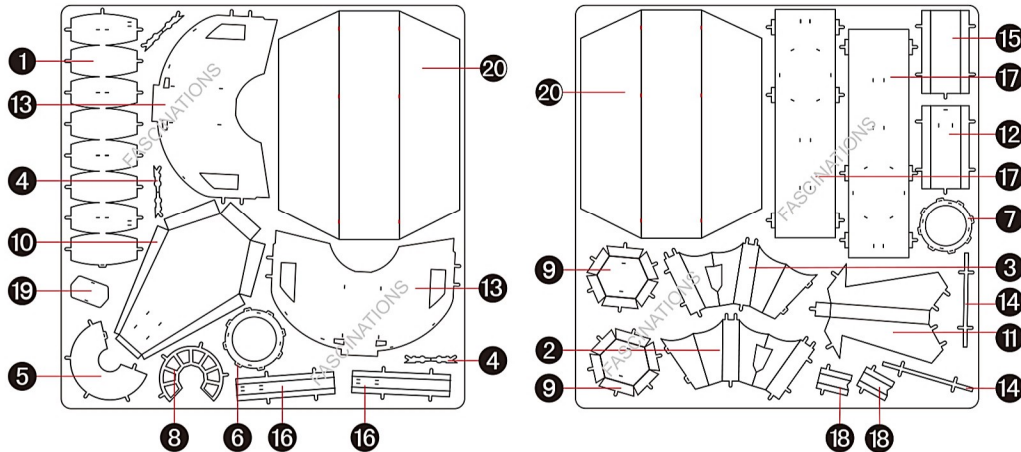

Notes:

In order to avoid possible injury from sharp edges, please carefully discard the metal sheet after parts have been removed.

This product is not a toy. Keep out of reach of children.

Assembly Flow Chart

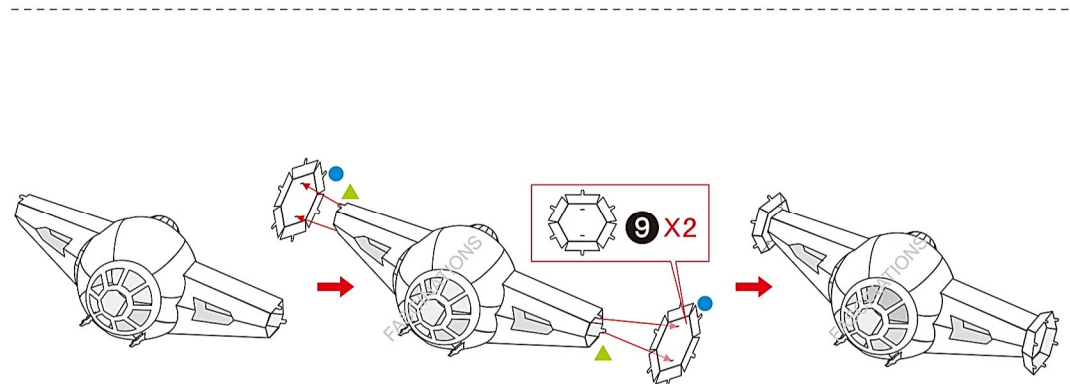
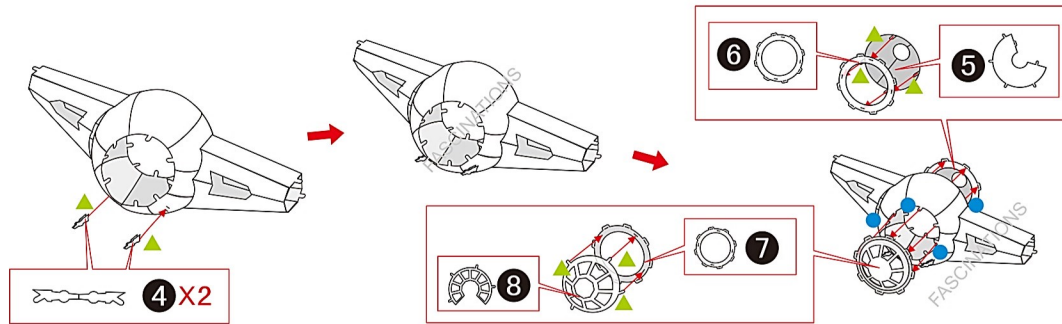
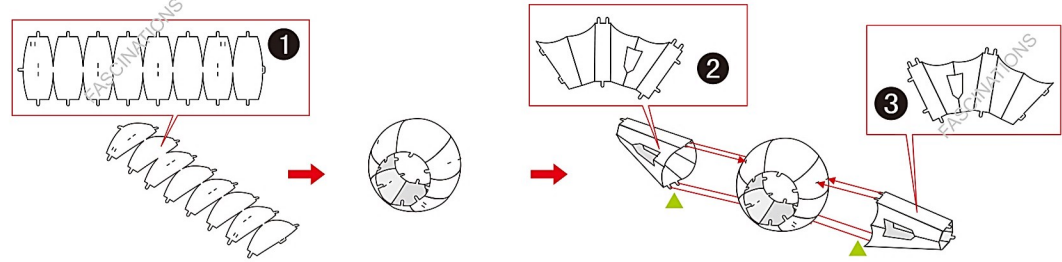

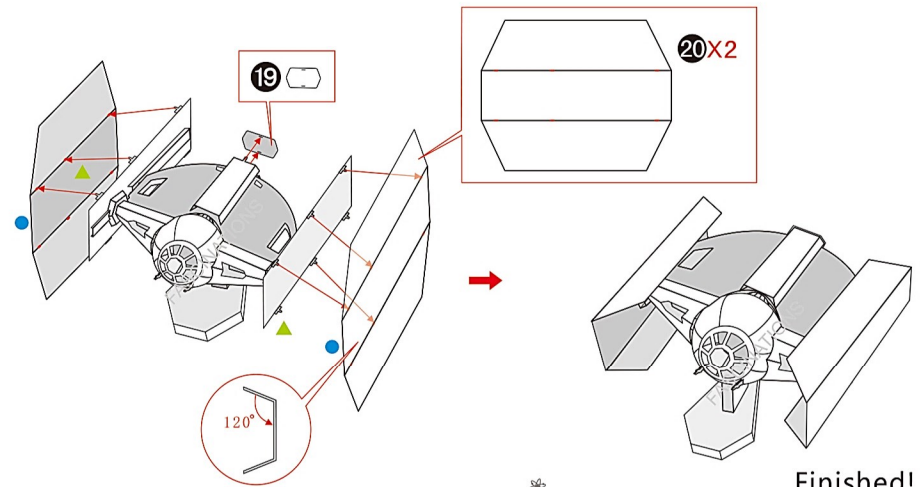
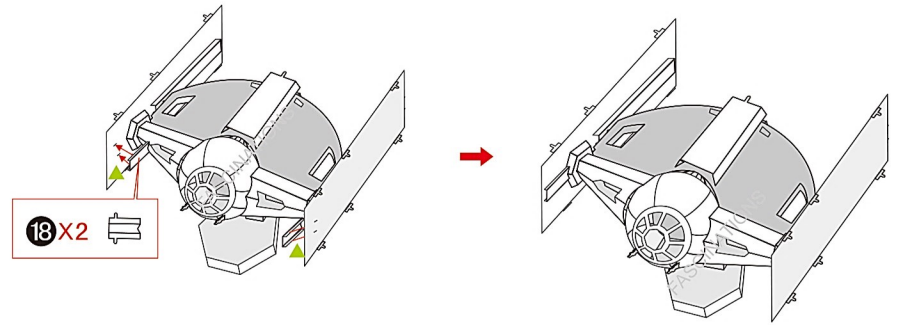
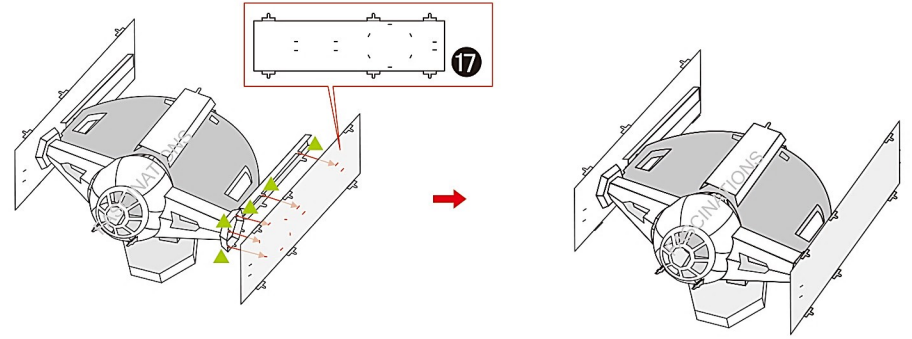
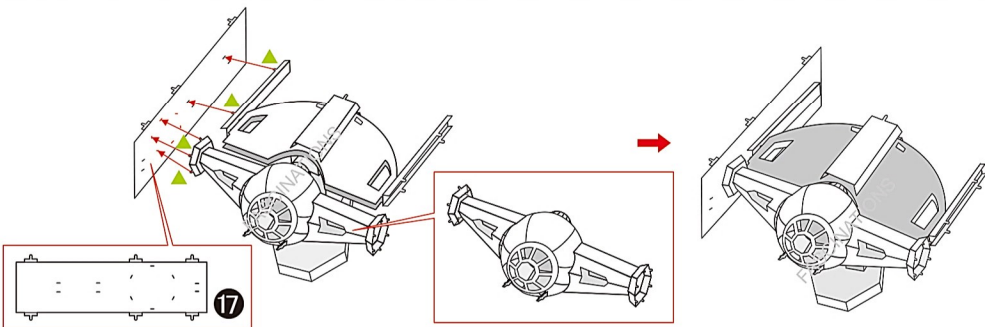
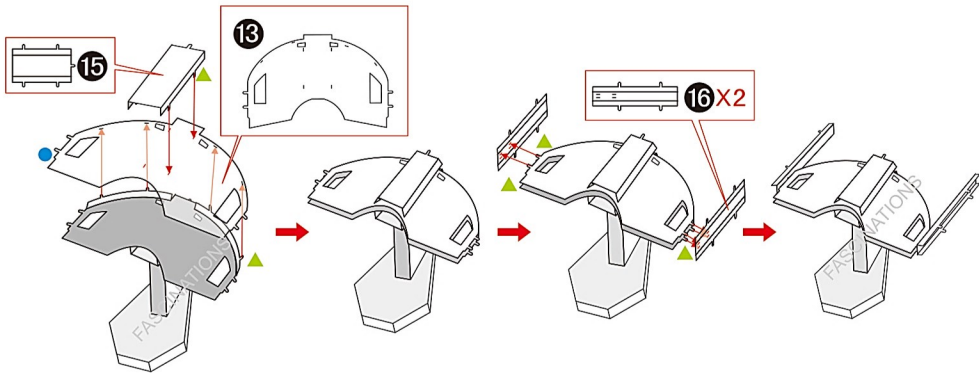
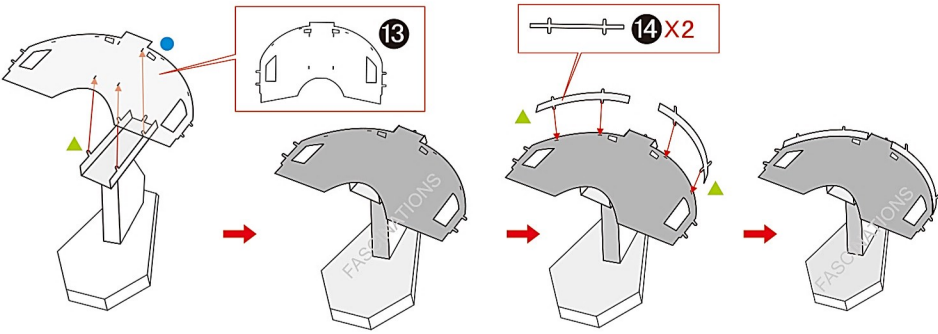
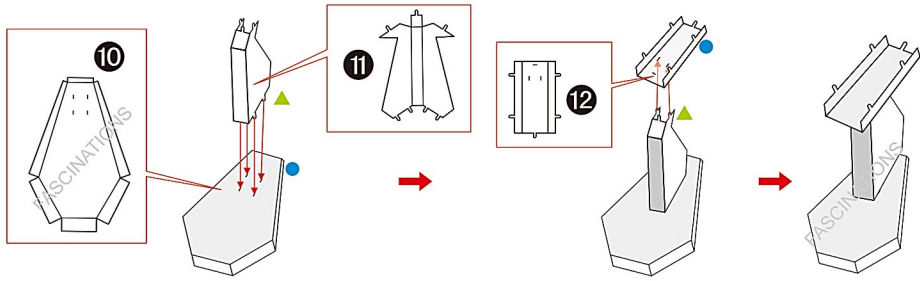

Finished!

starwars.com

© 2013 Lucasfilm Ltd. & TM. All rights reserved.

Fascinations®
© 2017 Fascinations Seattle, WA
www.metalearth.com