

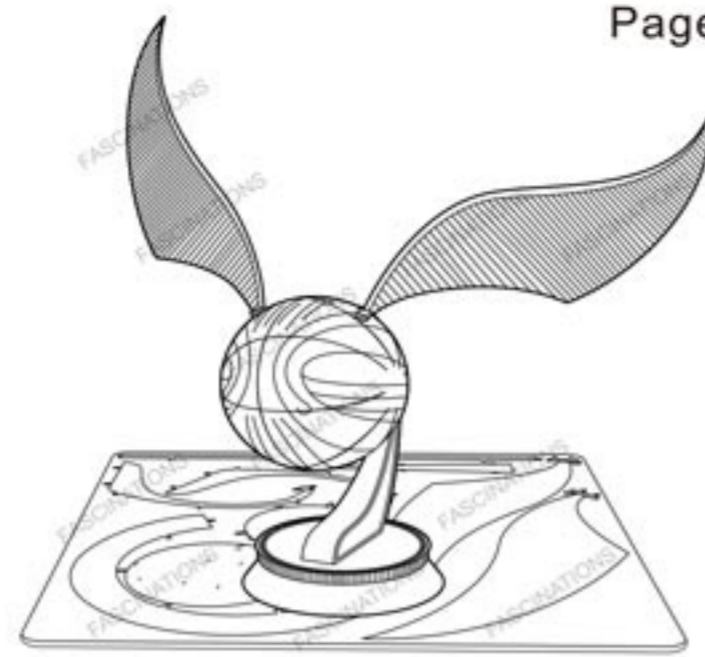

# METAL EARTH<sup>®</sup> 3D METAL MODEL KITS



It is highly recommended that you visit [www.fascinations.com/360/mms442](http://www.fascinations.com/360/mms442) to see the completed model before assembling your own



## GOLDEN SNITCH

Item No. MMS442

**To create the best connections**

- Insert tab and bend 90 degrees for most visible areas
- Insert tab and twist 90 degrees is best in some areas to ensure a tight connection

Needle nose pliers are helpful for assembly

Legends:

- Engraved side
- Non-engraved side
- Attention point

Insertion tabs are inserted and then folded

Fold lines can be seen as shown here

Pull and Screw metal tab 90° to tighten

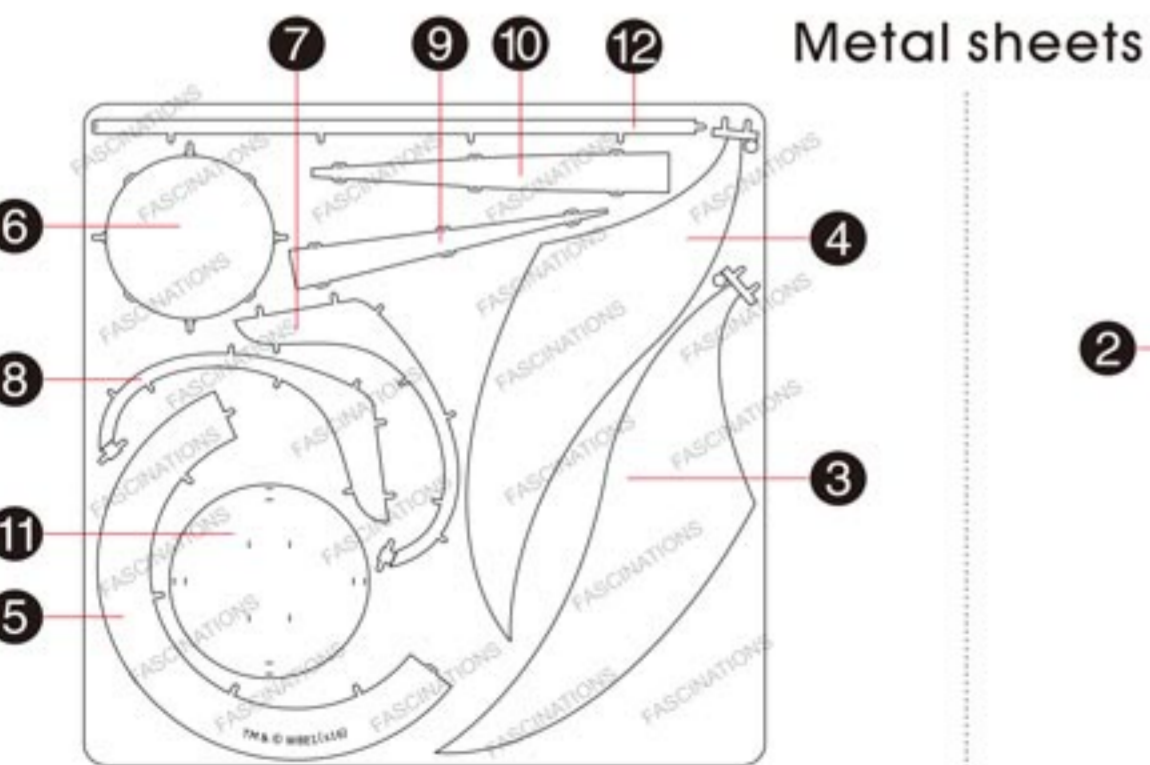

In order to avoid possible injury from sharp edges, please carefully discard the metal sheet after parts have been removed

### Assembly Flow Chart

